

Q. No. 1 – 25 Carry One Mark Each

1. Consider an undirected random graph of eight vertices. The probability that there is an edge between a pair of vertices is $\frac{1}{2}$. What is the expected number of unordered cycles of length three?
 (A) $\frac{1}{8}$ (B) 1 (C) 7 (D) 8

Answer:-(C)

Exp:- $P(\text{edge}) = \frac{1}{2}$

Number of ways we can choose the vertices out of 8 is 8C_3
 (Three edges in each cycle)

Expected number of unordered cycles of length 3 = ${}^8C_3 \times \frac{1}{2} \times \frac{1}{2} \times \frac{1}{2} = 7$

2. Which of the following statements is/are TRUE for undirected graphs?
 P: Number of odd degree vertices is even.
 Q: Sum of degrees of all vertices is even.
 (A) P only (B) Q only
 (C) Both P and Q (D) Neither P nor Q

Answer:- (C)

Exp:- Q: Sum of degrees of all vertices = $2 \times (\text{number of edges})$

3. Function f is known at the following points:

x	0	0.3	0.6	0.9	1.2	1.5	1.8	2.1	2.4	2.7	3.0
f(x)	0	0.09	0.36	0.81	1.44	2.25	3.24	4.41	5.76	7.29	9.00

The value of $\int_0^3 f(x) dx$

- (A) 8.983 (B) 9.003 (C) 9.017 (D) 9.045
 computed using the trapezoidal rule is

Answer:- (D)

Exp:- $\int_0^3 f(x) dx = \frac{h}{2} [f(x_0) + f(x_{10}) + 2(f(x_1) + f(x_2) + \dots + f(x_9))]$

$= \frac{0.3}{2} [9.00 + 2(2.25 + 5.76)] = 9.045$

4. Which one of the following functions is continuous at $x = 3$?

(A) $f(x) = \begin{cases} 2, & \text{if } x = 3 \\ x-1, & \text{if } x > 3 \\ \frac{x+3}{3}, & \text{if } x < 3 \end{cases}$

(B) $f(x) = \begin{cases} 4, & \text{if } x = 3 \\ 8-x, & \text{if } x \neq 3 \end{cases}$

(C) $f(x) = \begin{cases} \frac{x+3}{4}, & \text{if } x \leq 3 \\ x-3, & \text{if } x > 3 \end{cases}$

(D) $f(x) = \frac{1}{x^3 - 27}$ if $x \neq 3$

Answer:-(A)

Exp:- $\lim_{x \rightarrow 3^+} f(x) = \lim_{x \rightarrow 3^+} (x-1) = 2 = f(3)$

$\lim_{x \rightarrow 3^-} f(x) = \lim_{x \rightarrow 3^-} \frac{x+3}{3} = 2 = f(3)$

$\therefore f(x)$ is continuous at $x = 3$

5. Which one of the following expressions does NOT represent exclusive NOR of x and y ?

- (A) $xy + x'y'$ (B) $x \oplus y'$ (C) $x' \oplus y$ (D) $x' \oplus y'$

Answer: -(D)

Exp:- (A) $x \oplus y = xy + x'y'$

(B) $x \oplus y = xy + x'y = xy + x'y = x'y$

$x'y = x'y = x'y + x'y = x'y$

(C) $x \oplus y = (x'y + xy')$

(D) $x \oplus y = (x'y + x'y')$

6. In a k -way set associative cache, the cache is divided into v sets, each of which consists of k lines. The lines of a set are placed in sequence one after another. The lines in set s are sequenced before the lines in set $(s+1)$. The main memory blocks are numbered 0 onwards. The main memory block numbered j must be mapped to any one of the cache lines from

- (A) $(j \bmod v) * k$ to $(j \bmod v) * k + (k-1)$
- (B) $(j \bmod v) * k$ to $(j \bmod v) * k + (v-1)$
- (C) $(j \bmod k)$ to $(j \bmod k) + (k-1)$
- (D) $(j \bmod k) * v$ to $(j \bmod k) * v + (v-1)$

Answer: -(A)

Exp:- Position of main memory block in the cache (set) = (main memory block number) MOD (number of sets in the cache).

As the lines in the set are placed in sequence, we can have the lines from 0 to $(K - 1)$ in each set.

Number of sets = v , main memory block number = j

First line of cache = $(j \bmod v) * k$; last line of cache = $(j \bmod v) * k + (k - 1)$

7. What is the time complexity of Bellman-Ford single-source shortest path algorithm on a complete graph of n vertices?

- (A) $\Theta(n^2)$ (B) $\Theta(n^2 \log n)$ (C) $\Theta(n^3)$ (D) $\Theta(n^3 \log n)$

Answer: (C)

Exp:- Bellman-ford time complexity: $\Theta(|V| \times |E|)$
 For complete graph: $|E| = \frac{n(n-1)}{2}$
 $|V| = n$
 $\therefore \Theta\left(n \times \frac{n(n-1)}{2}\right) = \Theta(n^3)$

8. Which of the following statements are TRUE?

- (1) The problem of determining whether there exists a cycle in an undirected graph is in P.
 - (2) The problem of determining whether there exists a cycle in an undirected graph is in NP.
 - (3) If a problem A is NP-Complete, there exists a non-deterministic polynomial time algorithm to solve A.
- (A) 1,2 and 3 (B) 1 and 2 only (C) 2 and 3 only (D) 1 and 3 only

Answer: (A)

Exp:- 1. Cycle detection using DFS: $O(V+E) = O(V^2)$ and it is polynomial problem

(
 2. Every P-problem is NP since $P \subseteq NP$
 3. NP-complete \subseteq NP

Hence, NP-complete can be solved in non-deterministic polynomial time

9. Which of the following statements is/are FALSE?

- (1) For every non-deterministic Turing machine, there exists an equivalent deterministic Turing machine.
 - (2) Turing recognizable languages are closed under union and complementation.
 - (3) Turing decidable languages are closed under intersection and complementation
 - (4) Turing recognizable languages are closed under union and intersection.
- (A) 1 and 4 only (B) 1 and 3 only (C) 2 only (D) 3 only

Answer: (C)

Exp:- (1) $NTM \cong DTM$

(2) RELs are closed under union & but not complementation

(3) Turing decidable languages are recursive and recursive languages are closed under intersection and complementation

(4) RELs are closed under union & intersection but not under complementation

10. Three concurrent processes X, Y, and Z execute three different code segments that access and update certain shared variables. Process X executes the P operation (i.e., wait) on semaphores a, b and c; process Y executes the P operation on semaphores b, c and d; process Z executes the P operation on semaphores c, d, and a before entering the respective code segments. After completing the execution of its code segment, each process invokes the V operation (i.e., signal) on its three semaphores. All semaphores are binary semaphores initialized to one. Which one of the following represents a deadlock-free order of invoking the P operations by the processes?

- (A) X: P(a) P(b) P(c) Y: P(b) P(c) P(d) Z: P(c) P(d) P(a)
 (B) X: P(b) P(a) P(c) Y: P(b) P(c) P(d) Z: P(a) P(c) P(d)
 (C) X: P(b) P(a) P(c) Y: P(c) P(b) P(d) Z: P(a) P(c) P(d)
 (D) X: P(a) P(b) P(c) Y: P(c) P(b) P(d) Z: P(c) P(d) P(a)

Answer:-(B)

Exp:- Suppose X performs P(b) and preempts, Y gets chance, but cannot do its first wait i.e., P(b), so waits for X, now Z gets the chance and performs P(a) and preempts, next X gets chance. X cannot continue as wait on 'a' is done by Z already, so X waits for Z. At this time Z can continue its operations as down on c and d. Once Z finishes, X can do its operations and so Y. In any of execution order of X, Y, Z one process can continue and finish, such that waiting is not circular. In options (A),(C) and (D) we can easily find circular wait, thus deadlock

11. An index is clustered, if
 (A) it is on a set of fields that form a candidate key
 (B) it is on a set of fields that include the primary key
 (C) the data records of the file are organized in the same order as the data entries of the index
 (D) the data records of the file are organized not in the same order as the data entries of the index

Answer:-(C)

Exp:- Clustered index is built on ordering non key field and hence if the index is clustered then the data records of the file are organized in the same order as the data entries of the index.

12. Assume that source S and destination D are connected through two intermediate routers labeled R. Determine how many times each packet has to visit the network layer and the data link layer during a transmission from S to D.

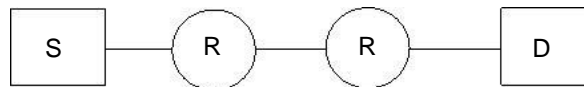

- (A) Network layer – 4 times and Data link layer-4 times
 (B) Network layer – 4 times and Data link layer-3 times
 (C) Network layer – 4 times and Data link layer-6 times
 (D) Network layer – 2 times and Data link layer-6 times

Answer:-(C)

Exp:-

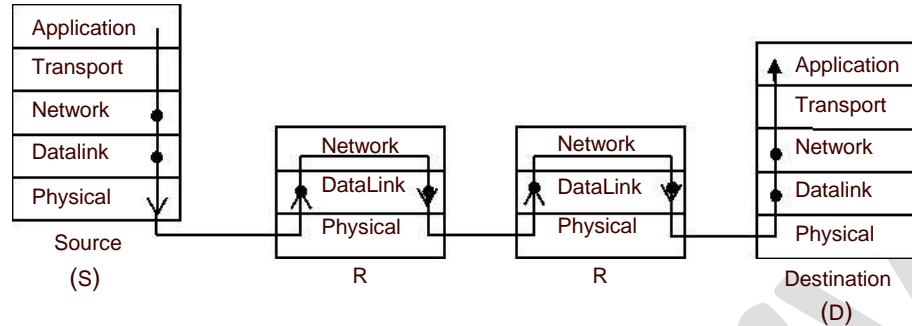

From above given diagram, its early visible that packet will visit network layer 4 times, once at each node [S, R, R, D] and packet will visit Data Link layer 6 times. One time at S and one time at D, then two times for each intermediate router R as data link layer is used for link to link communication.

Once at packet reaches R and goes up from physical –DL–Network and second time when packet coming out of router in order Network – DL– Physical

13. The transport layer protocols used for real time multimedia, file transfer, DNS and email, respectively are
- (A) TCP, UDP, UDP and TCP (B) UDP, TCP, TCP and UDP
 (C) UDP, TCP, UDP and TCP (D) TCP, UDP, TCP and UDP

Answer:- (C)

Exp:- Real time multimedia needs connectionless service, so under lying transport layer protocol used is UDP

File transfer runs over TCP protocol with port no-21

DNS runs over UDP protocol within port no-53

Email needs SMTP protocol which runs over TCP protocol within port no – 25

14. Using public key cryptography, X adds a digital signature σ to message M, encrypts $\langle M, \sigma \rangle$, and sends it to Y, where it is decrypted. Which one of the following sequences of keys is used for the operations?
- (A) Encryption: X's private key followed by Y's private key; Decryption: X's public key followed by Y's public key
 (B) Encryption: X's private key followed by Y's public key; Decryption: X's public key followed by Y's private key
 (C) Encryption: X's public key followed by Y's private key; Decryption: Y's public key followed by X's private key
 (D) Encryption: X's private key followed by Y's public key; Decryption: Y's private key followed by X's public key

Answer:-(D)

Exp:-

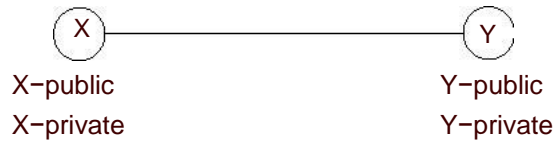

Encryption

- Source has to encrypt with its private key for forming Digital signature for Authentication.
- source has to encrypt the M, α with Y's public key to send it confidentially

Decryption

- Destination Y has to decrypt first with its private key, then decrypt using source public key

15. Match the problem domains in Group I with the solution technologies in Group II.

Group I	Group II
(p) Services oriented computing	(1) Interoperability
(q) Heterogeneous communicating systems	(2) BPMN
(R) Information representation	(3) Publish-find bind
(S) Process description	(4) XML
(A) P – 1, Q – 2, R – 3, S – 4	(B) P – 3, Q – 4, R – 2, S – 1
(C) P – 3, Q – 1, R – 4, S – 2	(D) P – 4, Q – 3, R – 2, S – 1

Answer:-(C)

16. A scheduling algorithm assigns priority proportional to the waiting time of a process. Every process starts with priority zero (the lowest priority). The scheduler re-evaluates the process priorities every T time units and decides the next process to schedule. Which one of the following is TRUE if the processes have no I/O operations and all arrive at time zero?

- (A) This algorithm is equivalent to the first-come-first-serve algorithm
- (B) This algorithm is equivalent to the round-robin algorithm
- (C) This algorithm is equivalent to the shortest-job-first algorithm
- (D) This algorithm is equivalent to the shortest-remaining-time-first algorithm

Answer:-(B)

Exp:- The given scheduling definition takes two parameters, one is dynamically assigned process priority and the other is 'T' time unit to re-evaluate the process priorities.

This dynamically assigned priority will be deciding processes order in ready queue of round robin algorithm whose time quantum is same as 'T' time units. As all the processes are arriving at the same time, they will be given same priority but soon after first 'T' time burst remaining processes will get higher priorities

17. What is the maximum number of reduce moves that can be taken by a bottom-up parser for a string with tokens ϵ and unit-production i.e., of type $A \rightarrow \epsilon$ and $A \rightarrow a$ to parse a string with tokens $a_1 a_2 a_3 \dots a_{n-1} a_n$?
- (A) $n/2$ (B) $n-1$ (C) $2n-1$ (D) $2n$

Answer: -(B)

Exp:- To have maximum number of reduce moves, all the productions will be of the type $A \rightarrow \alpha\beta$ (where α and β could be terminals or non-terminals). Consider the following illustration then:

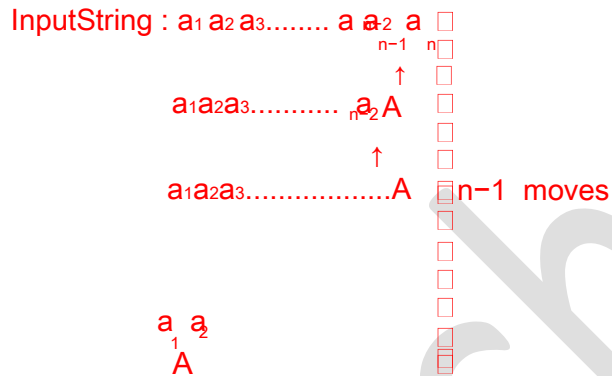

18. Consider the languages $L_1 = \Phi$ and $L_2 = \{a\}$. Which one of the following represents $L_1 L_2^* U L_1^*$?
- (A) $\{\epsilon\}$ (B) Φ (C) a^* (D) $\{\epsilon, a\}$

Answer: -(A)

Exp:- Concatenation of empty language with any language will give the empty language and $L_1^* = \Phi^* = \epsilon$. Hence $L_1 L_2^* U L_1^* = \{\epsilon\}$

19. Which one of the following is the tightest upper bound that represents the time complexity of inserting an object into a binary search tree of n nodes?
- (A) $O(1)$ (B) $O(\log n)$ (C) $O(n)$ (D) $O(n \log n)$

Answer: -(C)

Exp:- For skewed binary search tree on n nodes, the tightest upper bound to insert a node is $O(n)$

20. Which one of the following is the tightest upper bound that represents the number of swaps required to sort n numbers using selection sort?
- (A) $O(\log n)$ (B) $O(n)$ (C) $O(n \log n)$ (D) $O(n^2)$

Answer: -(B)

Exp:- The maximum number of swaps that takes place in selection sort on n numbers is n

21. In the following truth table, $V = 1$ if and only if the input is valid.

Inputs				Outputs		
D_0	D_1	D_2	D_3	X_0	X_1	V
0	0	0	0	X	X	0
1	0	0	0	0	0	1
X	1	0	0	0	1	1
X	X	1	0	1	0	1
X	X	X	1	1	1	1

What function does the truth table represent?

- (A) Priority encoder (B) Decoder
(C) Multiplexer (D) Demultiplexer

Answer: -(A)

Exp:- 4 to 2 priority encoder.

22. The smallest integer that can be represented by an 8-bit number in 2's complement form is
(A) -256 (B) -128 (C) -127 (D) 0

Answer: -(B)

Exp:- $-2^{8-1} = -128$. Range is $-2^{(n-2)}$ to $+2^{(n-1)} - 1$

23. Which one of the following does NOT equal $\begin{vmatrix} 1 & x & x_2 \\ 1 & y & y_2 \\ 1 & z & z_2 \end{vmatrix}$?

(A) $\begin{vmatrix} 1 & x(x+1) & x+1 \\ 1 & y(y+1) & y+1 \\ 1 & z(z+1) & z+1 \end{vmatrix}$

(B) $\begin{vmatrix} 1 & x+1 & x+1 \\ 1 & y+1 & y_2+1 \\ 1 & z+1 & z_2+1 \end{vmatrix}$

(C) $\begin{vmatrix} 0 & x-y & x^2 - y^2 \\ 0 & y-z & y_2 - z_2 \\ 1 & z & z_2 \end{vmatrix}$

(D) $\begin{vmatrix} 2 & x+y & x^2 + y^2 \\ 2 & y+z & y_2 + z_2 \\ 1 & z & z_2 \end{vmatrix}$

Answer: - (A)

Exp:- If matrix B is obtained from matrix A by replacing the l th row by itself plus k times the m th row, for $l \neq m$ then $\det(B) = \det(A)$. With this property given matrix is equal to the matrices given in options (B), (C) and (D).

24. Suppose p is number of cars per minute passing through a certain road junction between 5 PM and 6PM, and p has a Poisson distribution with mean 3. What is the probability of observing fewer than 3 cars during any given minute in this interval?

- (A) $8/(2e^3)$ (B) $9/(2e^3)$ (C) $17/(2e^3)$ (D) $26/(2e^3)$

Answer:-(C)

Exp:- $P(p < 3) = P(p=0) + P(p=1) + P(p=2)$

$$= \frac{e^{-\lambda} \lambda^0}{0!} + \frac{e^{-\lambda} \lambda^1}{1!} + \frac{e^{-\lambda} \lambda^2}{2!} \quad (\text{where } \lambda = 3)$$

$$= e^{-3} + e^{-3} \times 3 + \frac{e^{-3} \times 9}{2}$$

$$= e^{-3} \left[1 + 3 + \frac{9}{2} \right] = \frac{17}{2} e^{-3}$$

25. A binary operation \oplus on a set of integers is defined as $x \oplus y = x + y$

- (A) Commutative but not associative (B) Both commutative and associative
 (C) Associative but not commutative (D) Neither commutative nor associative
- Which one of the following statements is TRUE about \oplus ?

Answer:- (A)

Exp:-

$$x \oplus y = x + y = y + x = y \oplus x$$

Not associative, since, for example

$$(1 \oplus 2) \oplus 3 \neq 1 \oplus (2 \oplus 3)$$

Q. No. 26 – 51 Carry Two Marks Each

26. Which one of the following is NOT logically equivalent to $\neg \exists x (\forall y (\alpha) \wedge \forall z (\beta))$?

- (A) $\forall x (\exists z (\neg \beta) \rightarrow \forall y (\alpha))$ (B) $\forall x (\forall z (\beta) \rightarrow \exists y (\neg \alpha))$
 (C) $\forall x (\forall y (\alpha) \rightarrow \exists z (\neg \beta))$ (D) $\forall x (\exists y (\neg \alpha) \rightarrow \exists z (\neg \beta))$

Answer: -(A) and (D) [marks to all]

Exp:- $\neg \exists x (\forall y (\alpha) \wedge \forall z (\beta))$

$$\equiv \forall x (\forall y (\alpha) \wedge \forall z (\beta) \rightarrow \text{false}) \quad \text{option "C"} \quad \because \neg (p \wedge q) \equiv \neg p \vee \neg q$$

$$\equiv \forall x (\forall z (\beta) \rightarrow \exists y (\neg \alpha)) \quad \text{option "B"} \quad \because \neg (p \wedge q) \equiv \neg p \vee \neg q$$

$$[\because p \Rightarrow q \equiv \neg q \Rightarrow \neg p]$$

27. A RAM chip has a capacity of 1024 words of 8 bits each. The number of 2×4 decoders with enable line needed to construct a 16K \times 16 RAM from 1K \times 8 RAM is

- (A) 4 (B) 5 (C) 6 (D) 7

Answer: -(B)

Exp:- RAM chip size = $1k \times 8$ 1024 words of 8 bits each

RAM to construct = $16k \times 16$

Number of chips required = $\frac{16k \times 16}{1k \times 8} = 16 \times 2$ [16 chips vertically with each having 2 chips

horizontally]

So to select one chip out of 16 vertical chips, we need 4 x 16 decoder.

Available decoder is – 2 x 4 decoder

To be constructed is 4 x 16 decoder

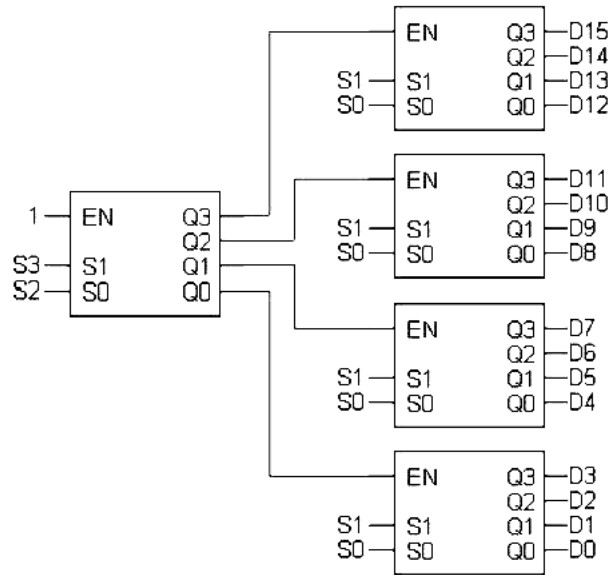

So we need 5, 2 x 4 decoder in total to construct 4 x 16 decoder.

28. Consider an instruction pipeline with five stages without any branch prediction: Fetch Instruction (FI), Decode Instruction (DI), Fetch Operand (FO), Execute Instruction (EI) and Write Operand (WO). The stage delays for FI, DI, FO, EI and WO are 5 ns, 7 ns, 10 ns, 8 ns and 6 ns, respectively. There are intermediate storage buffers after each stage and the delay of each buffer is 1 ns. A program consisting of 12 instructions $I_1, I_2, I_3, \dots, I_{12}$ is executed in this pipelined processor. Instruction I_4 is the only branch instruction and its branch target is I_9 . If the branch is taken during the execution of this program, the time (in ns) needed to complete the program is

- (A) 132 (B) 165 (C) 176 (D) 328

Answer: - (B)

Exp:- Clock period = Maximum stage delay + overhead (Buffer) = $10 + 1 = 11$ ns

Assume FI-1, DI-2, FO-3, EI-4, WO-5

```

l1 : 1 2 3 4 5
l2 : - 1 2 3 4 5
l3 : -- 1 2 3 4 5
l4 : --- 1 2 3 4 5
l5 : ---- 1 2 3 4 5
l6 : ----- 1 2 3 4 5
l7 : ----- 1 2 3 4 5
l8 : ----- 1 2 3 4 5
l9 : ----- 1 2 3 4 5
l10: ----- 1 2 3
l11: ----- 1 2 3 4 5 4 5
l12: ----- 1 2 3 4 5
    
```

So number of clocks required to complete the program is = 15 clocks and time taken is = 15 × 11 ns = 165 ns.

29. Consider the following operation along with Enqueue and Dequeue operations on queues, where k is a global parameter

```

MultiDequeue Q {
    m = k
    while (Q is not empty and m > 0) {
        Dequeue(Q)
        m = m - 1
    }
}
    
```

What is the worst case time complexity of a sequence of n queue operations on an initially empty queue?

- (A) $\Theta(n)$ (B) $\Theta(n + k)$ (C) $\Theta(nk)$ (D) $\Theta(n^2)$

Answer:- (A)

Exp:- Initially the queue is empty and we have to perform n operations.

i) One option is to perform all Enqueue operations i.e. n Enqueue operations. Complexity will be $\theta(n)$

or

ii) We can perform a mix of Enqueue and Dequeue operations. It can be Enqueue for first n/2 times and then Dequeue for next n/2, or Enqueue and Dequeue alternately, or any permutation of Enqueues and Dequeues totaling 'n' times. Complexity will be $\theta(n)$

or

iii) We can perform Enqueues and MultiDequeues. A general pattern could be as follows:

Enqueue Enqueue ... (k times) MultiDequeue Enqueue Enqueue ... (k times) MultiDequeue ... Up to total n

--- k items enqueued ----k items deleted---k items enqueued----k items deleted -- and so on.

The number of times this k-Enqueues, MutiDequeue cycle is performed = $n/k + 1$

So, Complexity will be k times Enqueue + 1 MultiDequeue) $\times (n/k + 1)$

Which is $\theta(2k \times (n/k + 1)) = \theta(n)$ or

iv) We can just perform n MultiDequeues (or n Dequeues for that matter):

Each time the while condition is false (empty queue), condition is checked just once for each of the 'n' operations. So $\theta(n)$.

30. The preorder traversal sequence of a binary search tree is 30, 20, 10, 15, 25, 23, 39, 35, 42. Which one of the following is the postorder traversal sequence of the same tree?

- (A) 10,20,15,23,25,35,42,39,30 (B) 15,10,25,23,20,42,35,39,30
 (C) 15,20,10,23,25,42,35,39,30 (D) 15,10,23,25,20,35,42,39,30

Answer:-(D)

Exp:- Preorder :30,20,10,15,25,23,39,35, 42

Inorder :10,15,20,23,25,30,35,39, 42

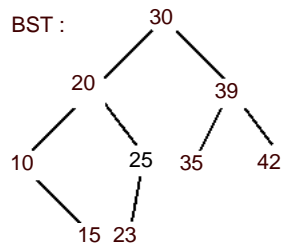

31.

What is the return value of $f(p, p)$ if the value of p is initialized to 5 before the call? Note that the first parameter is passed by reference, whereas the second parameter is passed by value.

```

int f (int & x, int c) {
    c= c-1;
    if(c== 0) return 1;
    x= x+1;
    ( )
} return f x,c *x;
    
```

- (A) 3024 (B) 6561 (C) 55440 (D) 161051

Answer:-(B)

Exp:-

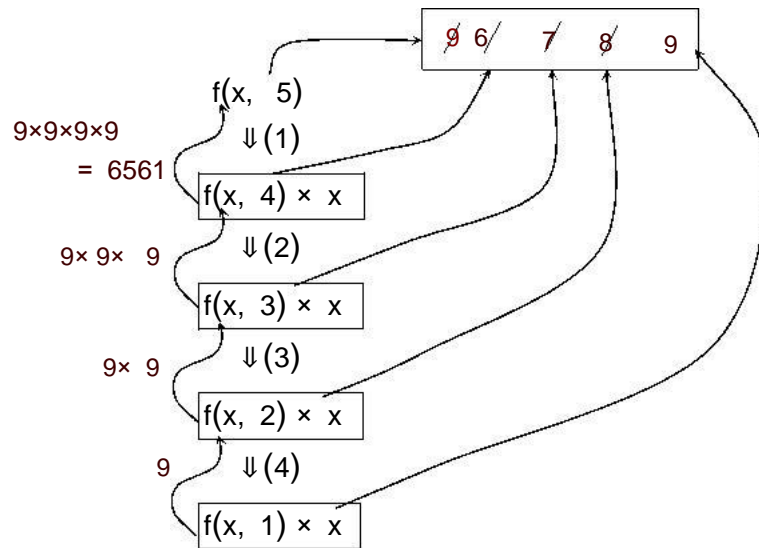

32. Which of the following is/are undecidable?

1. G is a CFG. Is $L(G) = \Phi$?
2. G is a CFG. IS $L(G) = \Sigma^*$?
3. M is a Turing machine. Is $L(M)$ regular?
4. A is a DFA and N is a NFA. Is $L(A) = L(N)$?

(A) 3 only (B) 3 and 4 only (C) 1, 2 and 3 only (D) 2 and 3 only

Answer: -(D)

Exp:- There is an algorithm to check whether the given CFG is empty, finite or infinite and also to convert NFA to DFA hence 1 and 4 are decidable

33. Consider the following two sets of LR(1) items of an LR(1) grammar

$$\begin{array}{ll} X \rightarrow c.X, c/d & X \rightarrow c.X, \$ \\ X \rightarrow .cX, c/d & X \rightarrow .cX, \$ \\ X \rightarrow .d, c/d & X \rightarrow .d, \$ \end{array}$$

Which of the following statements related to merging of the two sets in the corresponding LALR parser is/are FALSE?

1. Cannot be merged since look aheads are different
2. Can be merged but will result in S-R conflict
3. Can be merged but will result in R-R conflict
4. Cannot be merged since goto on c will lead to two different sets

(A) 1 only (B) 2 only (C) 1 and 4 only (D) 1, 2, 3 and 4

Answer:-(D)
Exp:-

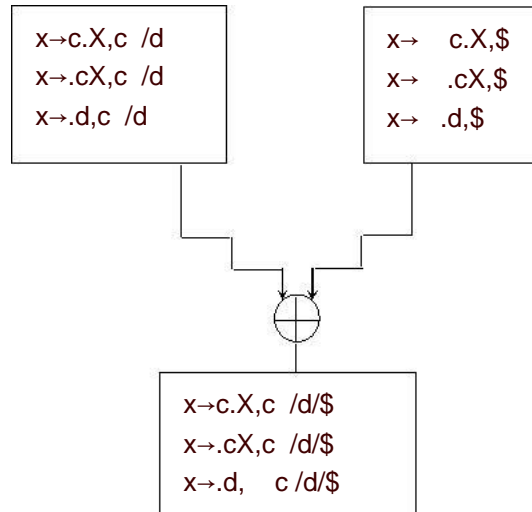

1. Merging of two states depends on core part (production rule with dot operator), not on look aheads.
 2. The two states are not containing Reduce item ,So after merging, the merged state can not contain any S-R conflict
 3. As there is no Reduce item in any of the state, so can't have R-R conflict.
 4. Merging of stats does not depend on further goto on any terminal.
- So all statements are false.

34. A certain computation generates two arrays a and b such that $a[i]= f(i)$ for $0 \leq i < n$ and $b[i]= g(a[i])$ for $0 \leq i < n$. Suppose this computation is decomposed into two concurrent processes X and Y such that X computes the array a and Y computes the array b. The processes employ two binary semaphores R and S, both initialized to zero. The array a is shared by the two processes. The structures of the processes are shown below.

```

Process X;                Process Y;
private i;                private i;
for(i= 0; i< n; i++) {    for(i= 0; i< n; i++) {
    a[i]= f(i);            EntryY( R, S ;
    }                      b[i]= g(a[i]);
    ExitX( R, S ;        }
    }
    
```

Which one of the following represents the CORRECT implementations of ExitX and EntryY?

- | | |
|--|--|
| <p>(A) ExitX(R, S {
P(R ;
} V S ;

EntryY(R, S {
P(S ;
} V R ;</p> | <p>(B) ExitX(R, S {
V(R ;
} V S ;

EntryY(R, S {
P(R ;
} P S ;</p> |
|--|--|

```
(C) ExitX( ) R, S {
    P(S);
} V R ;

EntryY( ) R, S {
    V(S);
} P R ;
```

```
(D) ExitX( ) R, S {
    V(R);
} P S ;

EntryY( ) R, S {
    V(S);
} P R ;
```

Answer:-(C)

Exp:- For computing both the array a[] and b[], first element a[i] should be computed using which b[i] can be computed. So process X and Y should run in strict alteration manner, starting with X. This requirement meets with implementation of ExitX and EntryY given in option C.

35. The following figure represents access graphs of two modules M1 and M2. The filled circles represent methods and the unfilled circles represent attributes. IF method m is moved to module M2 keeping the attributes where they are, what can we say about the average cohesion and coupling between modules in the system of two modules?

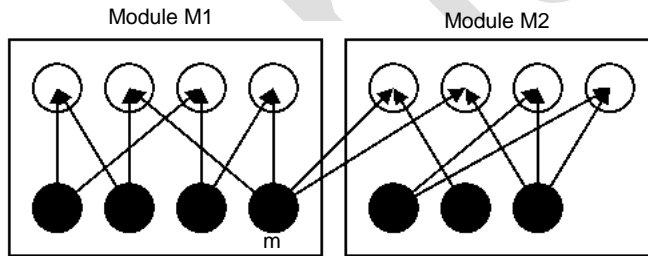

- (A) There is no change
- (B) Average cohesion goes up but coupling is reduced
- (C) Average cohesion goes down and coupling also reduces
- (D) Average cohesion and coupling increase

Answer:-(A)

Exp:-

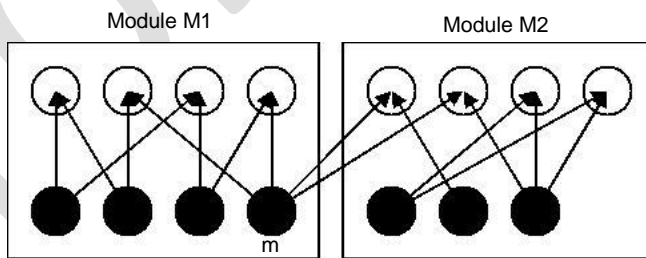

$$\text{Coupling} = \frac{\text{number of external links}}{\text{number of modules}} = \frac{2}{2}$$

$$\text{Cohesion of a module} = \frac{\text{number of internal links}}{\text{number of methods}}$$

$$\text{Cohesion of } M_1 = \frac{8}{4}; \text{ Cohesion of } M_2 = \frac{6}{3}; \text{ Average cohesion} = 2$$

After moving method m to M2, graph will become

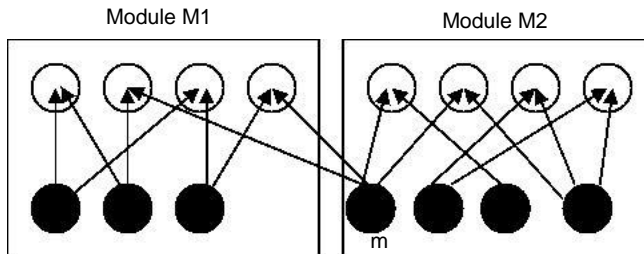

$$\text{Coupling} = \frac{2}{2}$$

$$\text{Cohesion of } M_1 = \frac{6}{3}; \text{ Cohesion of } M_2 = \frac{8}{4}; \text{ Average cohesion} = 2$$

∴ answer is no change

36. In an IPv4 datagram, the M bit is 0, the value of HLEN is 10, the value of total length is 400 and the fragment offset value is 300. The position of the datagram, the sequence numbers of the first and the last bytes of the payload, respectively are
- (A) Last fragment, 2400 and 2789 (B) First fragment, 2400 and 2759
 (C) Last fragment, 2400 and 2759 (D) Middle fragment, 300 and 689

Answer:-(C)

Exp:- M= 0 – Means there is no fragment after this, i.e. Last fragment
 HLEN=10 - So header length is $4 \times 10 = 40$, as 4 is constant scale factor
 Total Length = 400 (40 Byte Header + 360 Byte Payload)
 Fragment Offset = 300, that means 300×8 Byte = 2400 bytes are before this last fragment
 So the position of datagram is last fragment
 Sequence number of First Byte of Payload = 2400 (as 0 to 2399 Sequence no are used)
 Sequence number of Last Byte of Payload = $2400 + 360 - 1 = 2759$

37. Determine the maximum length of cable (in km) for transmitting data at a rate of 500 Mbps in an Ethernet LAN with frames of size 10,000 bits. Assume the signal speed in the cable to be 2,00,000 km/s
- (A) 1 (B) 2 (C) 2.5 (D) 5

Answer:-(B)

Exp:- 500×10^6 bits ----- 1 sec
 $\therefore 10^4$ bits ----- $\frac{5 \times 10^8}{10^4} = \frac{10^4}{5 \times 10^8}$ sec = $\frac{1}{5 \times 10^4}$ sec
 1 sec ----- 2×10^5 km
 $\therefore \frac{1}{5 \times 10^4}$ sec ----- $\frac{2 \times 10^5}{5 \times 10^4} = 4$ km
 \therefore Maximum length of cable = $\frac{4}{2} = 2$ km

38. Consider the following relational schema.
 Students(rollno: integer, sname: string)
 Courses(courseno: integer, cname: string)
 Registration(rollno: integer, courseno; integer, percent: real)
 Which of the following queries are equivalent to this query in English?
 "Find the distinct names of all students who score more than 90% in the course numbered 107"
- (I) $\text{SELECT DISTINCT S.sname}$
 $\text{FROM Students as S, Registration as R}$
 $\text{WHERE R.rollno=S.rollno AND R.CourseNo=107 AND R.percent>90}$
- (II) $\Pi_{\text{sname}} (\sigma_{\text{courseno}=107 \wedge \text{percent} > 90} (\text{Registration} \bowtie \text{Students}))$
- (III) $\{T \mid \exists S \in \text{Students}, \exists R \in \text{Registration} (S.\text{rollno} = R.\text{rollno} \wedge R.\text{courseno} = 107 \wedge R.\text{percent} > 90 \wedge T.\text{sname} = S.\text{sname})\}$
- (IV) $\{ \langle S_N \rangle \mid \exists S_R \exists R_P (\langle S_R, S_N \rangle \in \text{Students} \wedge \langle S_R, 107, R_P \rangle \in \text{Registration} \wedge R_P > 90) \}$
- (A) I, II, III and IV
 (B) I, II and III only
 (C) I, II and IV only
 (D) II, III and IV only

Answer:- (A)

Exp:- Four queries given in SQL, RA, TRC and DRC in four statements respectively retrieve the required information.

39. A shared variable x, initialized to zero, is operated on by four concurrent processes W, X, Y, Z as follows. Each of the processes W and X reads x from memory, increments by one, stores it to memory, and then terminates. Each of the processes Y and Z reads x from memory, decrements by two, stores it to memory, and then terminates. Each process before reading x invokes the P operation (i.e., wait) on a counting semaphore S and invokes the V operation (i.e., signal) on the semaphore S after storing x to memory. Semaphore S is initialized to two. What is the maximum possible value of x after all processes complete execution? (D) 2

Answer:-(D)

Exp:-

	W	X	Y	Z
1	R(x)	R(x)	R(x)	R(x)
2	x++	x++	x=x-2;	x=x-2;
3	w(x)	w(x)	w(x)	w(x)

R(x) is to read x from memory, w(x) is to store x in memory

(I) $w_1(x \boxed{0})$ [W is Preempted]

(II) $Y_1, Y_2, Y_3(x \boxed{-2})$ [Y is completed]

(III) Z_1, Z_2, Z_3 ($x \leftarrow 4$) [Z is completed]

(IV) W_2, W_3 ($x \leftarrow 1$) [It increments local copy of x and stores & W is completed]

(V) X_1, X_2, X_3 ($x \leftarrow 2$) [X is completed]

Maximum value of x = 2

40. Consider the DFA given below.

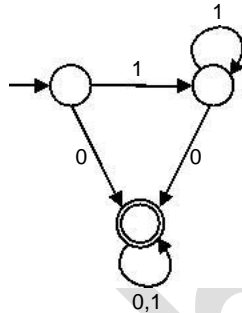

Which of the following are FALSE?

1. Complement of $L(A)$ is context-free
 2. $L(A) = L((11^*0 + 0)(0+1)^*0^*1^*)$
 3. For the language accepted by A, A is the minimal DFA
 4. A accepts all strings over $\{0, 1\}$ of length at least 2
- (A) 1 and 3 only (B) 2 and 4 only (C) 2 and 3 only (D) 3 and 4 only

Answer: - (D)

Exp:-

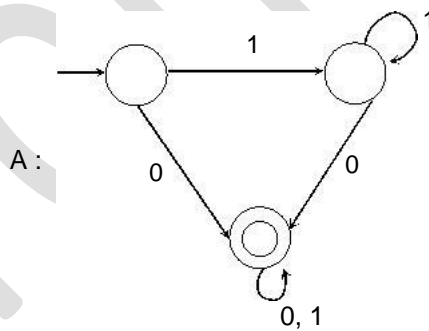

- (1) $L(A)$ is regular, its complement is also regular and if it is regular it is also context free.
- (2) $L(A) = (11^*0 + 0)1^*0^*1^* = 1^*(0+0)1^*$
Language has all strings where each string contains '0'.
- (3) A is not minimal, it can be constructed with 2 states
- (4) Language has all strings, where each string contains '0'. (atleast length one)

41. Consider the following languages

$$L_1 = \{0^p 1^q 0^r \mid p, q, r \geq 0\}$$

Which one of the following statements is FALSE?

- (A) L_2 is context-free
- (B) $L_1 \cap L_2$ is context-free
- (C) Complement of L_2 is recursive
- (D) Complement of L_1 is context-free but not regular

Answer: -(D)

Exp:- $L_1 = \{0^p 1^q 0^r \mid p, q, r \geq 0\}$

$L_1 = \{0^p 1^q 0^r \mid p, q, r \geq 0\}$ is regular
 $L_2 = \{0^p 1^q 0^r \mid p, q, r \geq 0, p \neq r\}$ is CFL

- (A) L_2 is CFL (True)
- (B) $L_1 \cap L_2 = CFL$ (True)
- (C) L_2 complement is recursive (True)
- (D) L_1 complement is CFL but not regular (False as L_1 is regular)

42. Consider the following function

```
int unknown( int n) {
    int i, j, k= 0;
    for(i= n / 2; i<= n; i++)
        for( j= 2; j<= n; j*= 2)
            k= k+ n / 2;
    return( k );
}
```

The return value of the function is

- (A) $\Theta(n^2)$
- (B) $\Theta(n \log n)$
- (C) $\Theta(n^3)$
- (D) $\Theta(n^{3 \log n})$

Answer:- (B)

Exp:- $i = \frac{n}{2}, \frac{n}{2} + 1, \frac{n}{2} + 2, \dots, n$

Repeats

$\frac{n}{2}$ to $n = \frac{n+1}{2}$ times

$J = (2, 2^2, 2^3, 2^4, \dots, n)$
$k = k + \frac{n}{2}$
$k = \Theta(n \log n)$

$$k = \frac{n}{2} + \frac{n}{2} + \dots + \frac{n}{2} \text{ (logn times)} = \frac{n \log n}{2}$$

$$\begin{aligned}
 &= \frac{n \log n}{2} + \frac{n \log n}{2} + \frac{n \log n}{2} + \dots + \frac{n+1}{2} \text{ times} \\
 &= \frac{(n+1) \log n}{2} \cdot n \\
 &= \Theta(n^2 \log n)
 \end{aligned}$$

43. The number of elements that can be sorted in $\Theta(\log n)$ time using heap sort is
 (A) $\Theta(1)$ (B) $\Theta(\sqrt{\log n})$ (C) $\Theta(\log \log n)$ (D) $\Theta(\log n)$

Answer:-(A)

Exp:- After constructing a max-heap in the heap sort, the time to extract maximum element and then heapifying the heap takes $\Theta(\log n)$ time by which we could say that $\Theta(\log n)$ time is required to correctly place an element in sorted array. If $\Theta(\log n)$ time is taken to sort using heap sort, then number of elements that can be sorted is constant which is $\Theta(1)$

44. Consider a hard disk with 16 recording surfaces (0-15) having 16384 cylinders (0) 16383 and each cylinder contains 64 sectors (0-63). Data storage capacity in each sector is 512 bytes. Data are organized cylinder-wise and the addressing format is < cylinder no., sector no.>. A file of size 42797 KB is stored in the disk and the starting disk location of the file is <1200, 9, 40>. What is the cylinder number of the last sector of the file, if it is stored in a contiguous manner?
 (A) 1281 (B) 1282 (C) 1283 (D) 1284

Answer: -(D)

Exp:- $42797 \text{ KB} \equiv \frac{42797 \times 1024}{512} = 85594 \text{ sectors}$

Starting is <1200, 9, 40> contains total $24 + (6 \times 64) = 408$ sectors

Next, 1201, -----, 1283 cylinders contains total $1024 \times 83 = 84992$ sectors

(\because each cylinder contains $16 \times 64 = 1024$ sectors)

\therefore Total = $408 + 84992 = 85400$ sectors

\therefore The required cylinder number is 1284 which will contain the last sector of the file

45. Consider the following sequence of micro-operations

MBR \leftarrow PC

MAR \leftarrow X

PC \leftarrow Y

Memory \leftarrow MBR

Which one of the following is a possible operation performed by this

- sequence?
 (A) Instruction fetch (B) Operand fetch
 (C) Conditional branch (D) Initiation of interrupt service

Answer:-(D)

Exp:- PC content is stored in memory via MBR and PC gets new address from Y. It represents a function call (routine), which is matching with interrupt service initiation

46. The line graph $L(G)$ of a simple graph G is defined as follows:

- There is exactly one vertex $v(e)$ in $L(G)$ for each edge e in G .
- For any two edges e and e' in G , $L(G)$ has an edge between $v(e)$ and $v(e')$, if and only if e and e' are incident with the same vertex in G .

Which of the following statements is/are TRUE?

(P) The line graph of a cycle is a cycle.

(Q) The line graph of a clique is a clique.

(R) The line graph of a planar graph is planar.

(S) The line graph of a tree is a tree.

(B) P and R only

(C) R only

(D) P, Q and S only

Answer: -(A)

Exp:- P) The line graph of a cycle is a cycle

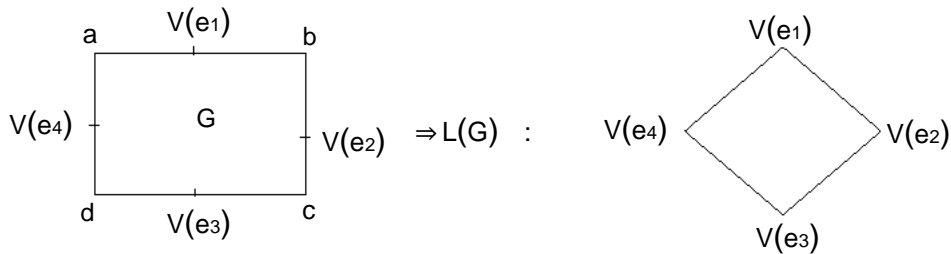

is also cycle graph

R) Line graph of planar graph need not be planar always. Consider the following example. Consider the following planar graph (star graph)

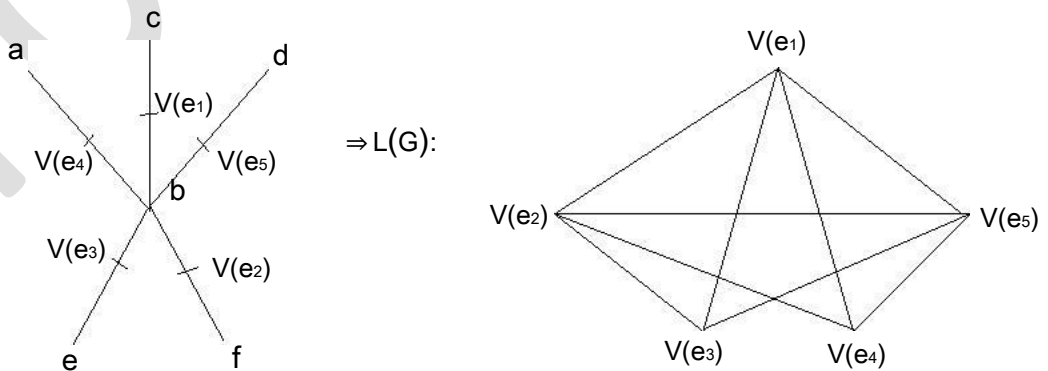

S) Hence line graph of planar graph need not be planar(Here we got K_5 which is not planar).

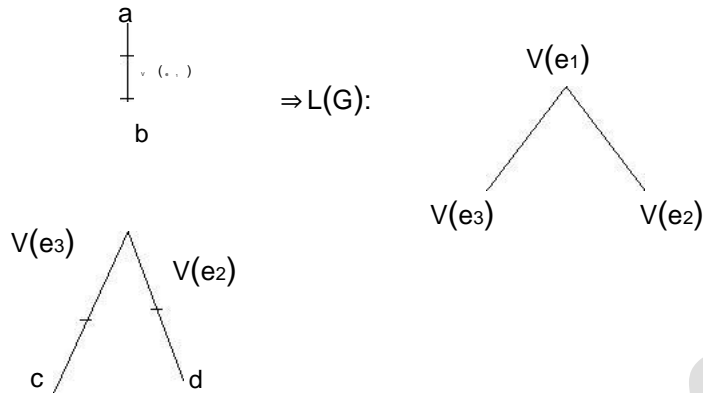

The line graph of a tree need not be tree.

47. What is the logical translation of the following statement?

- “None of my friends are perfect.”
- (A) $\exists x(F(x) \wedge \neg P(x))$ (B) $\exists x(\neg F(x) \wedge P(x))$
- (C) $\exists x(\neg F(x) \wedge \neg P(x))$ (D) $\neg \exists x(F(x) \wedge P(x))$

Answer: -(D)

Exp:- “None of my friends are perfect”

$$= \forall x(F(x) \rightarrow \neg P(x))$$

$$= \forall x(\neg F(x) \vee \neg P(x))$$

$$= \neg \exists x(F(x) \wedge P(x))$$

Common Data Questions: 48 & 49

The procedure given below is required to find and replace certain characters inside an input character string supplied in array A. The characters to be replaced are supplied in array oldc, while their respective replacement characters are supplied in array newc. Array A has a fixed length of five characters, while arrays oldc and newc contain three characters each. However, the procedure is flawed

```

void find_and_replace ( char *A, char *oldc, char *newc ) {
    for (int i= 0; i< 5; i++)
        for (int j=0; j< 3; j++)
            if (A[i]==oldc[j]) A[i]= newc[j];
}
    
```

The procedure is tested with the following four test cases

- (1) oldc= "abc", newc= "dab" (2) oldc= "cde", newc= "bcd"
- (3) oldc= "bca ", newc= "cda" (4) oldc= "abc", newc= "bac"

50. The tester now tests the program on all input strings of length five consisting of characters 'a', 'b', 'c', 'd' and 'e' with duplicates allowed. If the tester carries out this testing with the four test cases given above, how many test cases will be able to capture the flaw?
 (A) Only one (B) Only two (C) Only three (D) All four

Answer:-(B)

Exp:- Flaw in this given procedure is that one character of Array 'A' can be replaced by more than one character of newc array, which should not be so. Test case (3) and (4) identifies this flaw as they are containing 'oldc' and 'newc' array characters arranged in specific manner. Following string can reflect flaw, if tested by test case (3).

<pre> initially i = 0 A = "b cda" oldc = "b ca" newc = "cda" </pre>	<pre> R2 ← R1 + R2 </pre>
<pre> x = c * c; i = 0 </pre>	<pre> R2 ← R2 * R2 [spill c] i = 0 </pre> <p>memory spill to store the value of c in memory</p>
<pre> if (x > a) & j = 1 Next i = 0 { y = a * a; } </pre>	<pre> CMP R2 R1 R2 ← R1 * R1 newc = "cda" </pre>
<pre> else { i = 0 c = c so replaced by d d = c * a; d = d * d; </pre>	<pre> j = 1 R2 ← [spill c] R2 ← R2 * R1 R2 ← [spill c] </pre>

Likewise single character 'b' in A is replaced by 'c' and then by 'd'. Same way test case (4) can also catch the flaw

49. If array A is made to hold the string "abcde", which of the above four test cases will be successful in exposing the flaw in this procedure?
 (A) None (B) 2 only (C) 3 and 4 only (D) 4 only

Answer:-(C)

Exp:- Now for string "abcde" in array A, both test case (3) and (4) will be successful in finding the flaw, as explained in above question. In the above code total number of spills to memory is 1

51. What is the minimum number of registers needed in the instruction set architecture of the processor to compile this code segment without any spill to memory? Do not apply any optimization other than optimizing register allocation. The following code segment is executed on a processor which allows only register operands in its instructions. Each instruction can have at most two source operands and one destination operand.

Answer:-(B)

Exp:- Assume that all variables are dead after this code segment

<pre> d = c * a; c = a + b; e = c + a; x = c * c; </pre>	<pre> R2 ← R1 + R2 </pre>
<pre> if (x > a) { y = a * a; } else { </pre>	<pre> R3 ← R2 * R1 </pre>
<pre> x = c * c; d = d * d; e = e * e; } </pre>	<pre> R4 ← R2 + R1 R2 ← R2 * R2 </pre>

if(x> a)	CMP R ₂ R ₁
{ y= a*a; }	R ₁ ←R ₁ *R ₁
else { d= d*d; e= e*e; }	R ₃ ←R ₃ *R ₃ R ₄ ←R ₄ *R ₄

In the above code minimum number of registers needed are = 4

Linked Answer Questions: Q.52 to Q.55 Carry Two Marks Each

Statement for Linked Answer Questions: 52 & 53

Relation R has eight attributes ABCDEFGH. Fields of R contain only atomic values.

F={CH→ G, A→ BC, B→ CFH, E→ A, F→ EG} is a set of functional dependencies (FDs) so that F⁺ is exactly the set of FDs that hold for R

52. How many candidate keys does the relation R have?
 (A) 3 (B) 4 (C) 5 (D) 6

Answer:-(B)

Exp:- Candidate keys are AD, BD, ED and FD

53. The relation R is
 (A) in 1NF, but not in 2NF (B) in 2NF, but not in 3NF
 (C) in 3NF, but not in BCNF (D) in BCNF

Answer:-(A)

Exp:- A→ BC, B→ CFH and F→ EG are partial dependencies. Hence it is in 1NF but not in 2NF

Statement for Linked Answer Questions: 54 & 55

A computer uses 46-bit virtual address, 32-bit physical address, and a three-level paged page table organization. The page table base register stores the base address of the first-level table (T₁), which occupies exactly one page. Each entry of T₁ stores the base address of a page of the second-level table (T₂). Each entry of T₂ stores the base address of a page of the third-level table (T₃). Each entry of T₃ stores a page table entry (PTE). The PTE is 32 bits in size. The processor used in the computer has a 1 MB 16 way set associative virtually indexed physically tagged cache. The cache block size is 64 bytes.

54. What is the size of a page in KB in this computer?
 (A) 2 (B) 4 (C) 8 (D) 16

Answer:-(C)

Exp:- Let the page size be 2^x Bytes.
Then, the page offset = x bits

$46-x$	x
--------	-----

Now, we are using 3-level paging. First level page table is contained in one page. Each page table entry is 32-bit.

$$\text{The size of } T_3 \text{ is } = \frac{2^{46} * 2_2}{2_x} = 2^{46+2-x} \quad [\because \text{PTE}=32 \text{ bit} = 4\text{B} = 2_2\text{B}]$$

$$\text{The size of } T_2 \text{ is } = \frac{2^{46+2-x} * 2_2}{2_x} = 2^{46+4-2x}$$

$$\text{The size of } T_1 \text{ is } = \frac{2^{46+4-2x} * 2_2}{2_x} = 2^{46+6-3x} = 2^x \quad [T_1 \text{ occupies exactly one page}]$$

$$\therefore 46 + 6 - 3x = x \Rightarrow x = 13$$

$$\text{So, page size } = 2^{13} \text{ kB} = 8 \text{ kB.}$$

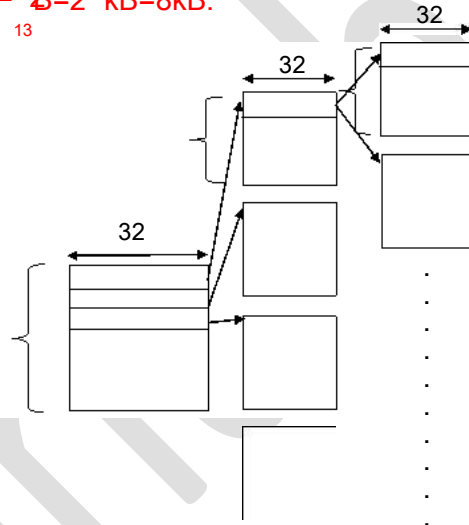

55. What is the minimum number of page colours needed to guarantee that no two synonyms map to different sets in the processor cache of this computer?
(A) 2 (B) 4 (C) 8 (D) 16

Answer:- (C)

Exp:- As the page size is 2^{13} Bytes and page coloring is asked so we divide cache size by page size and group 16 pages in one set.

$$\text{Number of pages in cache} = 1\text{MB} / 8\text{KB} = 128 \text{ pages}$$

$$\text{Number of set in cache} = 128 / 16 = 8 \text{ sets}$$

Take any page of LAS, it will be mapped with cache on any one of these 8 sets (set association mapping). For any two synonym to map with same set they should be colored with same color of that respective set. So minimum we need 8 colors for this mapping.

Q. No. 56 – 60 Carry One Mark Each

56. Complete the sentence:
Universalism is to particularism as diffuseness is to _____
(A) specificity (B) neutrality (C) generality (D) adaptation

Answer:-(A)

Exp:- The relation is that of antonyms

57. Were you a bird, you _____ in the sky.
(A) would fly (B) shall fly
(C) should fly (D) shall have flown

Answer:-(A)

58. Which one of the following options is the closest in meaning to the word given below?
Nadir
(A) Highest (B) Lowest (C) Medium (D) Integration

Answer:-(B)

Exp:- Nadir in the lowest point on a curve

59. Choose the grammatically INCORRECT sentence:
(A) He is of Asian origin (B) They belonged to Africa
(C) She is an European (D) They migrated from India to Australia

Answer:-(C)

60. What will be the maximum sum of 44, 42, 40, ... ?
(A) 502 (B) 504 (C) 506 (D) 500

Answer:-(C)

Exp:- The maximum sum is the sum of 44, 42, - - - -2.
The sum of 'n' terms of an AP

$$= \frac{n}{2}$$

$$[2a + (n-1)d]$$

In this case, $n = 22$, $a = 44$ and $d = -2$

$$\therefore \text{Sum} = \frac{22}{2} [2 \times 44 + (22-1) \times (-2)] = 11 [88 - 42] = 11 \times 46 = 506$$

Q. No. 61 – 65 Carry Two Marks Each

61. Out of all the 2-digit integers between 1 and 100, a 2-digit number has to be selected at random. What is the probability that the selected number is not divisible by 7?
(A) 13/90 (B) 12/90 (C) 78/90 (D) 77/90

Answer:- (D)

Exp:- The number of 2 digit multiples of 7 = 13

∴ Probability of choosing a number

$$\text{Not divisible by 7} = \frac{90-13}{90} = \frac{77}{90}$$

62. A tourist covers half of his journey by train at 60 km/h, half of the remainder by bus at 30 km/h and the rest by cycle at 10 km/h. The average of the tourist in km/h during his entire journey is

- (A) 36 (B) 30 (C) 24 (D) 18

Answer:- (C)

Exp:- Let the total distance covered be 'D'

$$\text{Now, average speed} = \frac{D}{\text{Total time taken}}$$

$$= \frac{D}{\frac{D}{60} + \frac{D}{30} + \frac{D}{10}} = \frac{1}{\frac{1}{120} + \frac{1}{120} + \frac{1}{40}} = \frac{120}{5} = 24 \text{ km / hr}$$

63. Find the sum of the expression

$$\frac{1}{1+2} + \frac{1}{2+3} + \frac{1}{3+4} + \dots + \frac{1}{80+81}$$

- (A) 7 (B) 8 (C) 9 (D) 10

Answer:- (B)

Exp:- The expression can be written as

$$\begin{aligned} & \frac{1}{\sqrt{1}+\sqrt{2}} + \frac{1}{\sqrt{2}+\sqrt{3}} + \frac{1}{\sqrt{3}+\sqrt{4}} + \dots + \frac{1}{\sqrt{80}+\sqrt{81}} \\ &= \frac{\sqrt{2}-\sqrt{1}}{(\sqrt{2})^2-(\sqrt{1})^2} + \frac{\sqrt{3}-\sqrt{2}}{(\sqrt{3})^2-(\sqrt{2})^2} + \frac{\sqrt{4}-\sqrt{3}}{(\sqrt{4})^2-(\sqrt{3})^2} + \dots + \frac{\sqrt{81}-\sqrt{80}}{(\sqrt{81})^2-(\sqrt{80})^2} \\ &= \sqrt{81}-\sqrt{1} = 8 \end{aligned}$$

64. The current erection cost of a structure is Rs. 13,200. If the labour wages per day increase by 1/5 of the current wages and the working hours decrease by 1/24 of the current period, then the new cost of erection in Rs. is

- (A) 16,500 (B) 15,180 (C) 11,000 (D) 10,120

Answer:- (B)

Exp:- Let 'W' be the labour wages, and 'T' be the working hours.

Now, total cost is a function of W × T

Increase in wages = 20%

∴ Revised wages = 1.2 W

$$\text{Decrease in labour time} = \frac{100}{24}$$

□

$$\therefore \text{Revised time} = \frac{100}{24} - \frac{100}{24} T = 23 T$$

$$\therefore \text{Revised Total cost} = 1.2 \times \frac{23}{24} WT = 1.15WT$$

$$= 1.15 \times 13200 = 15180$$

65. After several defeats in wars, Robert Bruce went in exile and wanted to commit suicide. Just before committing suicide, he came across a spider attempting tirelessly to have its net. Time and again, the spider failed but that did not deter it to refrain from making attempts. Such attempts by the spider made Bruce curious. Thus, Bruce started observing the near-impossible goal of the spider to have the net. Ultimately, the spider succeeded in having its net despite several failures. Such act of the spider encouraged Bruce not to commit suicide. And then, Bruce went back again and won many a battle, and the rest is history.
- Which one of the following assertions is best supported by the above information?
- (A) Failure is the pillar of success (B) Honesty is the best policy
 (C) Life begins and ends with adventures (D) No adversity justifies giving up hope

Answer:- (D)