

Mode 1 Operation

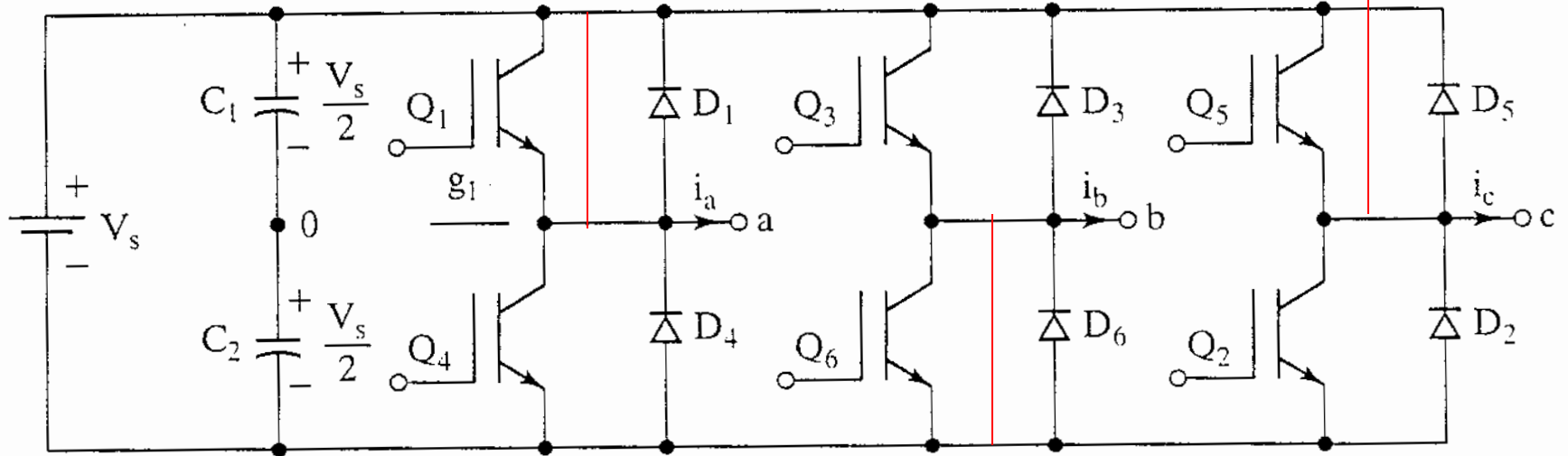

Mode 1 Operation

$$0 \leq \omega t \leq \frac{\pi}{3}$$

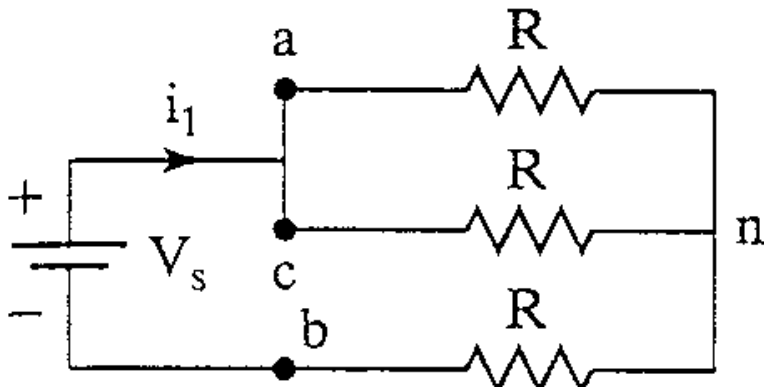

Q_1, Q_5, Q_6 conduct

$$R_{eq} = R + \frac{R}{2} = \frac{3R}{2}$$

$$i_1 = \frac{V_s}{R_{eq}} = \frac{2V_s}{3R}$$

$$v_{an} = v_{cn} = \frac{i_1 R}{2} = \frac{V_s}{3}$$

$$v_{bn} = -i_1 R = \frac{-2V_s}{3}$$

Summary Table

TABLE 6.2 Switch States for Three-Phase Voltage-Source Inverter (VSI)

State	State No.	Switch States	v_{ab}	v_{bc}	v_{ca}
$S_1, S_2,$ and S_6 are on and $S_4, S_5,$ and S_3 are off	1	100	V_S	0	$-V_S$
$S_2, S_3,$ and S_1 are on and $S_5, S_6,$ and S_4 are off	2	110	0	V_S	$-V_S$
$S_3, S_4,$ and S_2 are on and $S_6, S_1,$ and S_5 are off	3	010	$-V_S$	V_S	0
$S_4, S_5,$ and S_3 are on and $S_1, S_2,$ and S_6 are off	4	011	$-V_S$	0	V_S
$S_5, S_6,$ and S_4 are on and $S_2, S_3,$ and S_1 are off	5	001	0	$-V_S$	V_S
$S_6, S_1,$ and S_5 are on and $S_3, S_4,$ and S_2 are off	6	101	V_S	$-V_S$	0
$S_1, S_3,$ and S_5 are on and $S_4, S_6,$ and S_2 are off	7	111	0	0	0
$S_4, S_6,$ and S_2 are on and $S_1, S_3,$ and S_5 are off	8	000	0	0	0

Mode 2 Operation

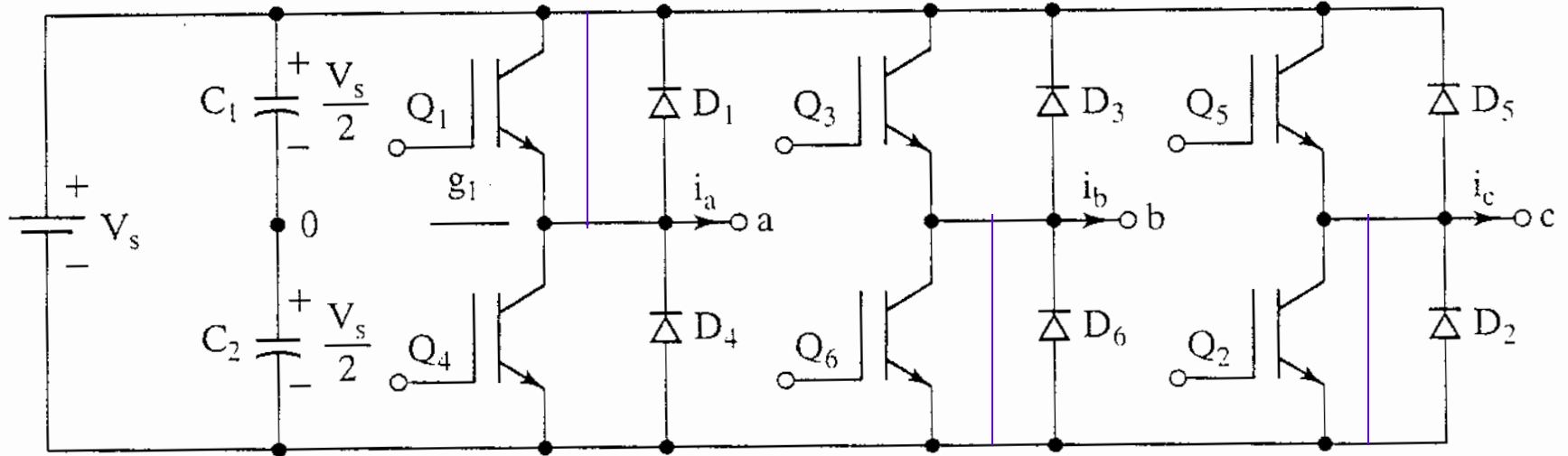

Mode 2 Operation

$$\frac{\pi}{3} \leq \omega t \leq \frac{2\pi}{3}$$

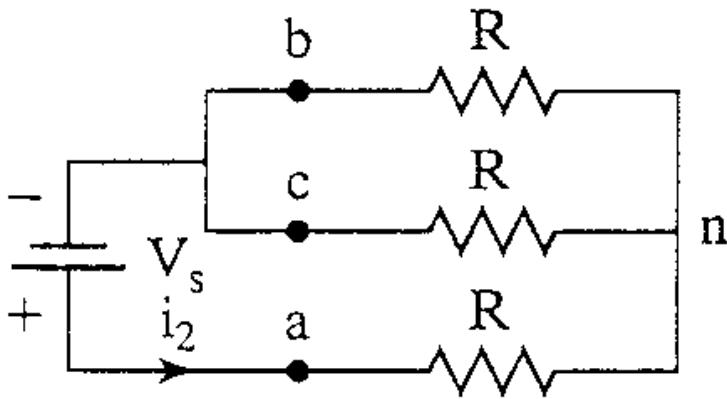

Q_1, Q_2, Q_6 conduct

$$R_{eq} = R + \frac{R}{2} = \frac{3R}{2}$$

$$i_2 = \frac{V_s}{R_{eq}} = \frac{2V_s}{3R}$$

$$v_{an} = i_2 R = \frac{2V_s}{3}$$

$$v_{bn} = v_{cn} = \frac{-i_2 R}{2} = \frac{-V_s}{3}$$

Summary Table

TABLE 6.2 Switch States for Three-Phase Voltage-Source Inverter (VSI)

State	State No.	Switch States	v_{ab}	v_{bc}	v_{ca}
$S_1, S_2,$ and S_6 are on and $S_4, S_5,$ and S_3 are off	1	100	V_S	0	$-V_S$
$S_2, S_3,$ and S_1 are on and $S_5, S_6,$ and S_4 are off	2	110	0	V_S	$-V_S$
$S_3, S_4,$ and S_2 are on and $S_6, S_1,$ and S_5 are off	3	010	$-V_S$	V_S	0
$S_4, S_5,$ and S_3 are on and $S_1, S_2,$ and S_6 are off	4	011	$-V_S$	0	V_S
$S_5, S_6,$ and S_4 are on and $S_2, S_3,$ and S_1 are off	5	001	0	$-V_S$	V_S
$S_6, S_1,$ and S_5 are on and $S_3, S_4,$ and S_2 are off	6	101	V_S	$-V_S$	0
$S_1, S_3,$ and S_5 are on and $S_4, S_6,$ and S_2 are off	7	111	0	0	0
$S_4, S_6,$ and S_2 are on and $S_1, S_3,$ and S_5 are off	8	000	0	0	0

Mode 3 Operation

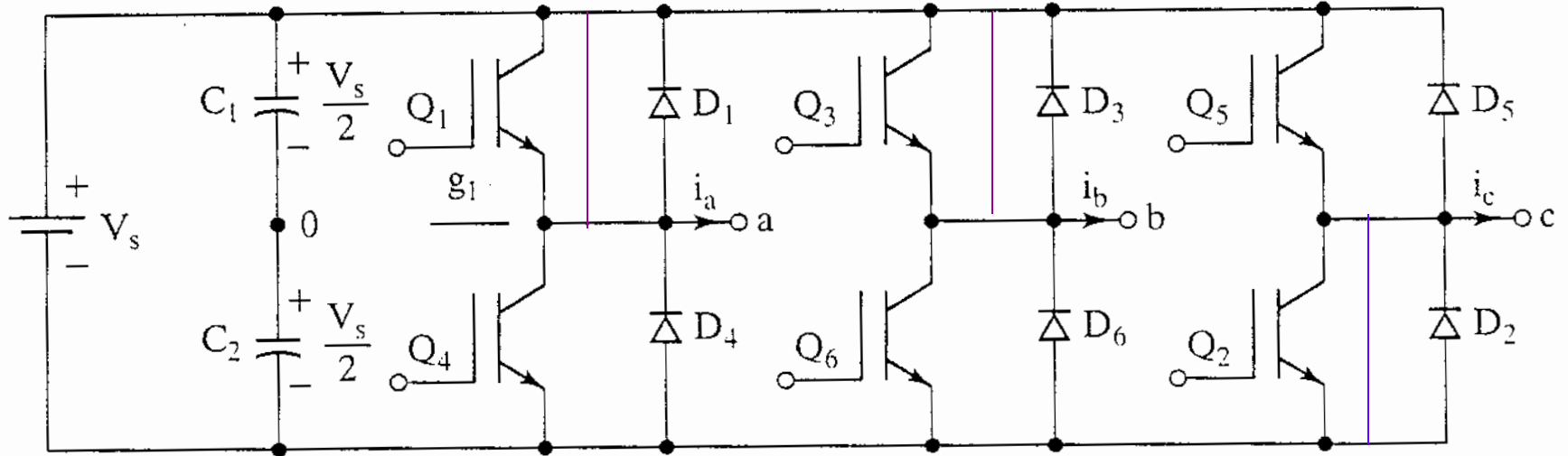

Mode 3 Operation

$$\frac{2\pi}{3} \leq \omega t \leq \pi$$

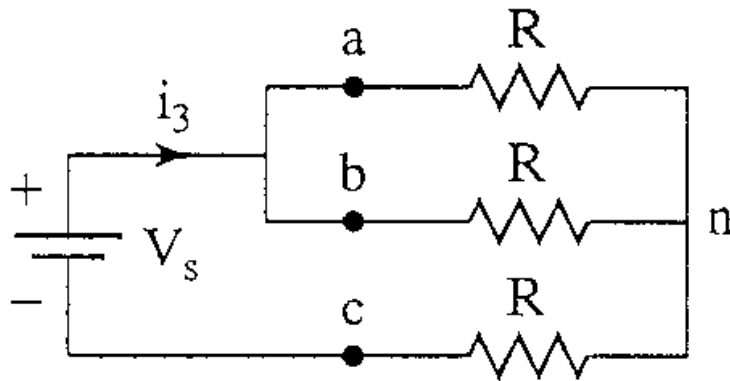

Q_1, Q_2, Q_3 conduct

$$R_{eq} = R + \frac{R}{2} = \frac{3R}{2}$$

$$i_3 = \frac{V_s}{R_{eq}} = \frac{2V_s}{3R}$$

$$v_{an} = v_{bn} = \frac{i_3}{2}$$

$$v_{cn} = i_3 R = \frac{-2V_s}{3}$$

Phase Voltages for 180° Conduction

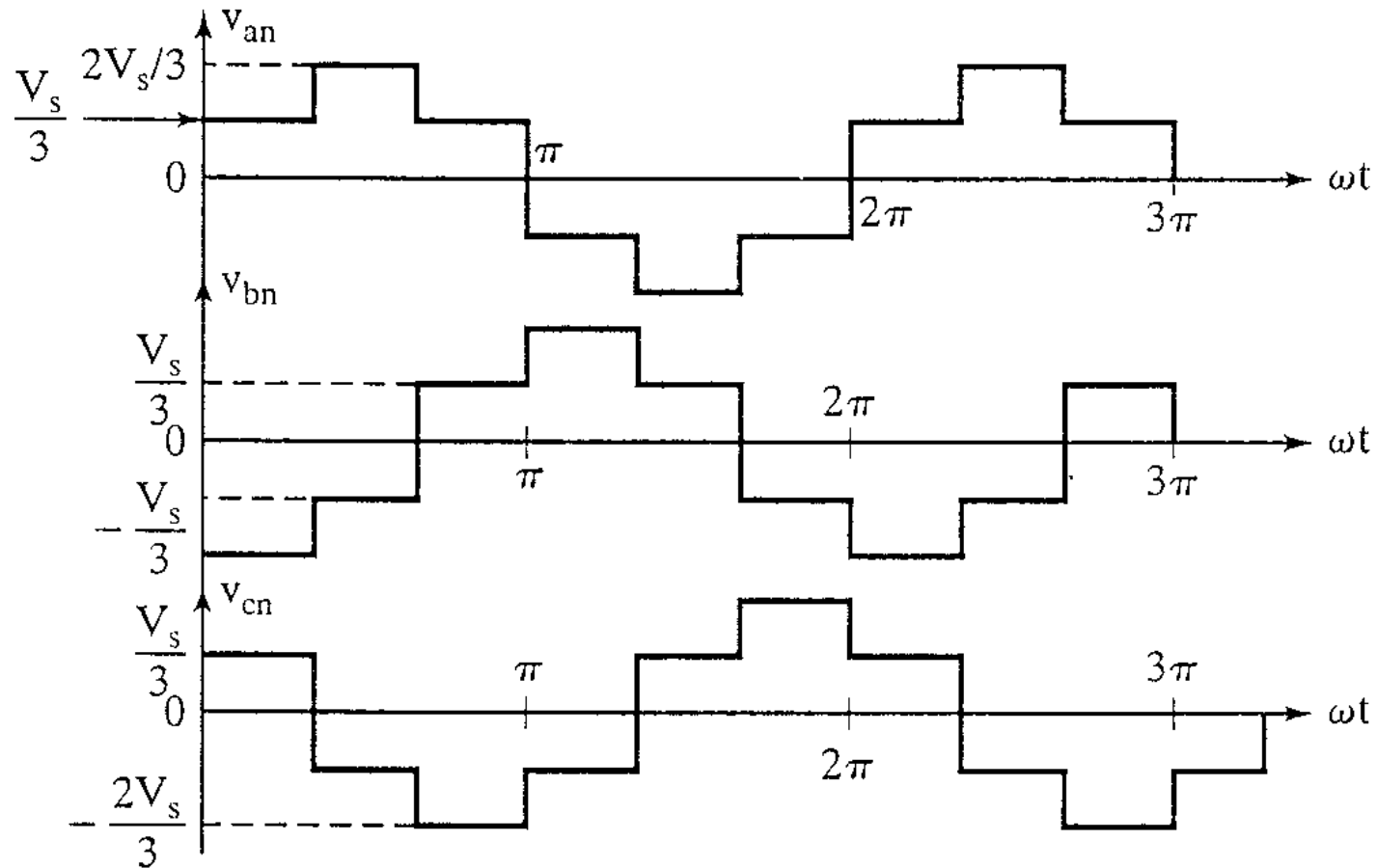

Fourier Series for Line-to-Line Voltages

$$v_{ab} = \frac{a_o}{2} + \sum_{n=1}^{\infty} (a_n \cos(n\omega t) + b_n \sin(n\omega t))$$

$$b_n = \frac{1}{\pi} \left[\int_{-\frac{5\pi}{6}}^{\frac{5\pi}{6}} -V_s d(\omega t) + \int_{\frac{\pi}{6}}^{\frac{5\pi}{6}} V_s d(\omega t) \right]$$

$$b_n = \frac{4V_s}{n\pi} \sin\left(\frac{n\pi}{2}\right) \sin\left(\frac{n\pi}{3}\right)$$

$$v_{ab} = \sum_{n=1,3,5,\dots}^{\infty} \frac{4V_s}{n\pi} \sin \frac{n\pi}{3} \sin n\left(\omega t + \frac{\pi}{6}\right)$$

For the other Line-to-Line Voltages

$$v_{bc} = \sum_{n=1,3,5,\dots}^{\infty} \frac{4V_s}{n\pi} \sin \frac{n\pi}{3} \sin n\left(\omega t - \frac{\pi}{2}\right)$$

$$v_{ca} = \sum_{n=1,3,5,\dots}^{\infty} \frac{4V_s}{n\pi} \sin \frac{n\pi}{3} \sin n\left(\omega t - \frac{7\pi}{6}\right)$$

Line-to-Line rms Voltage

$$V_L = \left[\frac{2}{2\pi} \int_0^{\frac{2\pi}{3}} V_s^2 d(\omega t) \right]^{\frac{1}{2}}$$

$$V_L = \sqrt{\frac{2}{3}} V_s = 0.8165 V_s$$

rms value of the nth Component

$$V_{Ln} = \frac{4V_s}{\sqrt{2n\pi}} \sin \frac{n\pi}{3}$$

$n = 1$ Fundamental Component

$$V_{L1} = \frac{4V_s \sin 60^\circ}{\sqrt{2\pi}} = 0.7797V_s$$

Line-to-Neutral Voltages

$$V_p = \frac{V_L}{\sqrt{3}} = \frac{\sqrt{2}V_s}{3} = 0.4714V_s$$

Phase Voltages (Y-connected load)

$$v_{aN} = \sum_{n=1,3,5,\dots}^{\infty} \frac{4V_s}{\sqrt{3n\pi}} \sin\left(\frac{n\pi}{3}\right) \sin(n\omega t)$$

$$v_{bN} = \sum_{n=1,3,5,\dots}^{\infty} \frac{4V_s}{\sqrt{3n\pi}} \sin\left(\frac{n\pi}{3}\right) \sin n\left(\omega t - \frac{2\pi}{3}\right)$$

$$v_{cN} = \sum_{n=1,3,5,\dots}^{\infty} \frac{4V_s}{\sqrt{3n\pi}} \sin\left(\frac{n\pi}{3}\right) \sin n\left(\omega t - \frac{4\pi}{3}\right)$$

Line Current for an RL load

$$i_a = \sum_{n=1,3,5,\dots}^{\infty} \left[\frac{4V_s}{\sqrt{3} \left[n\pi \sqrt{R^2 + (n\omega L)^2} \right]} \sin \frac{n\pi}{3} \right] \sin(n\omega t - \theta_n)$$

$$\theta_n = \tan^{-1} \left(\frac{n\omega L}{R} \right)$$

DC Supply Current

$$v_s i_s = v_{ab}(t) i_a(t) + v_{bc}(t) i_b(t) + v_{ca}(t) i_c(t)$$

....

$$I_s = 3 \frac{V_{o1}}{V_s} I_o \cos(\theta_1)$$

$$I_s = \sqrt{3} \frac{V_{o1}}{V_s} I_L \cos(\theta_1)$$

$I_L = \sqrt{3} I_o$ is the rms load line current

V_{o1} = fundamental rms output line voltage

I_o is the rms load phase current

θ_1 = the load impedance angle at the fundamental frequency

Three-Phase Inverter with RL Load

