

Decimal or Decade Counter

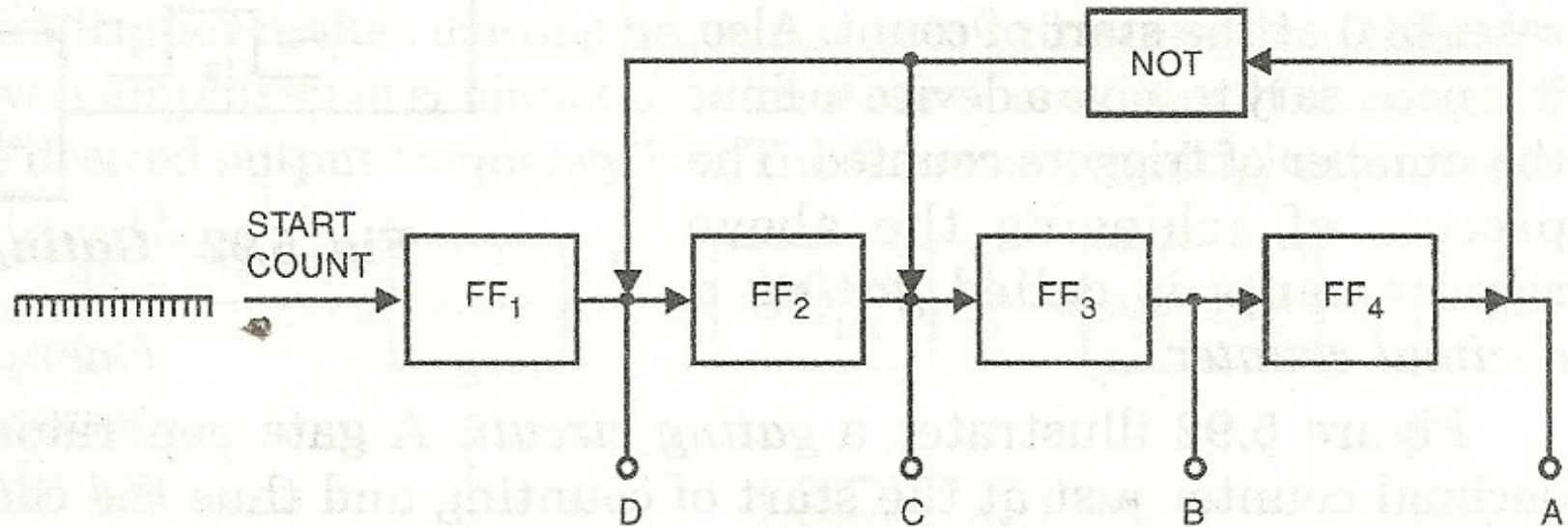

Fig. *Block Diagram of a Decimal Counter*

Decimal or Decade Counter

TABLE Truth Table for Decade Counter

<i>Number of Triggers</i>	<i>A</i>	<i>B</i>	<i>C</i>	<i>D</i>
0	0	0	0	0
1	0	0	0	1
2	0	0	1	0
3	0	0	1	1
4	0	1	0	0
5	0	1	0	1
6	0	1	1	0
7	0	1	1	1
8	1	1	1	0
9	1	1	1	1
10	0	0	0	0

Gating a Decimal Counter

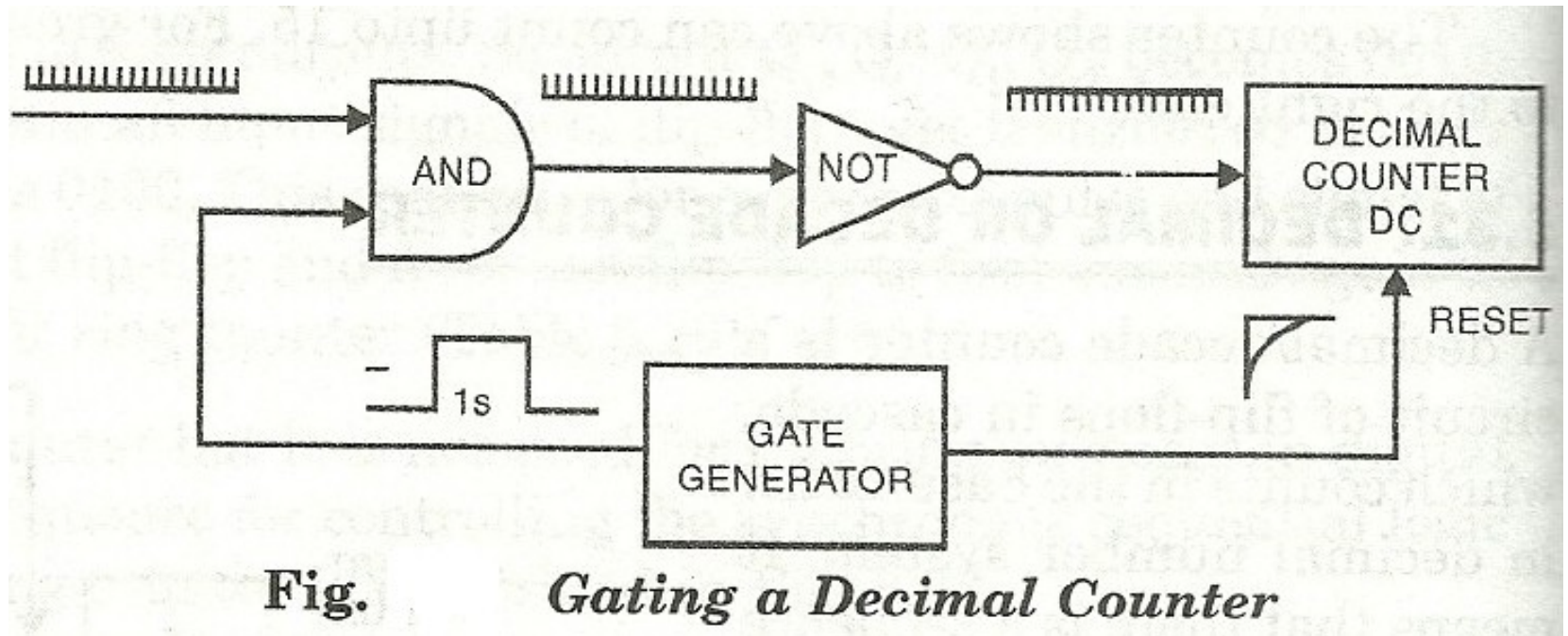

Universal Counter

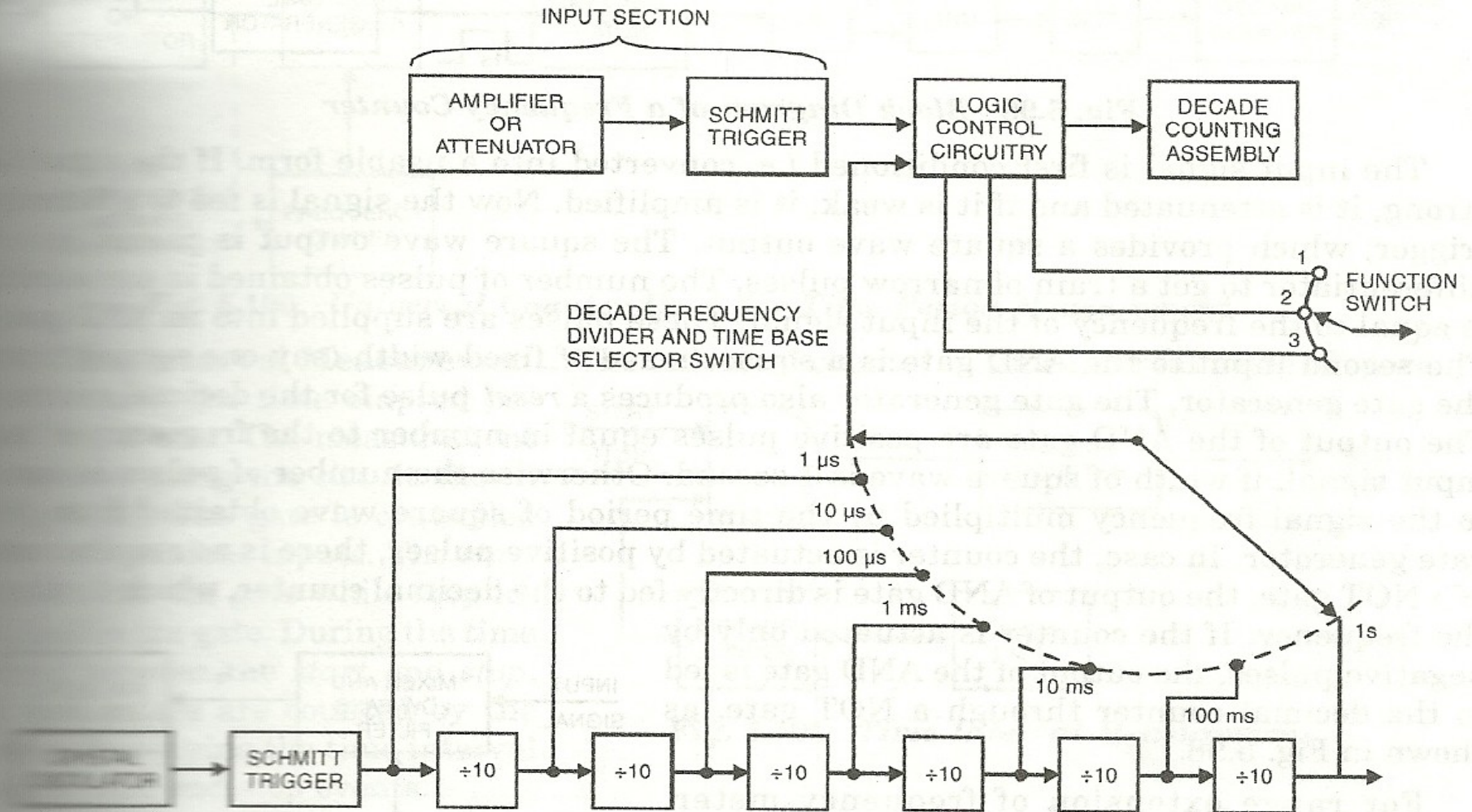

Fig. . Universal Counter

Universal Counter

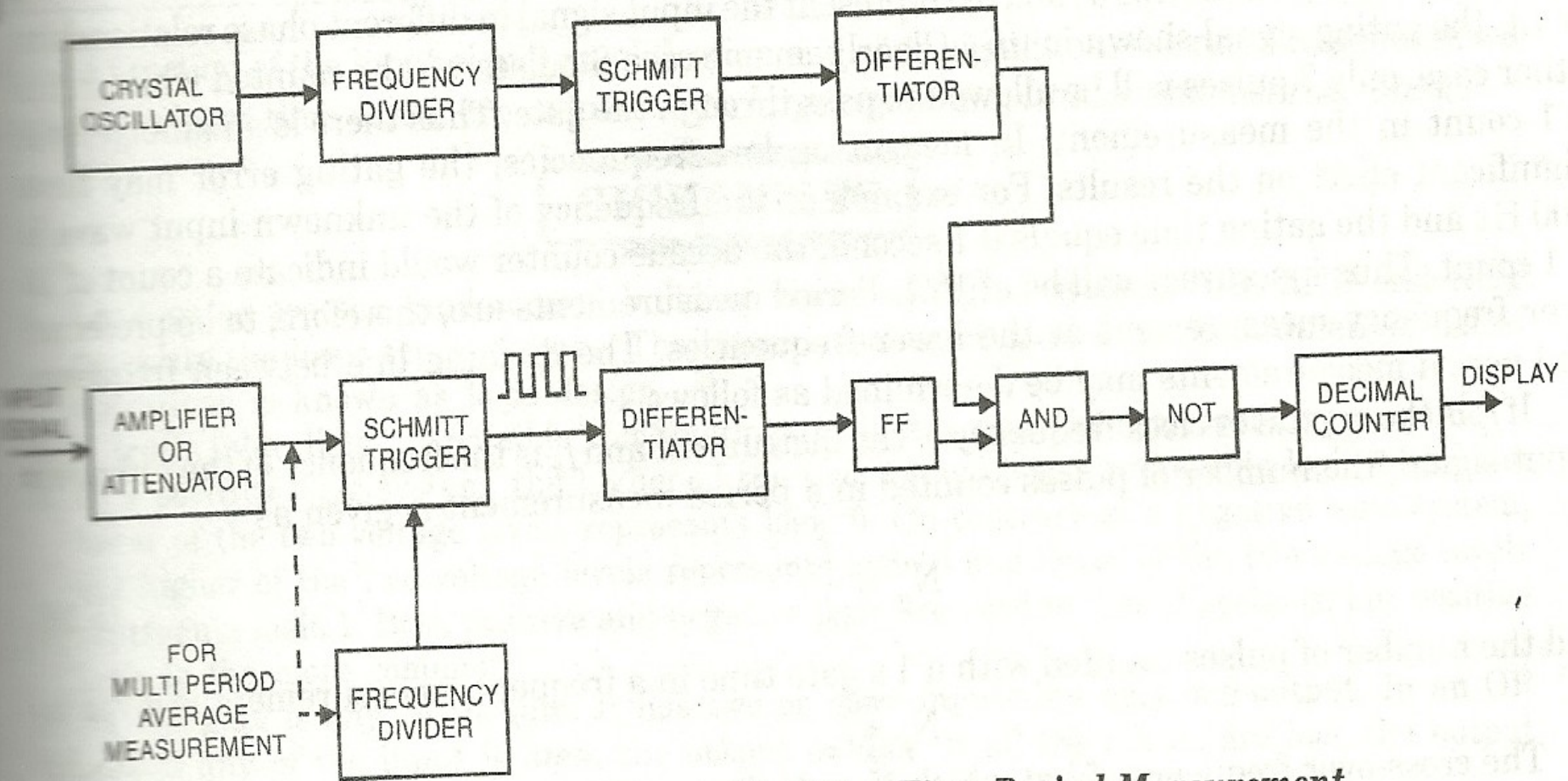

Fig.

Universal Counter Used For Time Period Measurement

Universal Counter

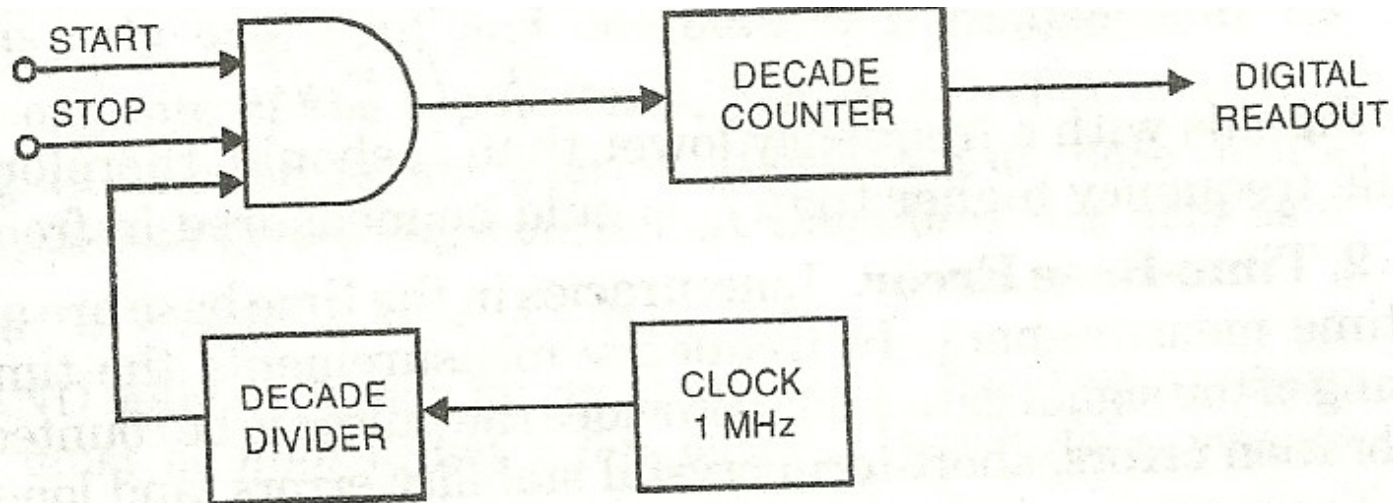

Fig. 1.1 Time Interval Measurement

Universal Counter

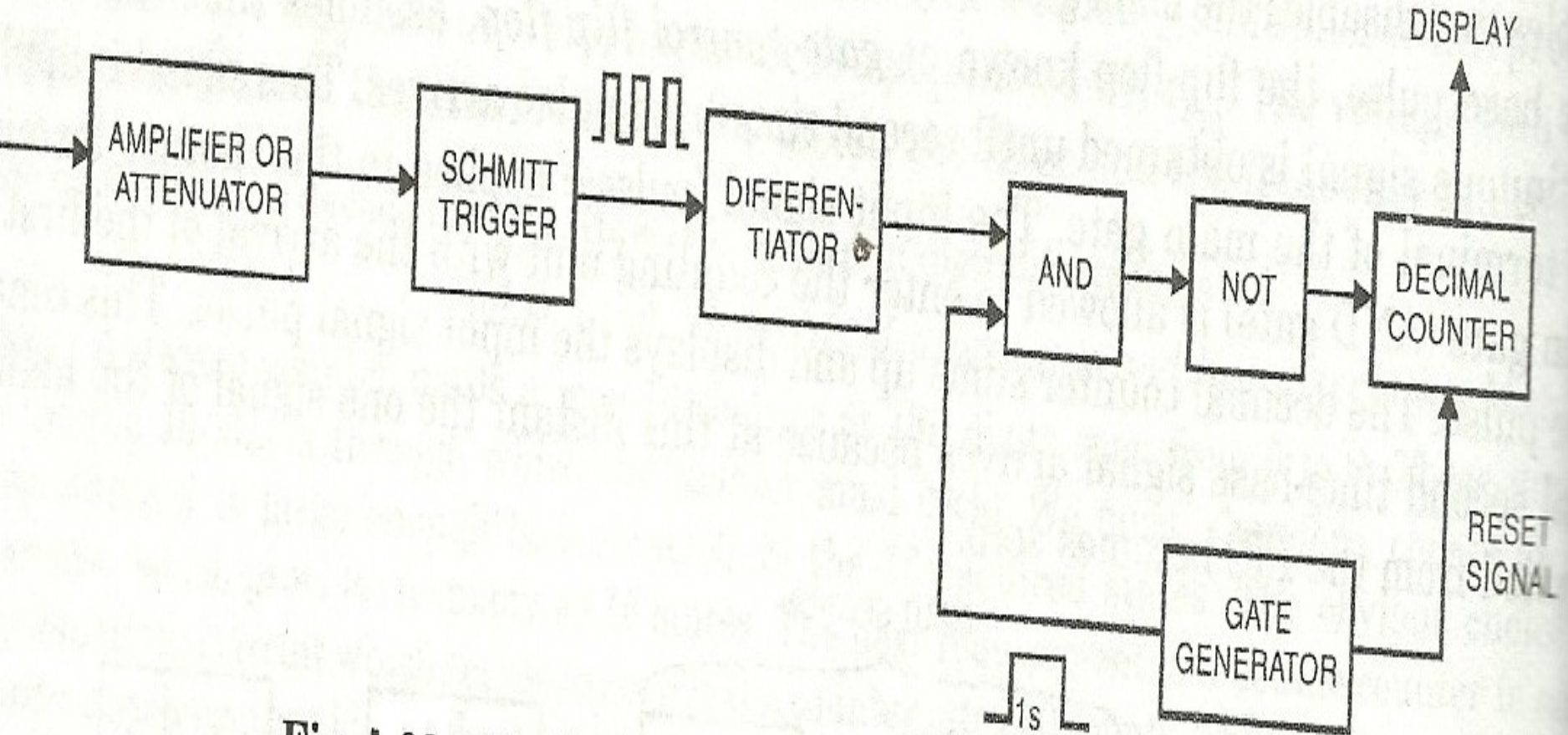

Fig. 5.5 Block Diagram of a Frequency Counter

The input signal is first