

Analog Electronic Circuits

Code: EE-305-F

Text Book:

1. Agarwal : Foundations and electronics and digital electronics, Elsevier
2. Integrated Electronics: Millman & Halkias, TMH
3. Microelectronic Circuits: Sedra Smith

Reference Books:

1. Operational Amplifiers: Gayakwad
2. Electronic Circuit analysis and design (2nd edition): D.A. Neuman, TMH

Section -C

Operational Amplifier

INTRODUCTION

- Usually Called Op Amps
- An amplifier is a device that accepts a varying input signal and produces a similar output signal with a larger amplitude.
- Usually connected so part of the output is fed back to the input. (Feedback Loop)
- Most Op Amps behave like voltage amplifiers. They take an input voltage and output a scaled version.
- They are the basic components used to build analog circuits.
- The name “operational amplifier” comes from the fact that they were originally used to perform mathematical operations such as integration and differentiation.

➤ We can say:

Operational amplifier is a direct coupled high gain amplifier to which feedback is added to control its overall response characteristic. It is used to perform wide variety of linear and non linear function and is often referred to as basic linear integrated circuit or more accurately analog integrated circuit.

Block Diagram of typical Op-amp

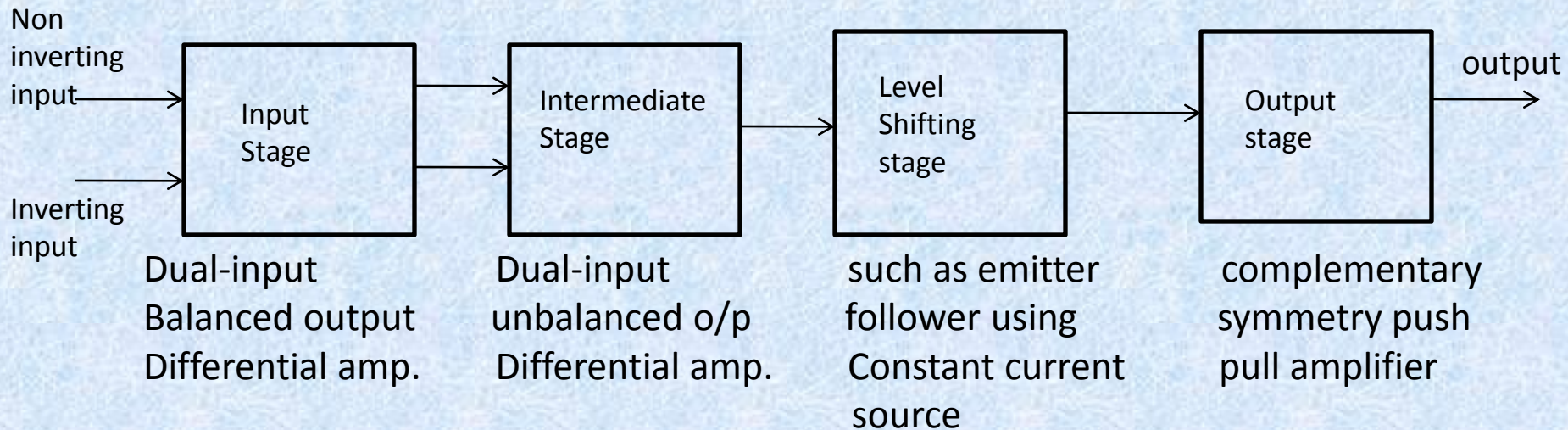

Schematic Symbol

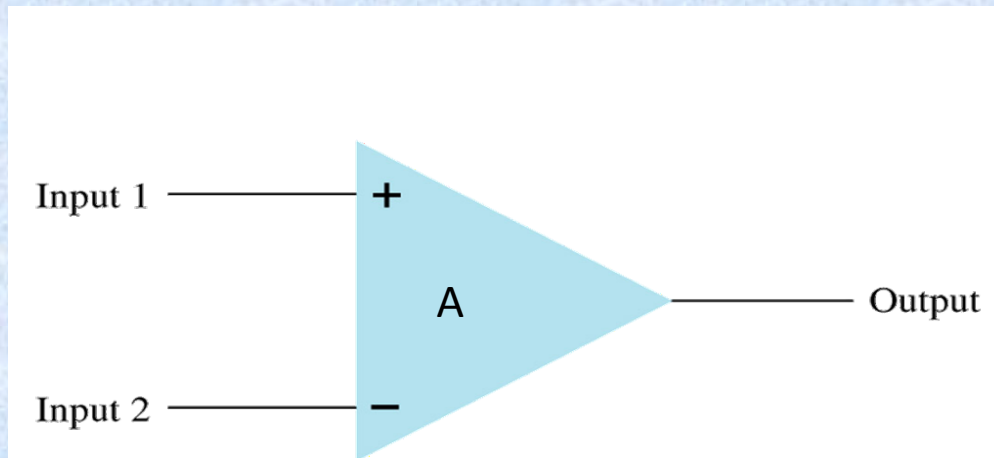

Input1- non inverting input (volts)

Input2- inverting input (volts)

Output- output voltage (volts)

A-Large signal voltage gain

$$\text{Output} = A (\text{input1} - \text{input2})$$

Op-amp has two inputs that connect to two terminals and one output

Equivalent circuit of an op-amp

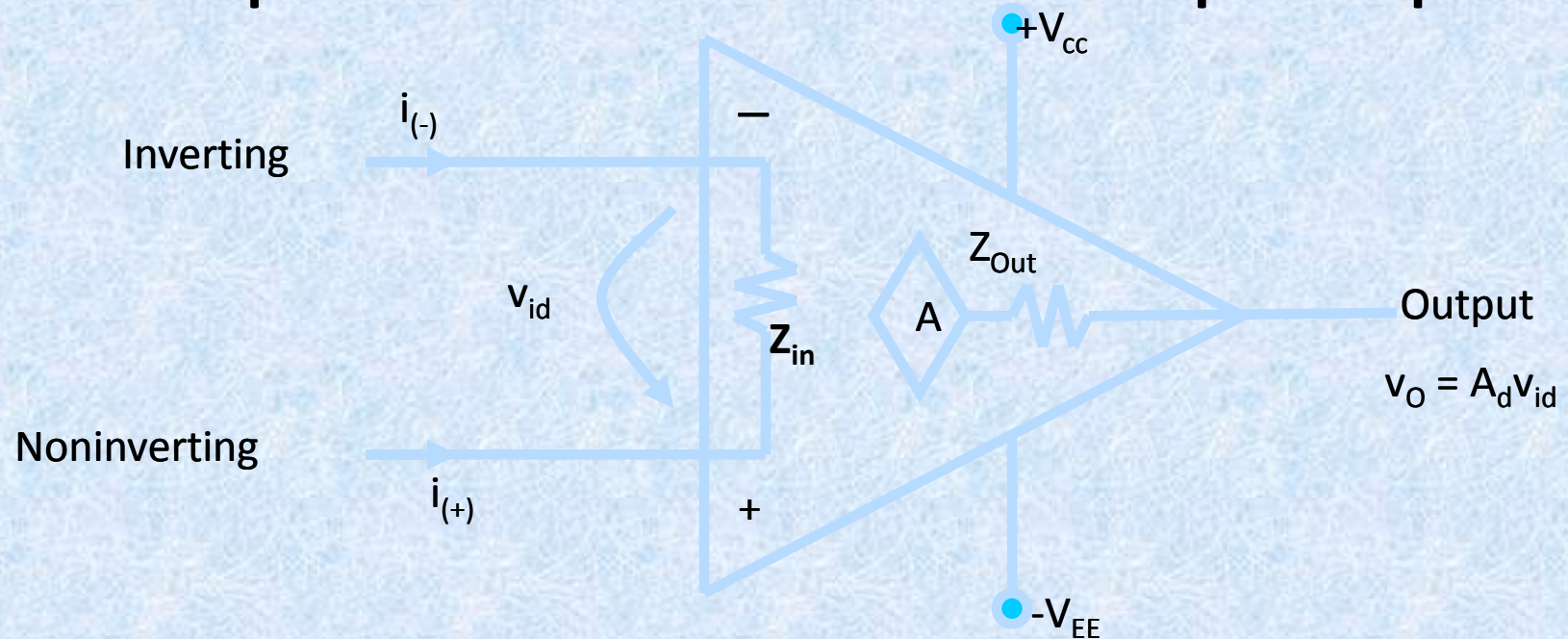

- $i_{(+)}$, $i_{(-)}$: Currents into the amplifier on the inverting and noninverting lines respectively
- v_{id} : The input voltage from inverting to non-inverting inputs
- $+V_{CC}$, $-V_{EE}$: DC source voltages, usually +15V and -15V
- Z_{in} : The input resistance, ideally infinity
- A : The gain of the amplifier. Ideally very high, in the 1×10^{10} range.
- Z_{Out} : The output resistance, ideally zero
- v_O : The output voltage; $v_O = A_{OL} v_{id}$ where A_{OL} is the open-loop voltage gain
- V_{id} : Difference input voltage

Schematic diagram of 741 IC opamp

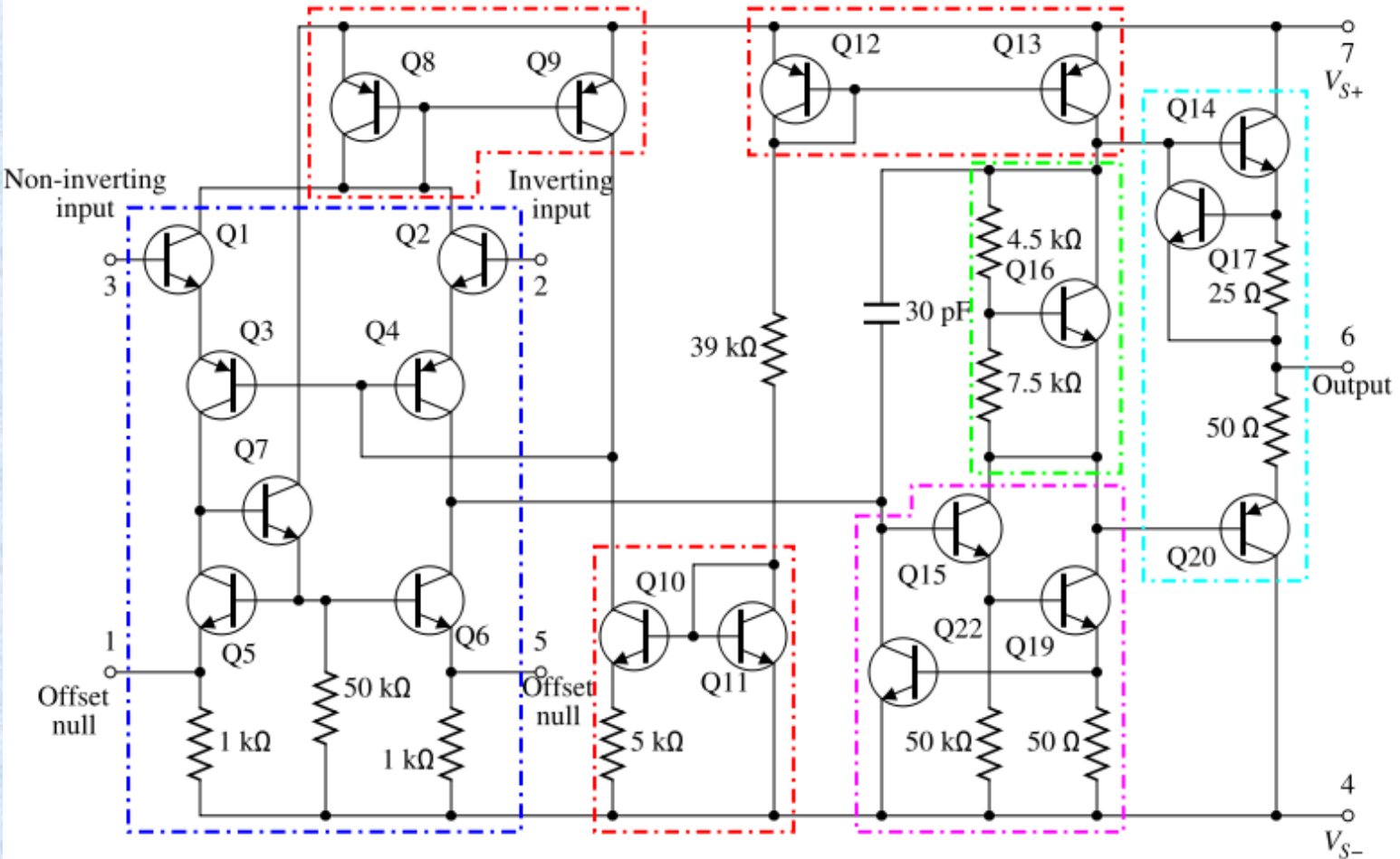

Dual –in-line package

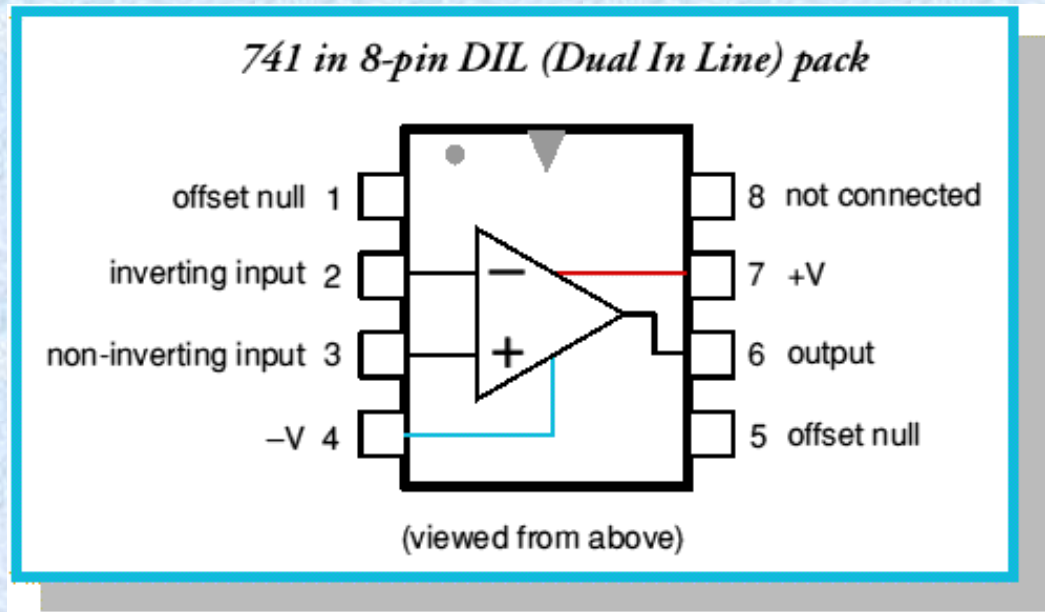

Since the op-amp is the differential type, input offset voltage must be controlled so as to minimize offset. Offset voltage is nulled by application of a voltage of opposite polarity to the offset. An offset null-adjustment potentiometer may be used to compensate for offset voltage. The null-offset potentiometer also compensates for irregularities in the operational amplifier manufacturing process which may cause an offset.

Ideal Voltage transfer curve of op amp

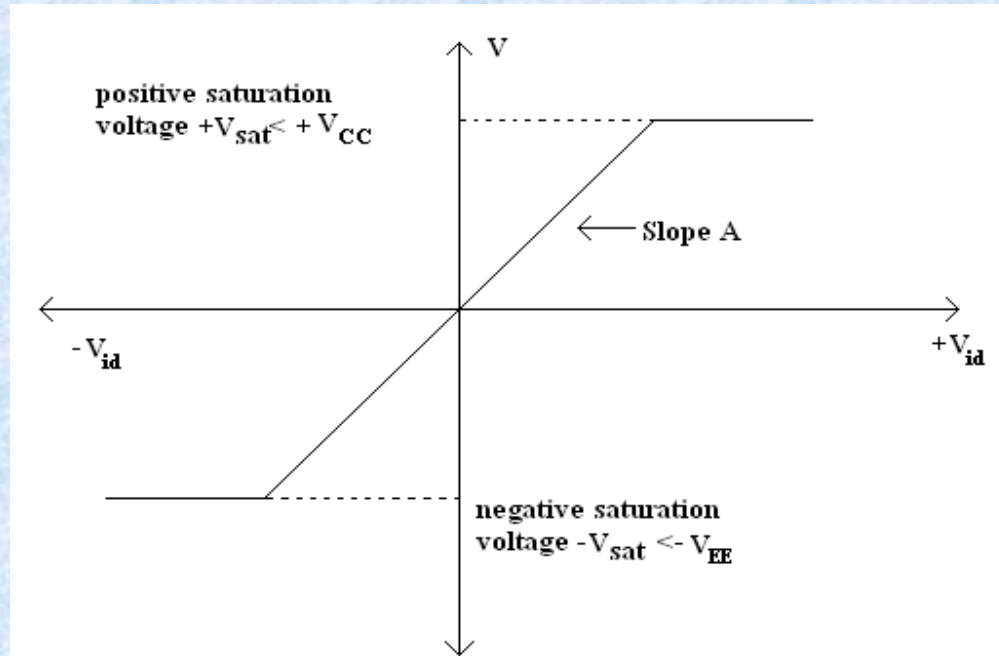

- $v_o = A_{OL}v_{id}$ This is the basic op-amp equation in which the output offset voltage is assumed to be zero.
- The graphic representation of this equation is shown; where the output voltage, v_o is plotted against input difference voltage V_{id} , keeping gain A constant.
- The output voltage cannot exceed the positive and negative saturation voltage.
- The output voltage is directly proportional to the input difference voltage until it reaches the saturation voltages and thereafter the output voltage remains constant.
- This curve is called ideal voltage transfer curve.

Ideal Vs Practical Op-Amp

	Ideal	Practical
Open Loop gain A	∞	10^5
Bandwidth BW	∞	10-100Hz
Input Impedance Z_{in}	∞	$>1M\Omega$
Output Impedance Z_{out}	0Ω	10-100 Ω
Output Voltage V_{out}	Depends only on $V_d = (V_+ - V_-)$ Differential mode signal	Depends slightly on average input $V_c = (V_+ + V_-)/2$ Common-Mode signal
CMRR	∞	10-100dB

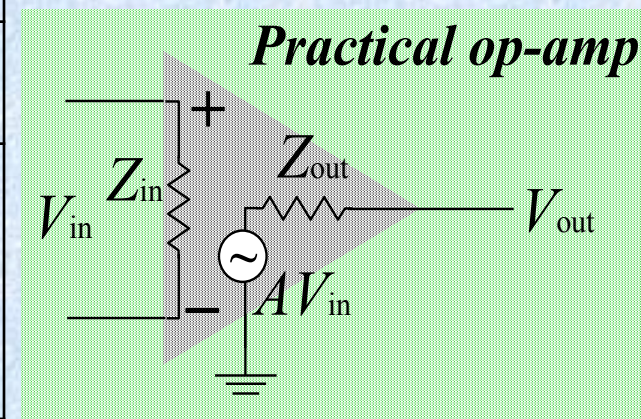
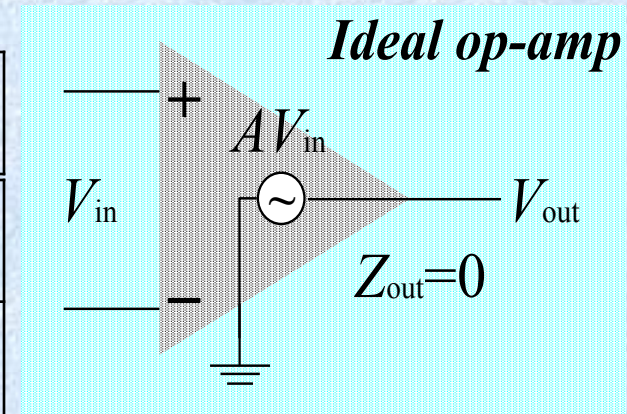

Open loop op-amp configuration

- In case of amplifiers the term open loop indicates that no connection either direct or via another network exists between input and output terminals.
- Output signal is not fed back in any form as part of input signal.
- When connected in open loop configuration, the op-amp simply function as high-gain amplifier. There are 3 open loop op amp configuration:
 - 1) Differential amplifier
 - 2) Inverting amplifier
 - 3) Non inverting amplifier

These configuration are classed according to number of inputs used and the terminal to which input is applied when a single input is used.

The Differential Amplifier

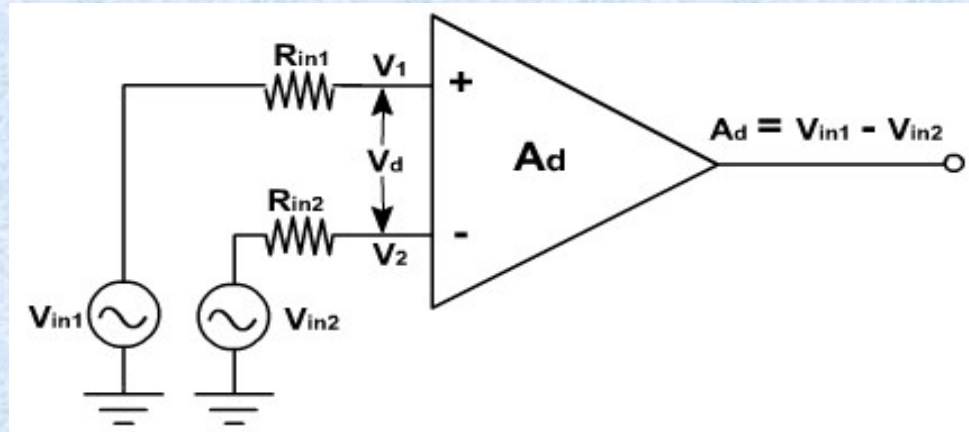

- open loop differential amplifier in which input signals v_{in1} and v_{in2} are applied to the positive and negative input terminals.
- Since the OPAMP amplifies the difference between the two input signals, this configuration is called the differential amplifier.
- The OPAMP amplifies both ac and dc input signals. The source resistance R_{in1} and R_{in2} are normally negligible compared to the input resistance R_i (ideally infinite). Therefore voltage drop across these resistances can be assumed to be zero.
- Therefore
- $v_1 = v_{in1}$ and $v_2 = v_{in2}$.
- $v_o = A_d (v_{in1} - v_{in2})$
- where, A_d is the open loop gain.

The Inverting Amplifier

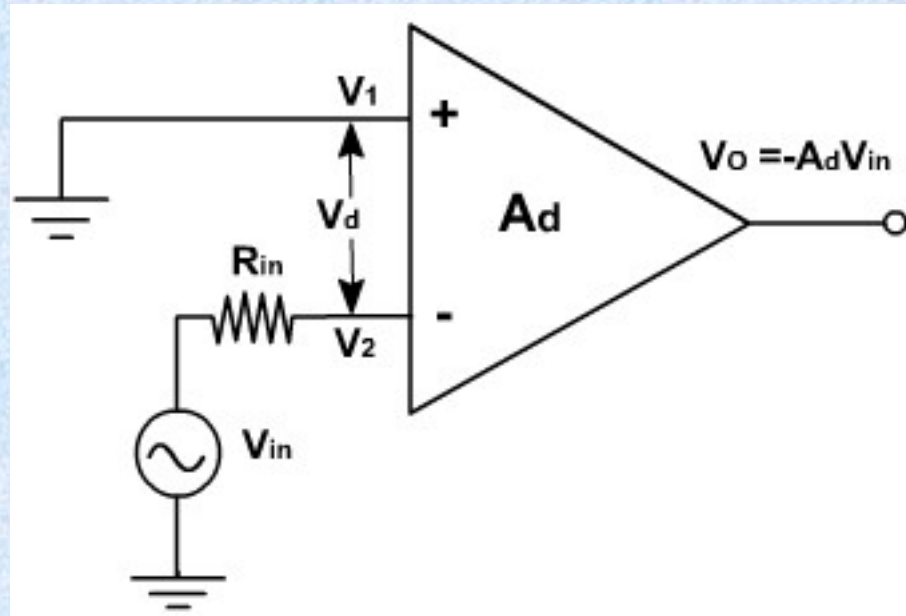

- If the input is applied to only inverting terminal and non-inverting terminal is grounded then it is called inverting amplifier. This configuration is shown in **fig.**
- $v_1 = 0, v_2 = v_{in}$.
- $v_o = -A_d v_{in}$
- The negative sign indicates that the output voltage is out of phase with respect to input 180° or is of opposite polarity. Thus the input signal is amplified and inverted also.

The Non-inverting Amplifier

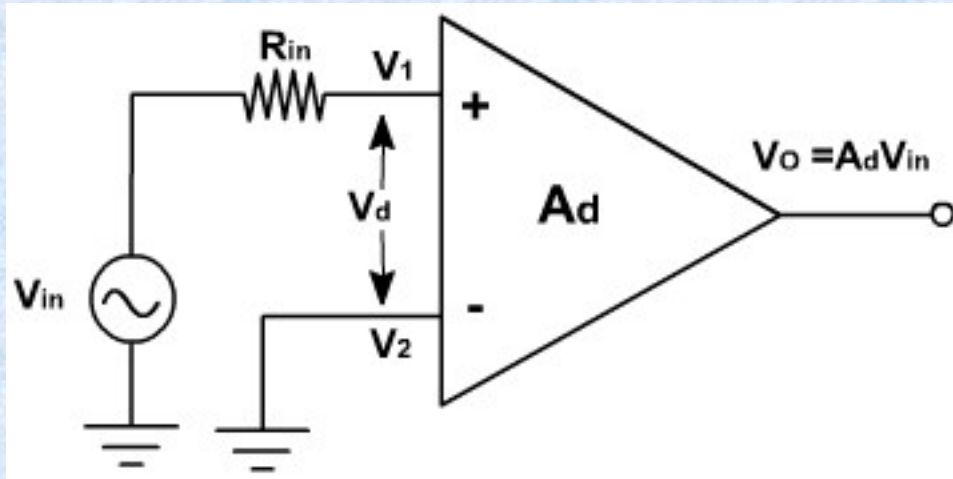

- In this configuration, the input voltage is applied to non-inverting terminals and inverting terminal is ground as shown in **fig**.
- $V_1 = +V_{in}$ $V_2 = 0$
- $V_o = +A_d V_{in}$
- This means that the input voltage is amplified by A_d and there is no phase reversal at the output.
- In all three configurations any input signal slightly greater than zero drive the output to saturation level. This is because of very high gain. Thus when operated in open-loop, the output of the OPAMP is either negative or positive saturation or switches between positive and negative saturation levels. Therefore open loop op-amp is not used in linear applications.

Open loop op amp is not used in linear applications. Why?

- Because open loop gain of op amp is very high, only the smaller signals (on order of microvolt or less) having very low frequency may be amplified accurately without distortion. These small signals are very susceptible to noise and almost impossible to obtain in lab.
- Open loop voltage gain of op amp is not constant and varies with change in temperature and power supply. These variations makes the open loop op amp unsuitable for many linear applications.
- So open loop op amp is impractical in ac applications. For e.g. open loop bandwidth of 741C is approx. 5Hz. In almost all ac applications a bandwidth larger than 5Hz is needed.

So to select as well as control the gain of op amp , add feedback in the circuit ,means output signal is fed back to the input either directly or via another network.

Types of feed back

- **Negative feedback:** If the signal fed back is of opposite polarity or out of phase by 180° (or odd integer multiple of 180°) with respect to input signal, feedback is called negative feedback.
- -ve feedback is also known as **degenerative feedback** because when used it degenerates (reduces) the output voltage amplitude and in turn reduces the voltage gain.

Uses:

- When used in amplifier, -ve feedback stabilizes the gain, increases the bandwidth and changes the input and output resistances, reduced voltage gain, decrease in non linear distortion and reduces the effect of variations in temperature and supply voltages on the output of op-amp.
- **Positive feedback:** If the signal fed back is of the same polarity or in phase with the input signal, the feedback is called positive feedback.
- In + ve feedback the feedback signal aids the input signal, so referred as **regenerative feedback**. +ve feedback is used in oscillator circuits.

- A op amp that uses feedback is called feedback amplifier.
- Feedback forms a close loop between input and output so referred as closed loop amplifier also.
- Feedback amplifier consists of two parts: op-amp and feedback circuit (made up of either passive ,active or combination of both components)
- There are four ways to connect these 2 blocks according to whether the voltage or current is fed back to the input in series or in parallel:-

- | | | |
|---|---|--|
| <ol style="list-style-type: none"> 1) Voltage series feedback 2) Voltage shunt feedback | } | <p>The voltage across RL is input voltage to feedback circuit. Feedback quantity is the output of feedback circuit and proportional to output voltage.</p> |
| <ol style="list-style-type: none"> 3) Current series feedback 4) Current shunt feedback | } | <p>Load current flows into feedback circuit . Output of feedback circuit (either current or voltage) is proportional to load current.</p> |

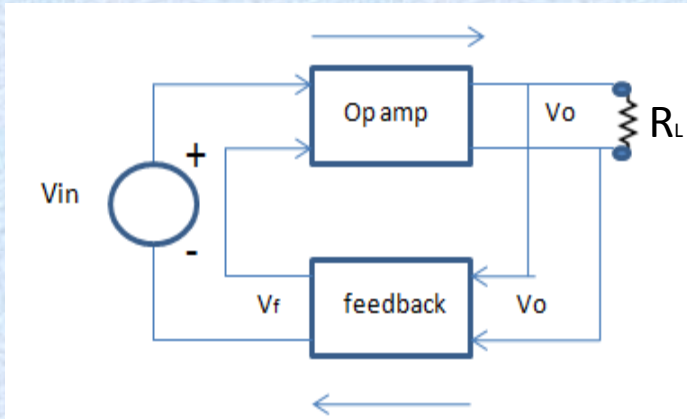

Fig. A voltage-series

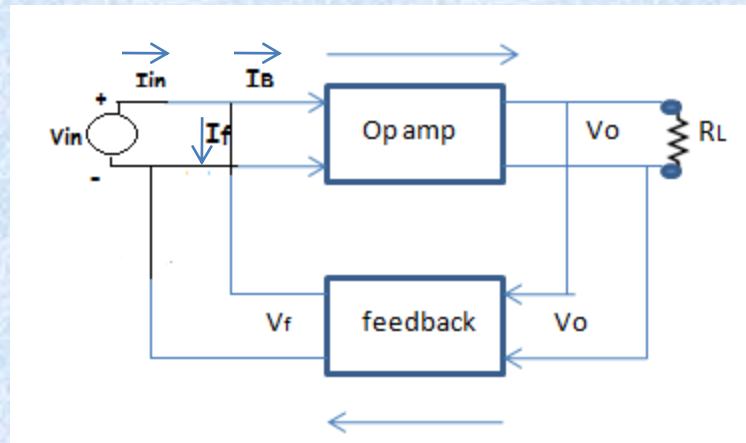

Fig. B voltage-shunt

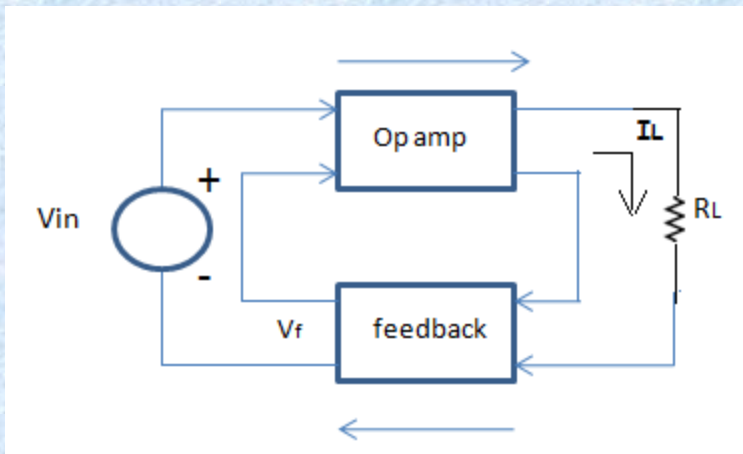

Fig. C current-series

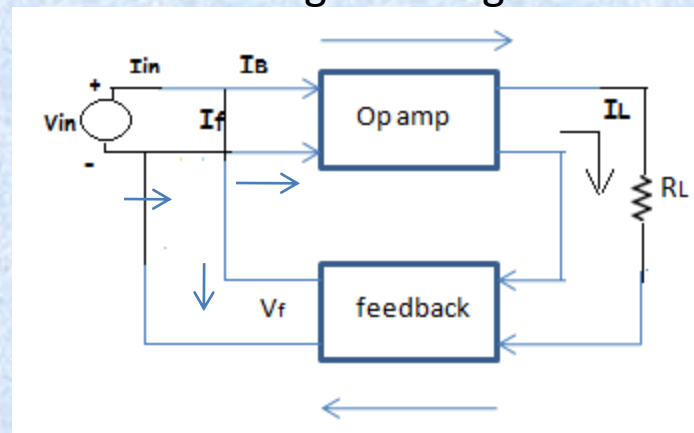
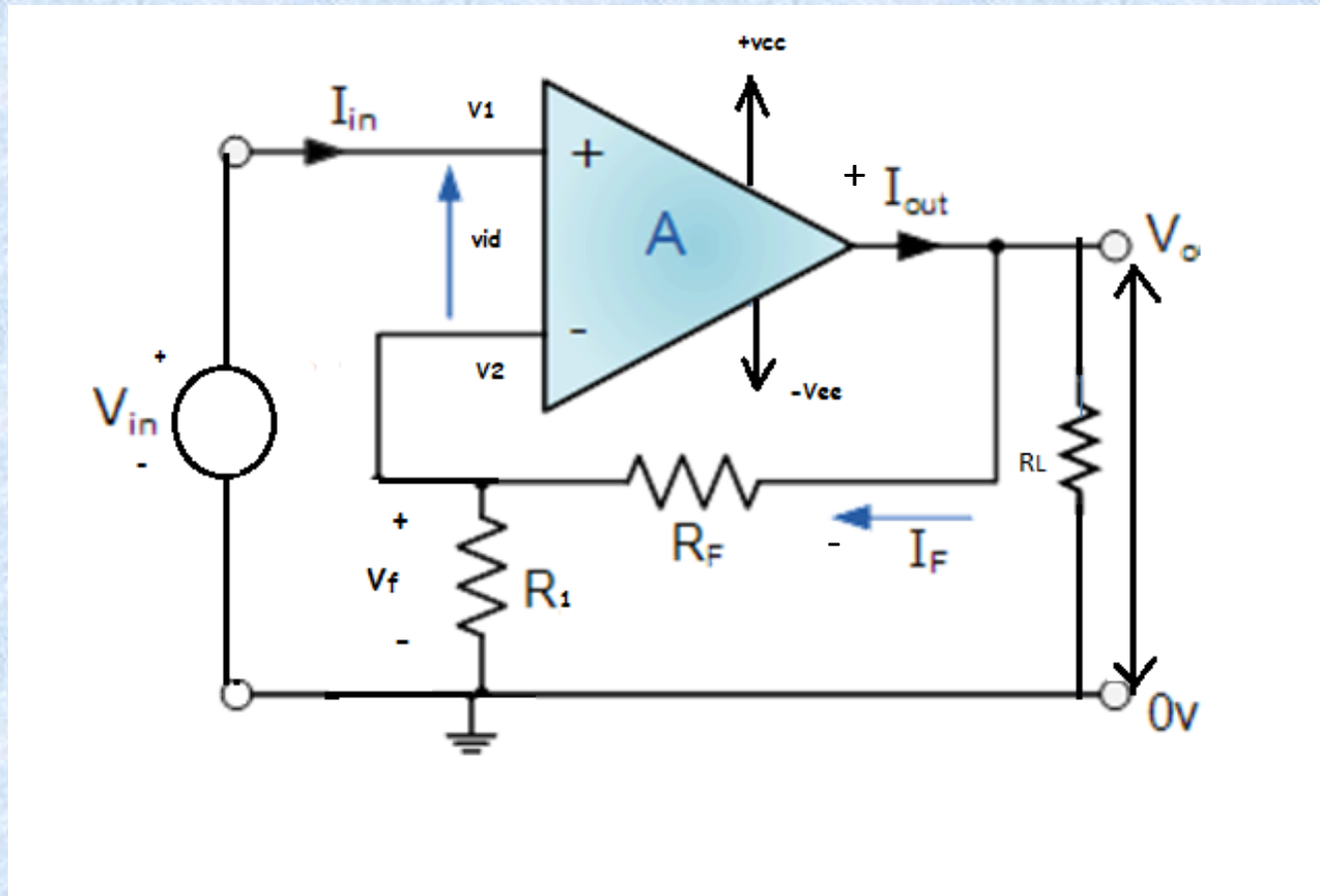

Fig. D current-shunt

Voltage series feedback amplifier or non inverting amplifier with feedback



Calculations

- Negative feedback $v_{id} = V_{in} - V_f$
- Closed loop voltage gain $A_f = A / (1 + AB)$
- Difference input voltage $A_f = 1 + R_f / R_1$
- Bandwidth with feedback $F_f = f_o(1 + AB)$
- Total output offset voltage with feedback =
(Total output offset voltage without feedback) / (1 + AB)

Open loop gain vs. freq .response

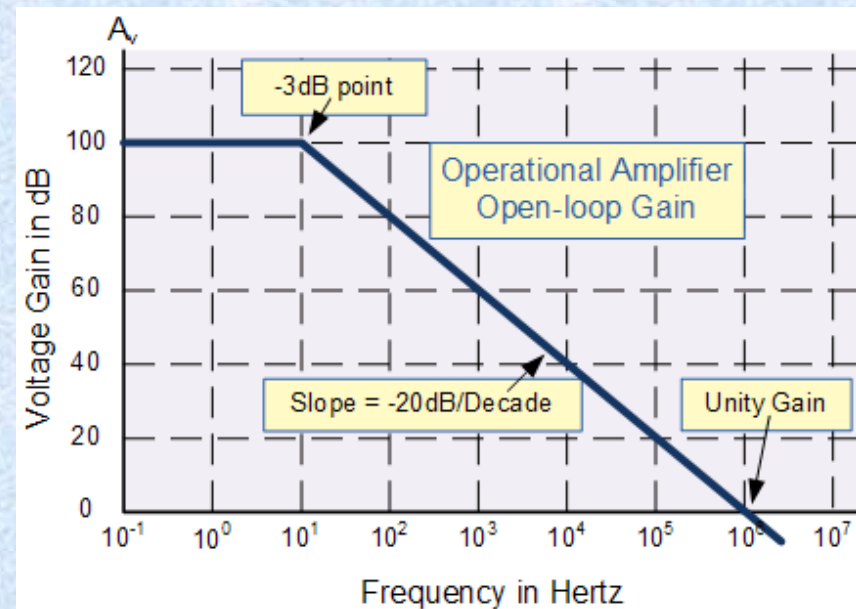

Input and output resistance with feedback

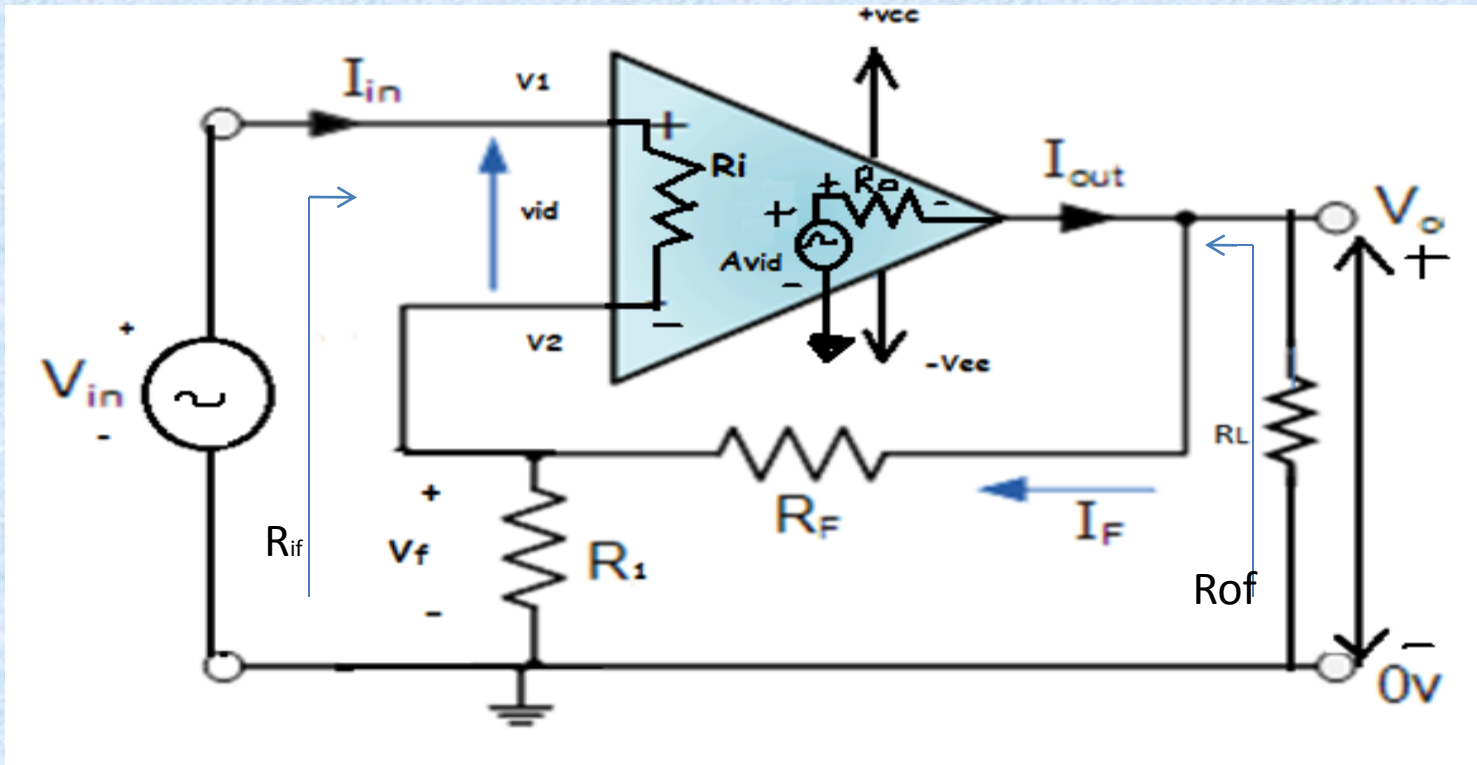

← BACK

Input resistance with feedback $R_{if} = R_i(1 + AB)$

Output Resistance with feedback $R_{of} = R_o / (1 + AB)$

Op-amp Voltage Follower Configuration

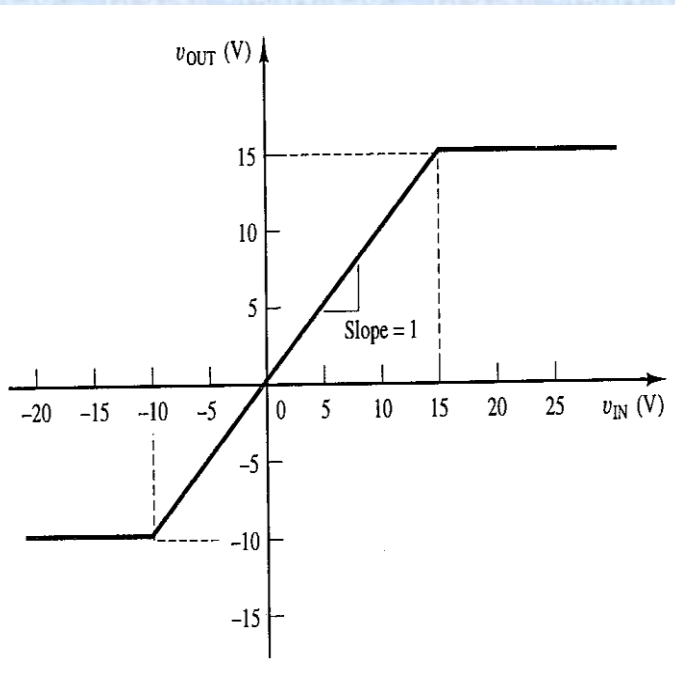
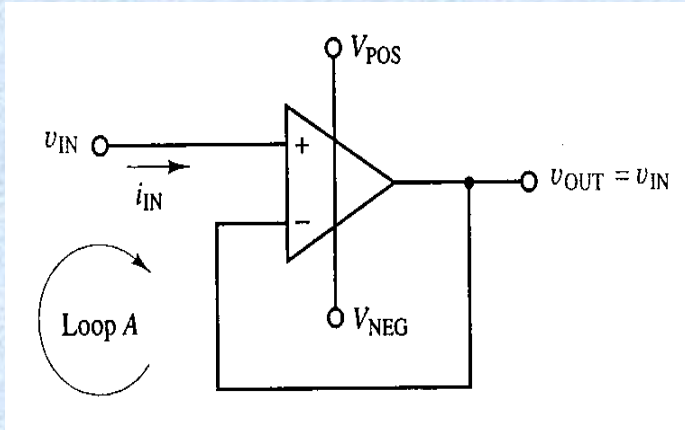

- The lowest gain that can be obtained from a non inverting amplifier with feedback is 1.
- When non inverting amplifier is configured for unity gain , it is called voltage follower because the o/p voltage is equal to and in phase with the input or output follows the input.
- The op-amp configuration shown at left is a voltage-follower often used as a buffer amplifier
 - Output is connected directly to negative input (negative feedback)
 - Since $v_+ = v_- = v_{IN}$, and $v_{OUT} = v_-$, so closed-loop gain $A_o = 1$
 - We can obtain the same result by writing
$$v_{OUT} = A (v_{IN} - v_{OUT}) \quad \text{or}$$
$$v_{OUT}/v_{IN} = A/(1 + A) = 1 \quad \text{for } A \gg 1$$
- A typical voltage-follower transfer curve is shown in the left-bottom figure for the case $V_{POS} = +15\text{V}$ and $V_{NEG} = -10\text{V}$
 - For v_{IN} between -10 and $+15$ volts, $v_{OUT} = v_{IN}$
 - If v_{IN} exceeds $+15\text{V}$, the output saturates at V_{POS}
 - If $v_{IN} < -10\text{V}$, the output saturates at V_{NEG}

Voltage shunt feedback amplifier or inverting amplifier with feedback

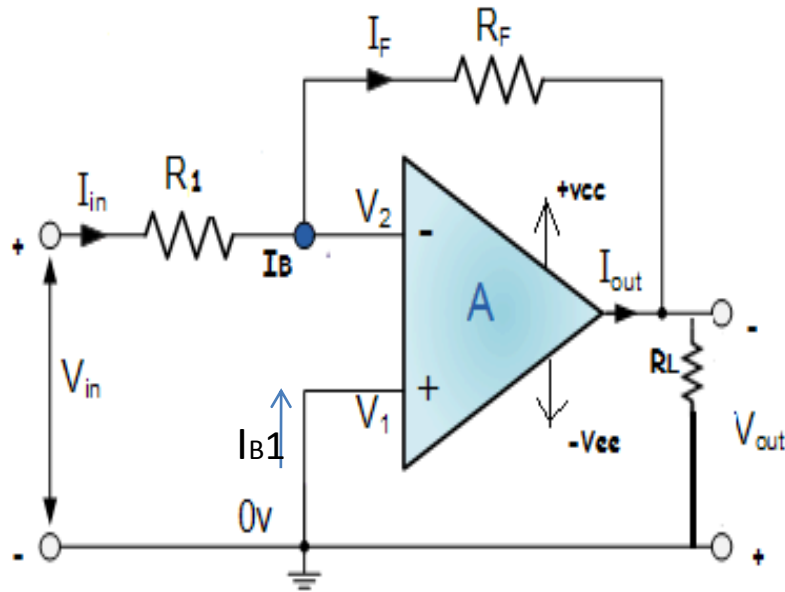

Calculate:
Closed loop voltage gain

$$A_f = -R_f/R_1$$