

Block Diagram Manipulation (reduction)

- We often represent control systems using block diagrams. A block diagram consists of blocks that represent transfer functions of the different variables of interest.
- If a block diagram has many blocks, not all of which are in cascade, then it is useful to have rules for rearranging the diagram such that you end up with only one block.

For example, we would want to transform the following diagram

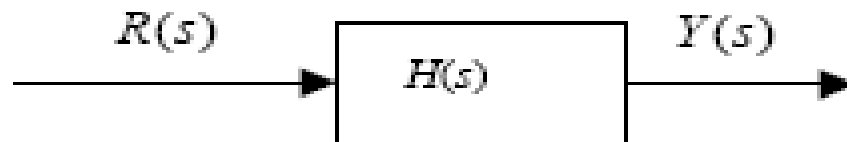
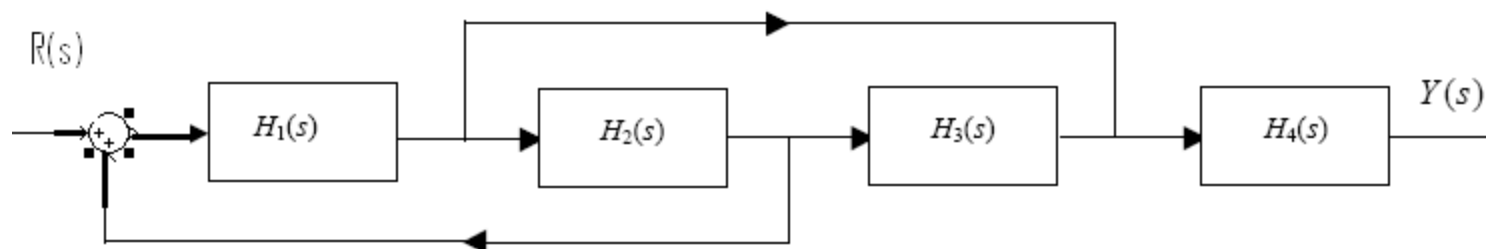

How do we get $H(s)$ from $H_1(s)$, $H_2(s)$, $H_3(s)$, $H_4(s)$?

Block Diagram Transformations

1. Combining blocks in cascade(series)

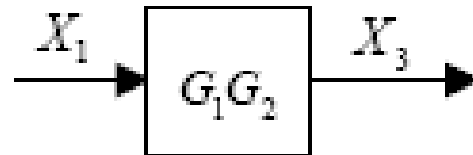
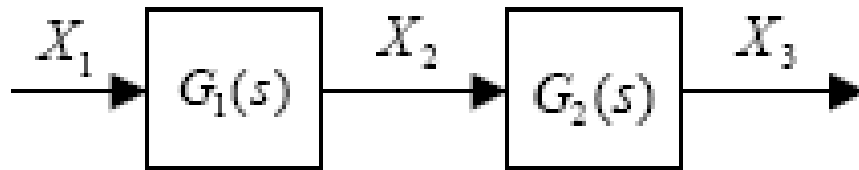

or



2 (Blocks in Parallel)

$$Y = X(G_1 + G_2) = G_1X + G_2X$$

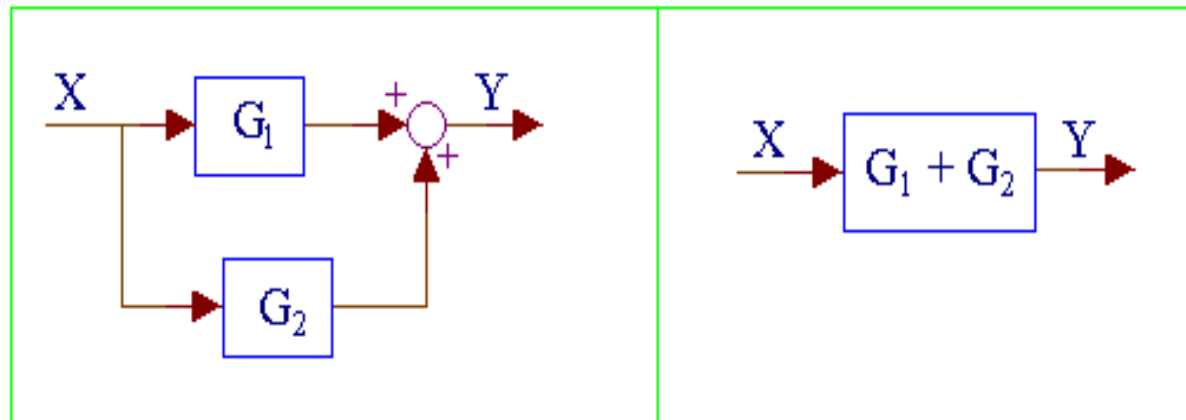

3. Moving a summing point behind a block

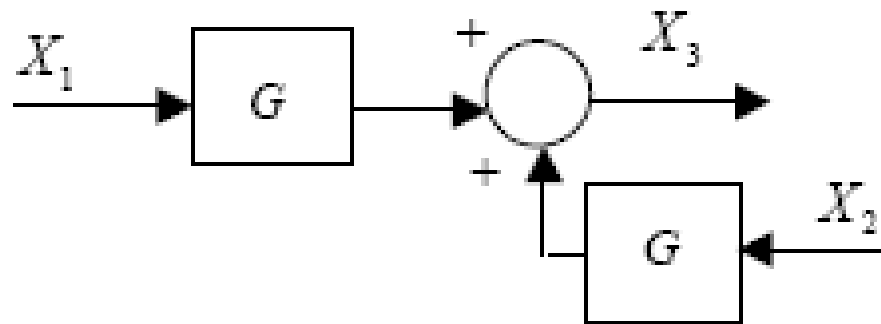
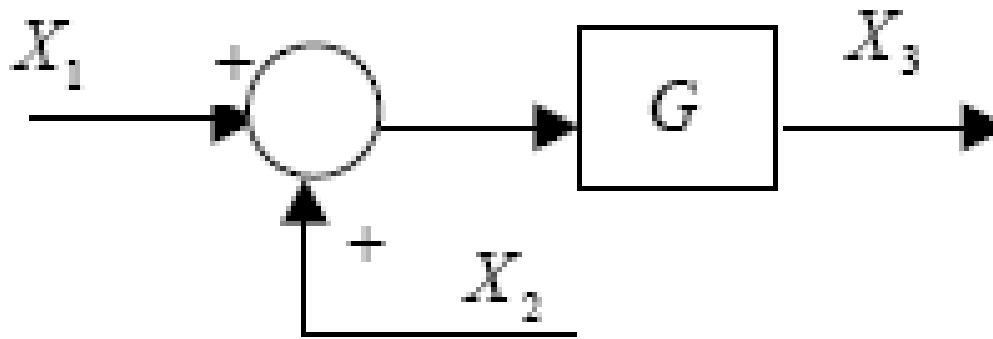

4. Moving a pickoff point ahead of a block

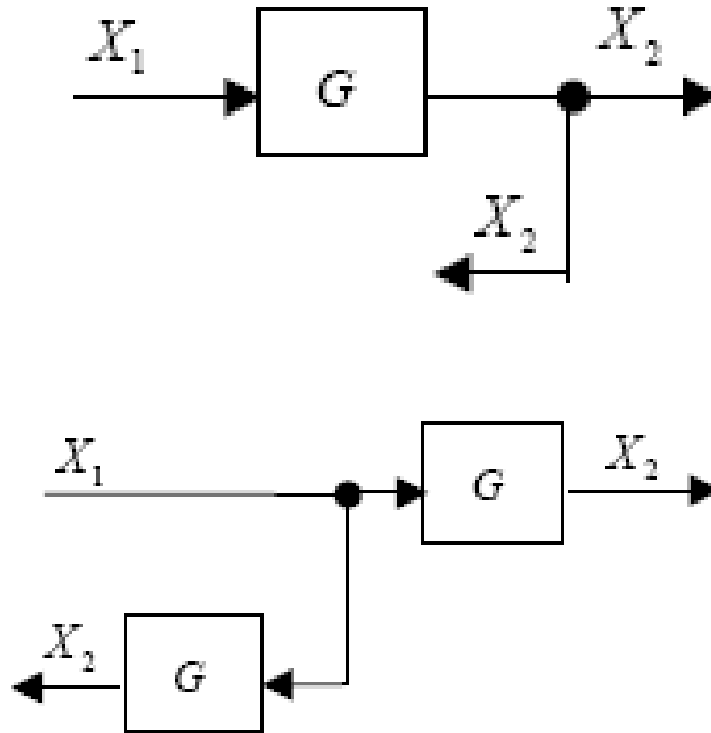

5. Moving a pickoff point behind a block

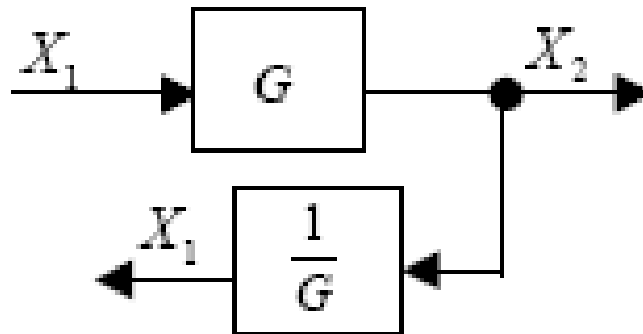
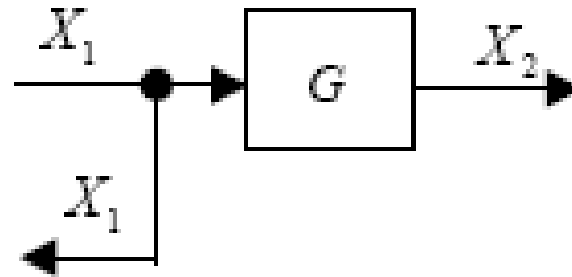

6. Moving a summing point ahead of a block

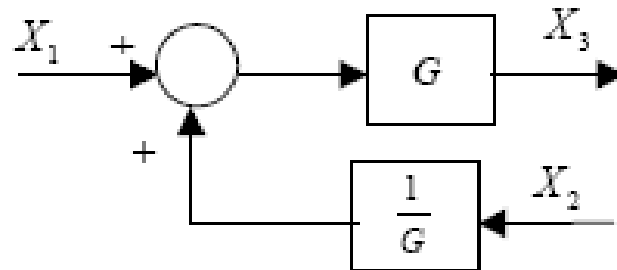
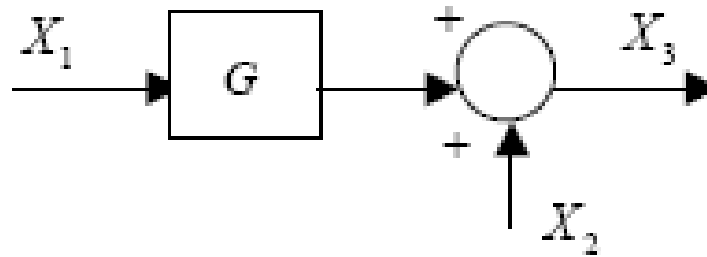

7. Eliminating a feedback loop

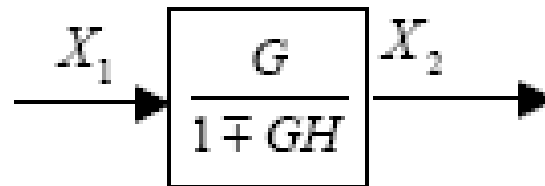
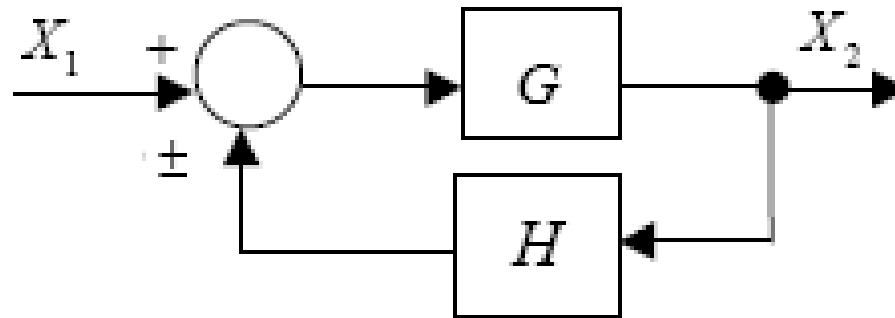

8. replacing summing points

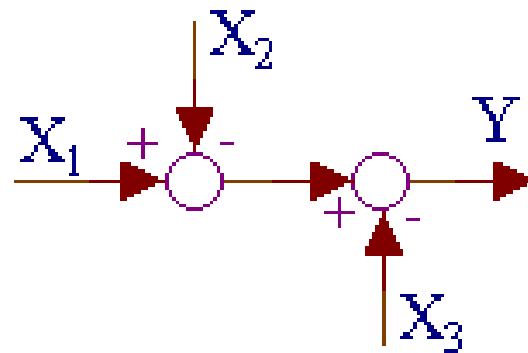
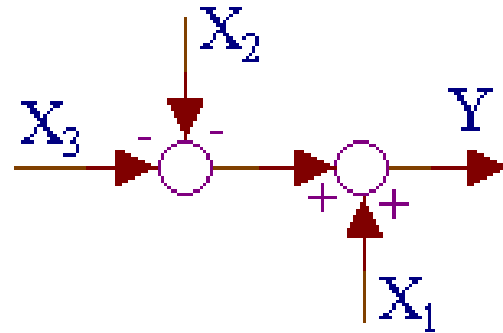

$$Y = X_1 - X_2 - X_3$$

9. Combining summing points

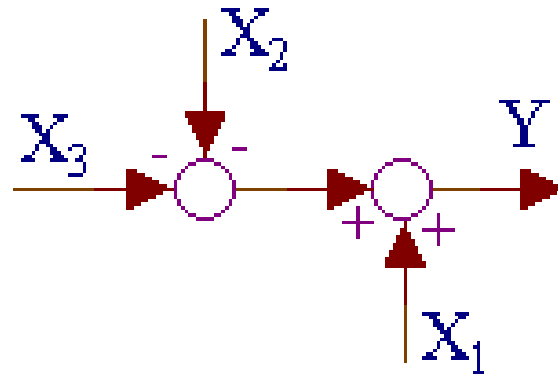

$$Y = X_1 - X_2 - X_3$$

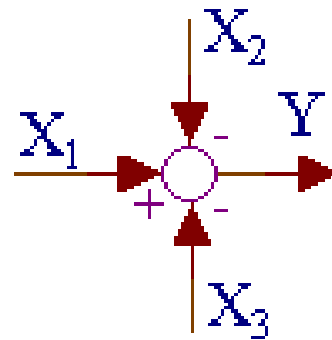

Attention

Don't use this

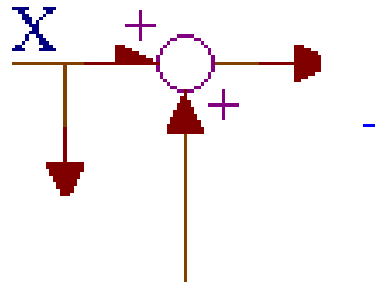

block diagram: reduction example

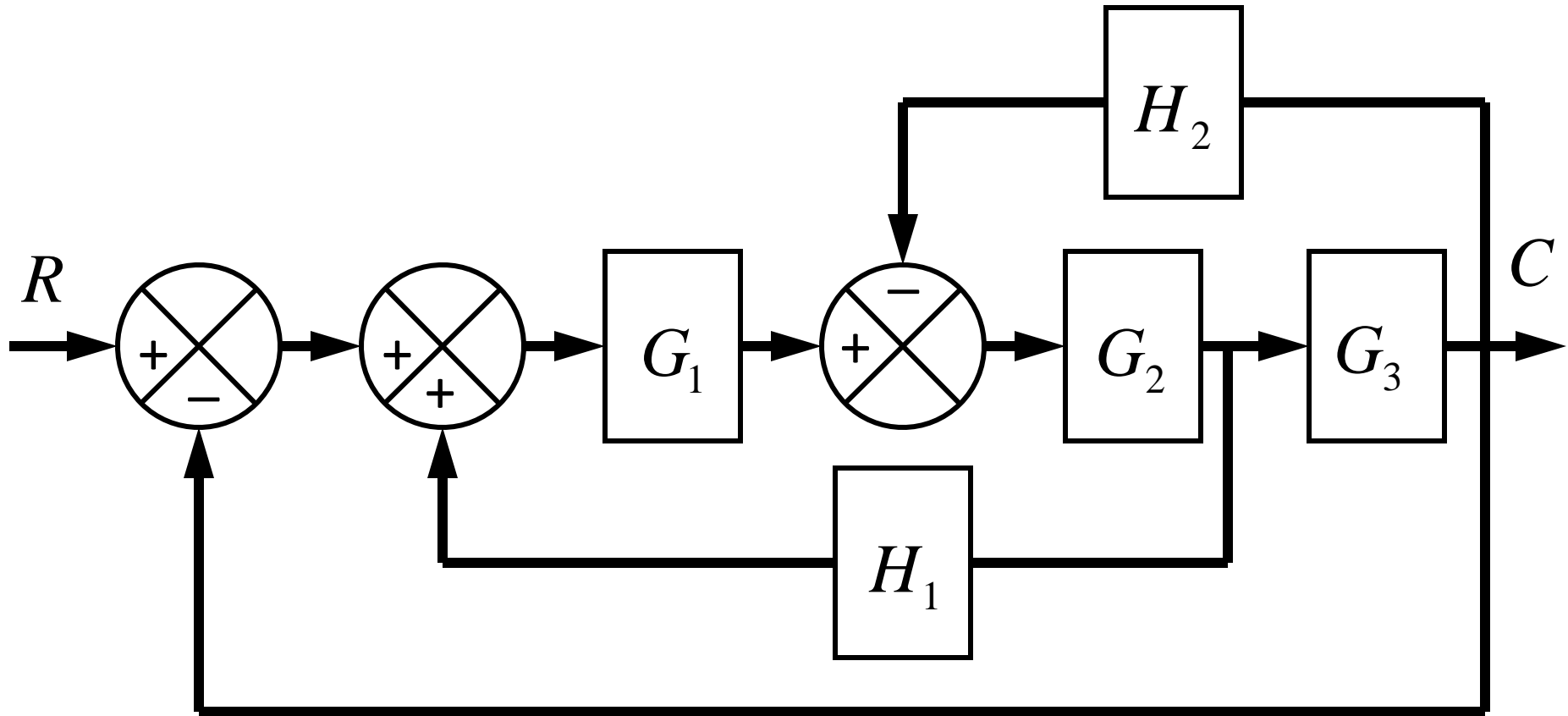

block diagram: reduction example

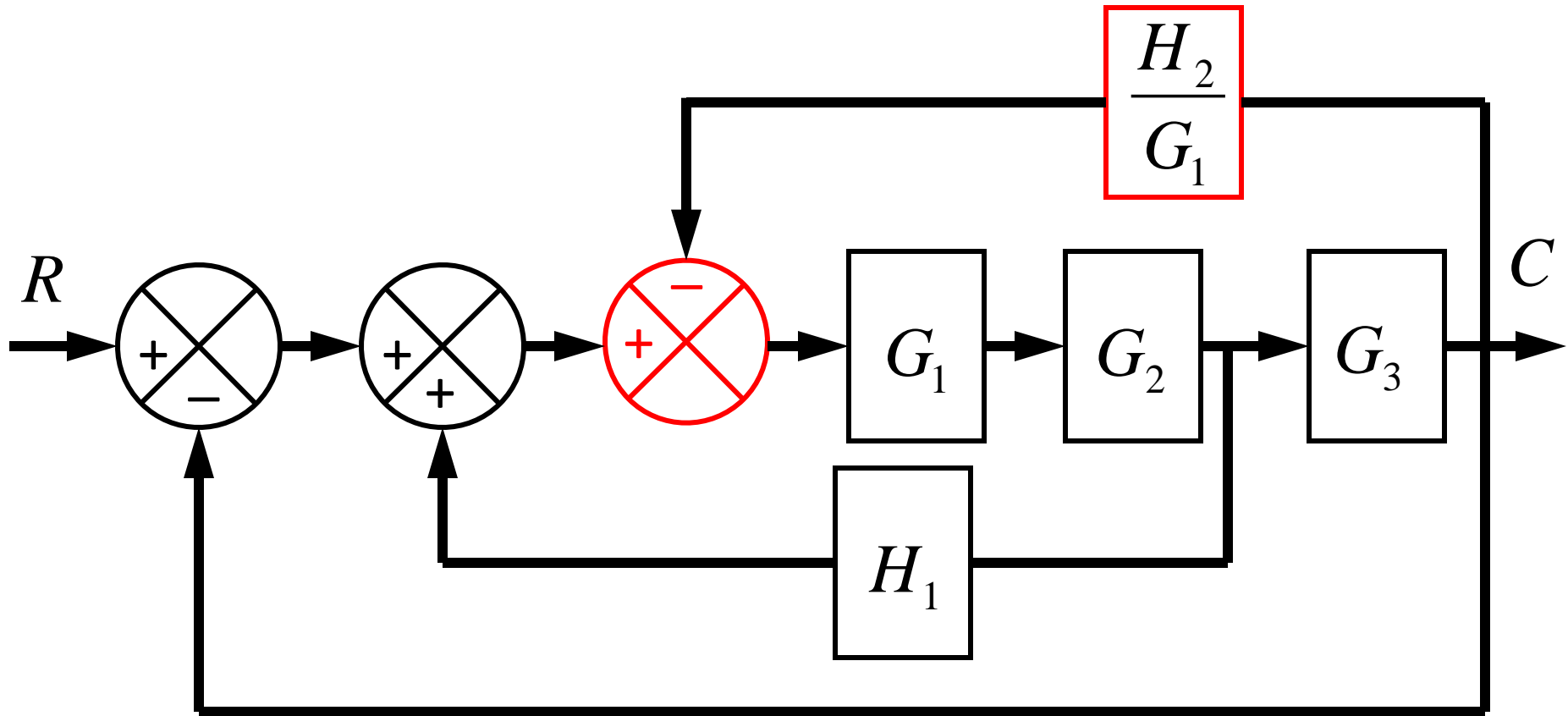

block diagram: reduction example

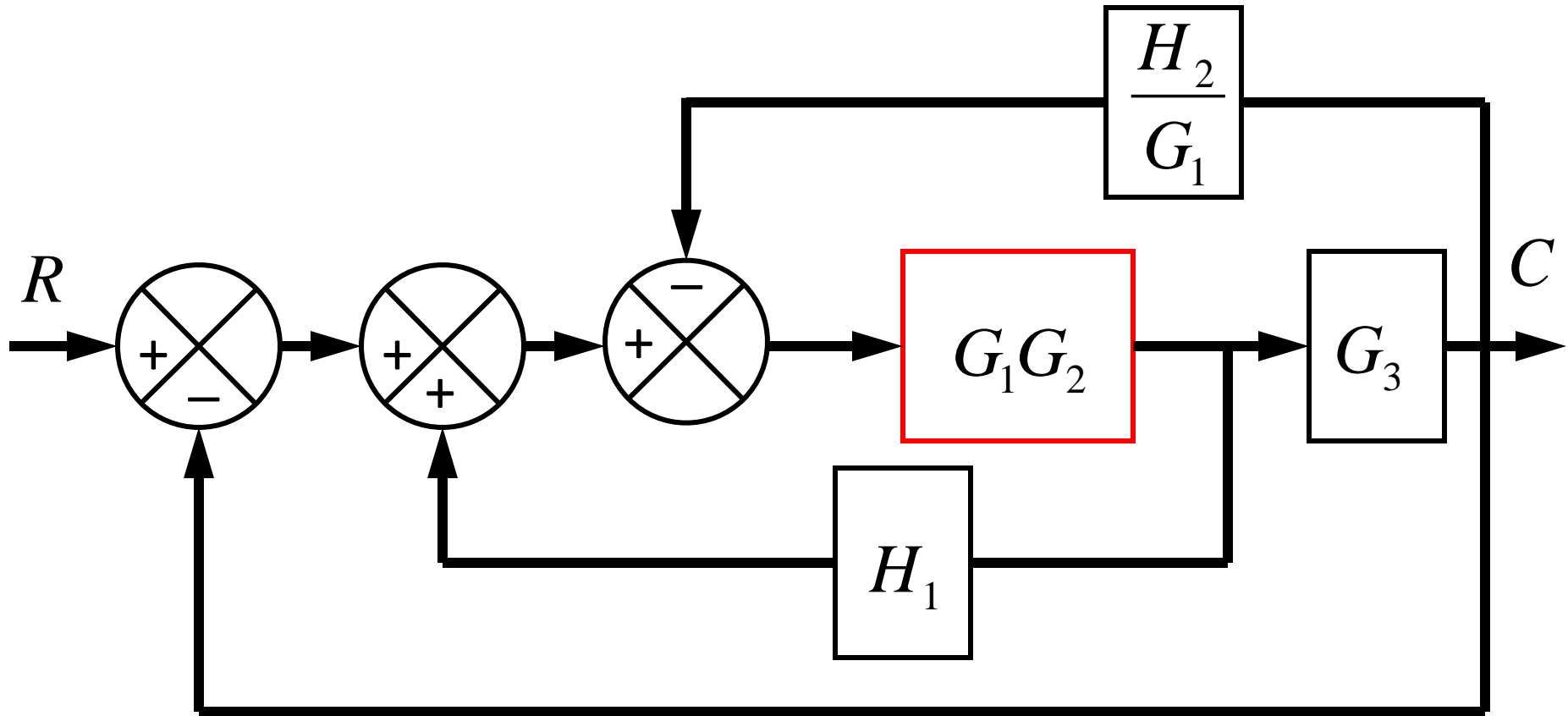

block diagram: reduction example

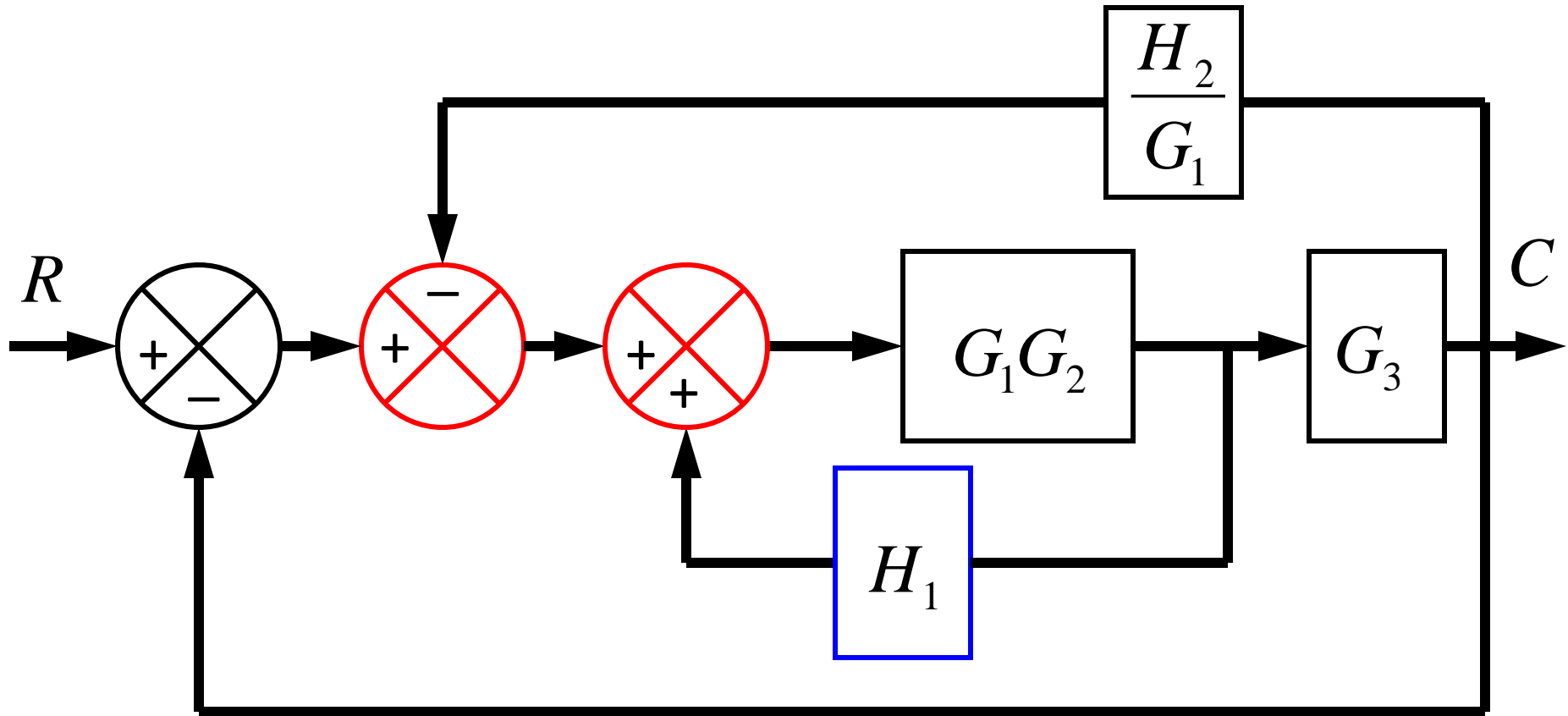

block diagram: reduction example

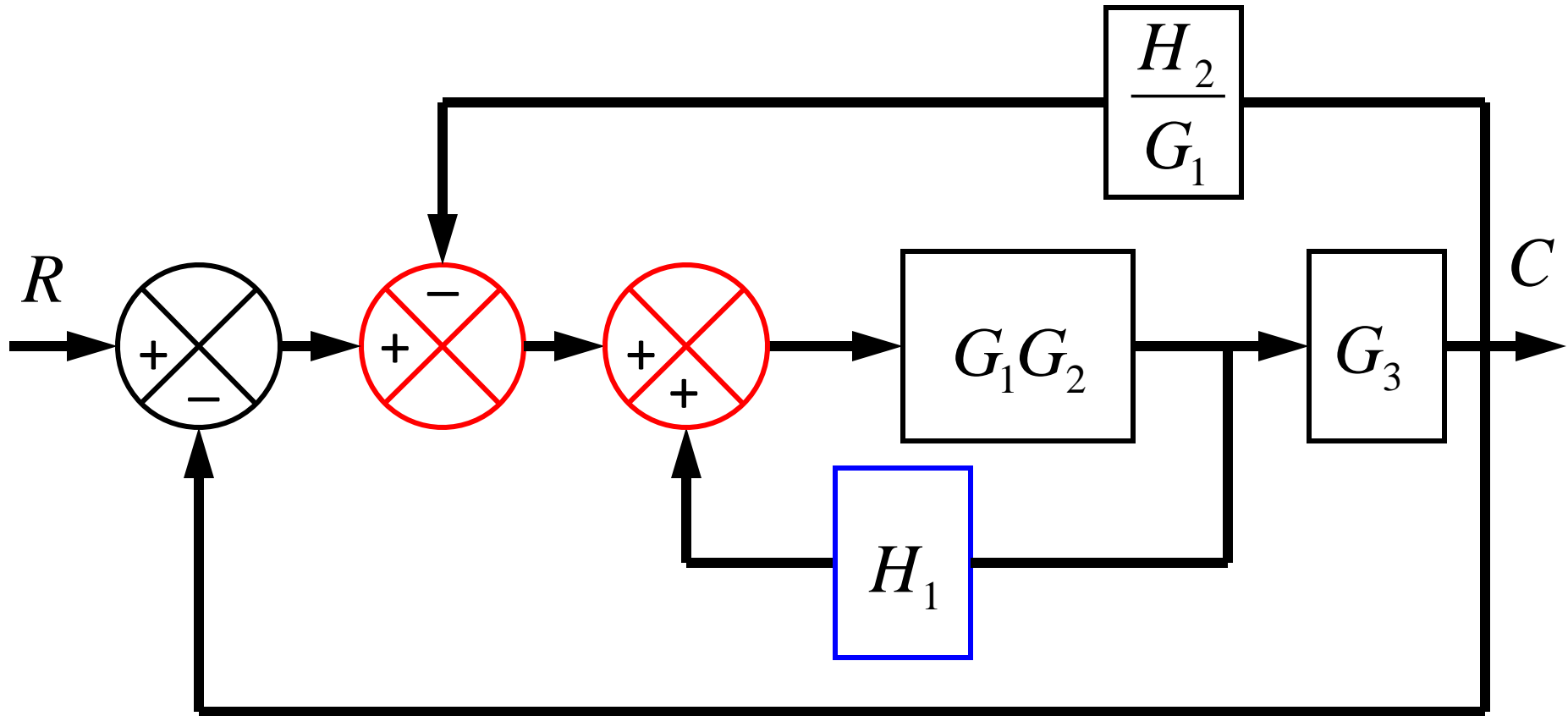

block diagram: reduction example

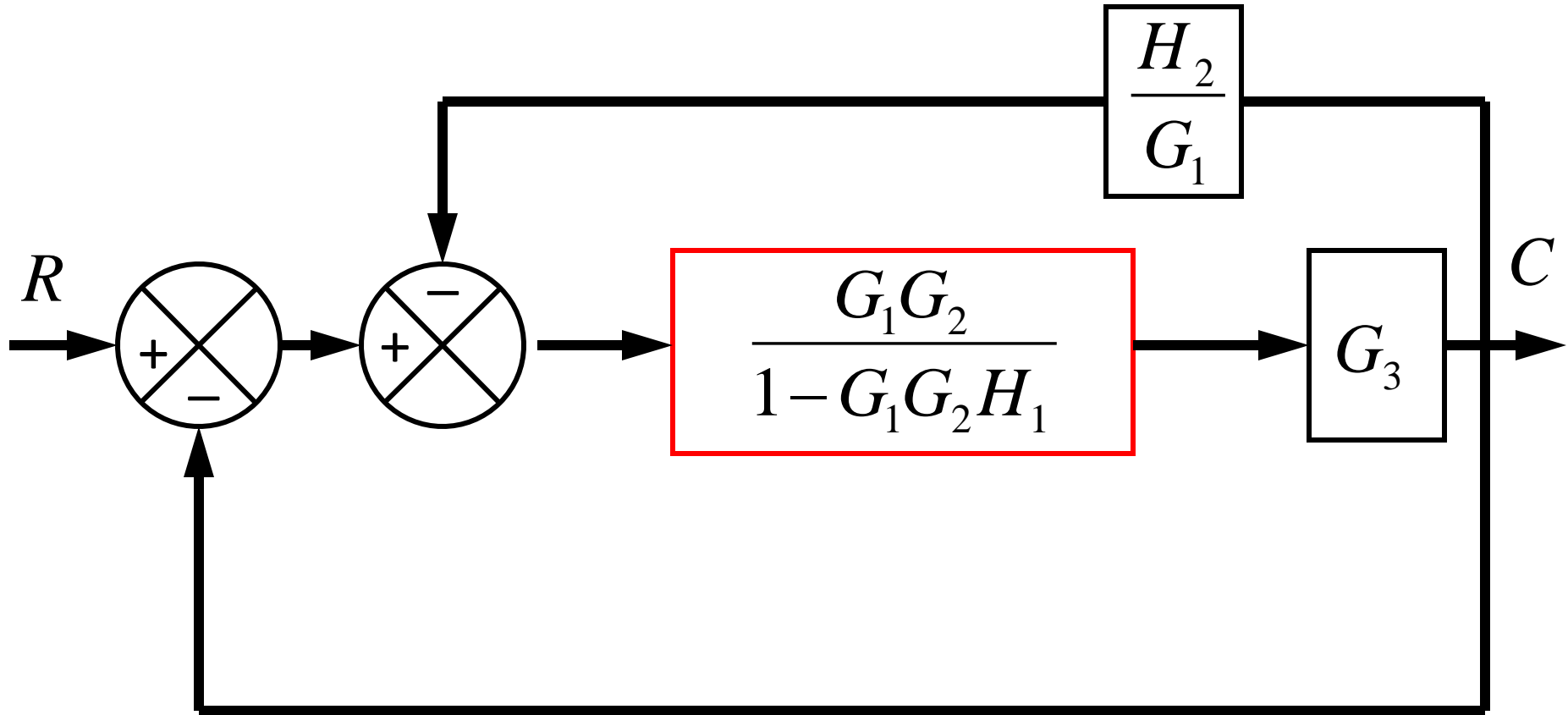

block diagram: reduction example

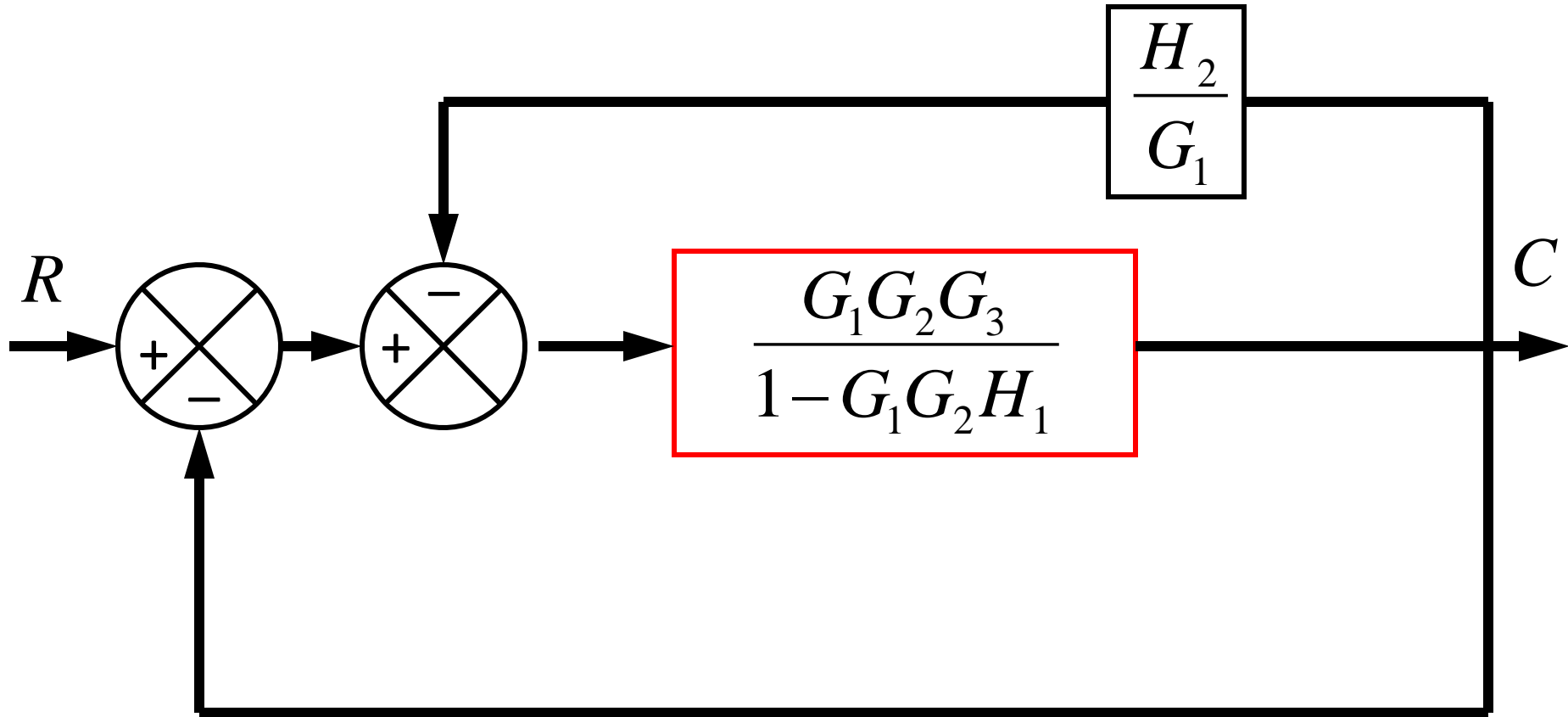

block diagram: reduction example

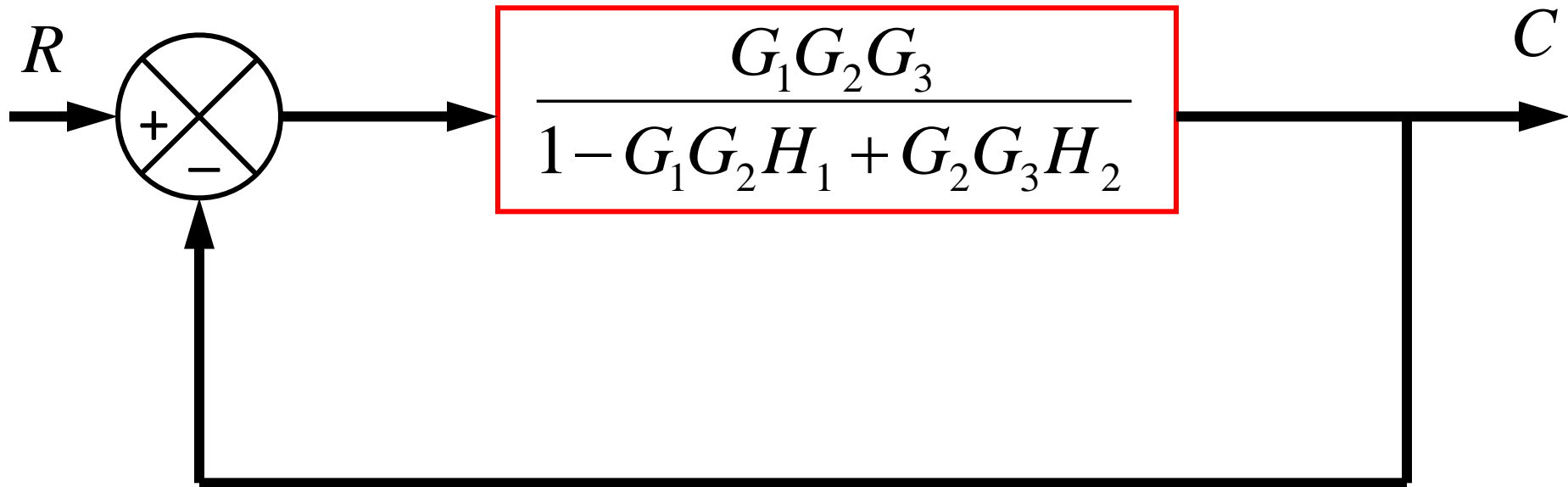

block diagram: reduction example

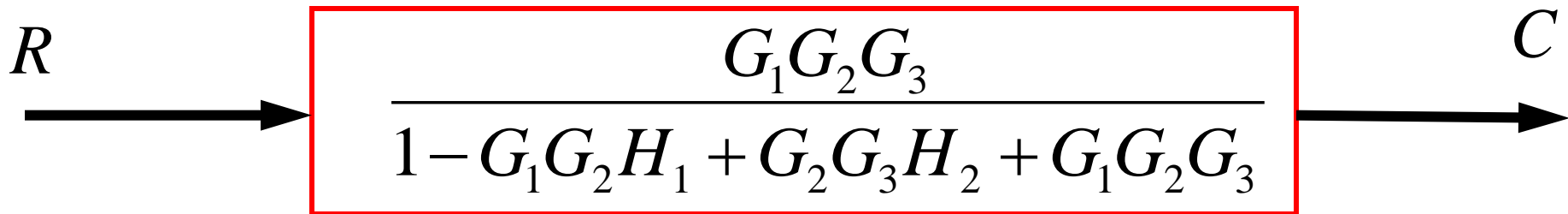

Example

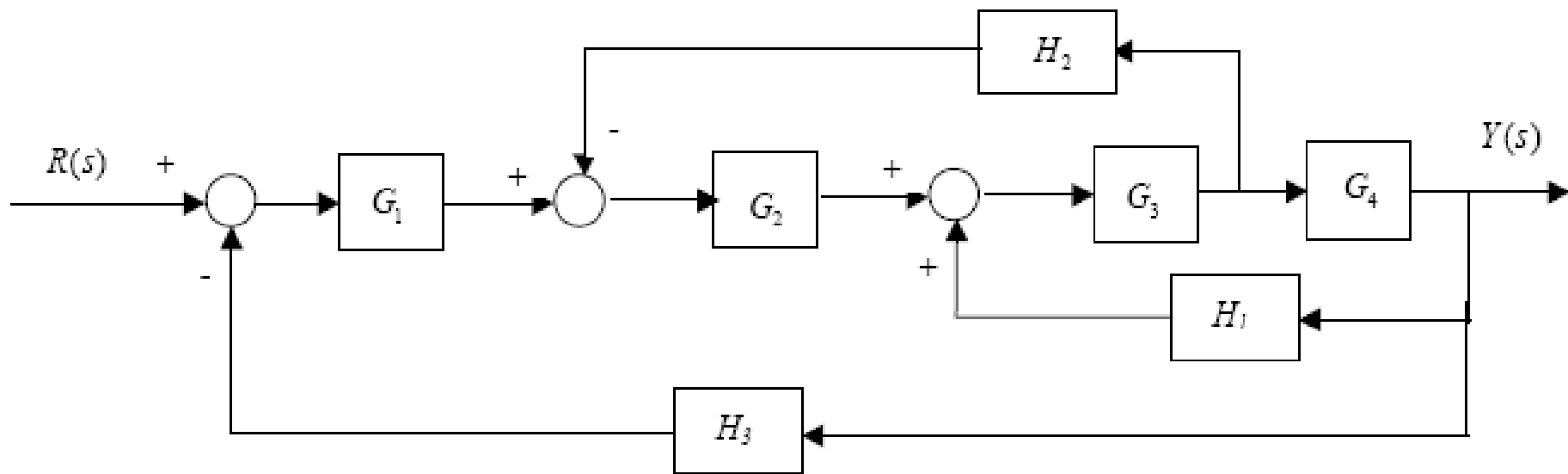

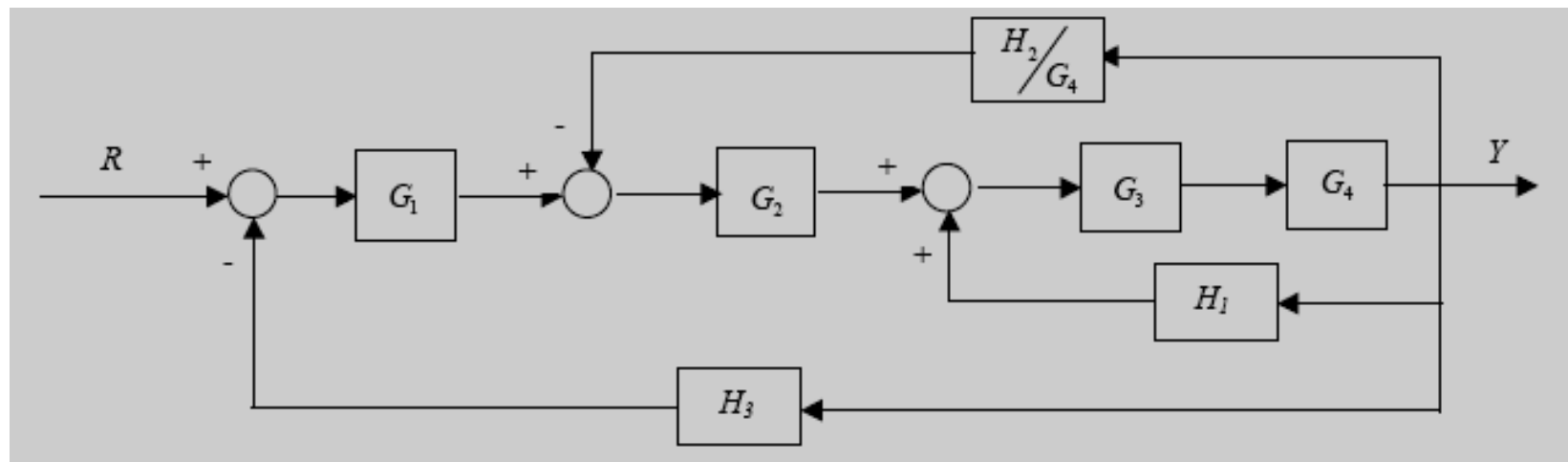

$$\begin{array}{c}
 R \longrightarrow \boxed{\frac{G_1 G_2 G_3 G_4}{1 - G_3 G_4 H_1 + G_2 G_3 H_2 + G_1 G_2 G_3 G_4 H_3}} \longrightarrow Y
 \end{array}$$

Example

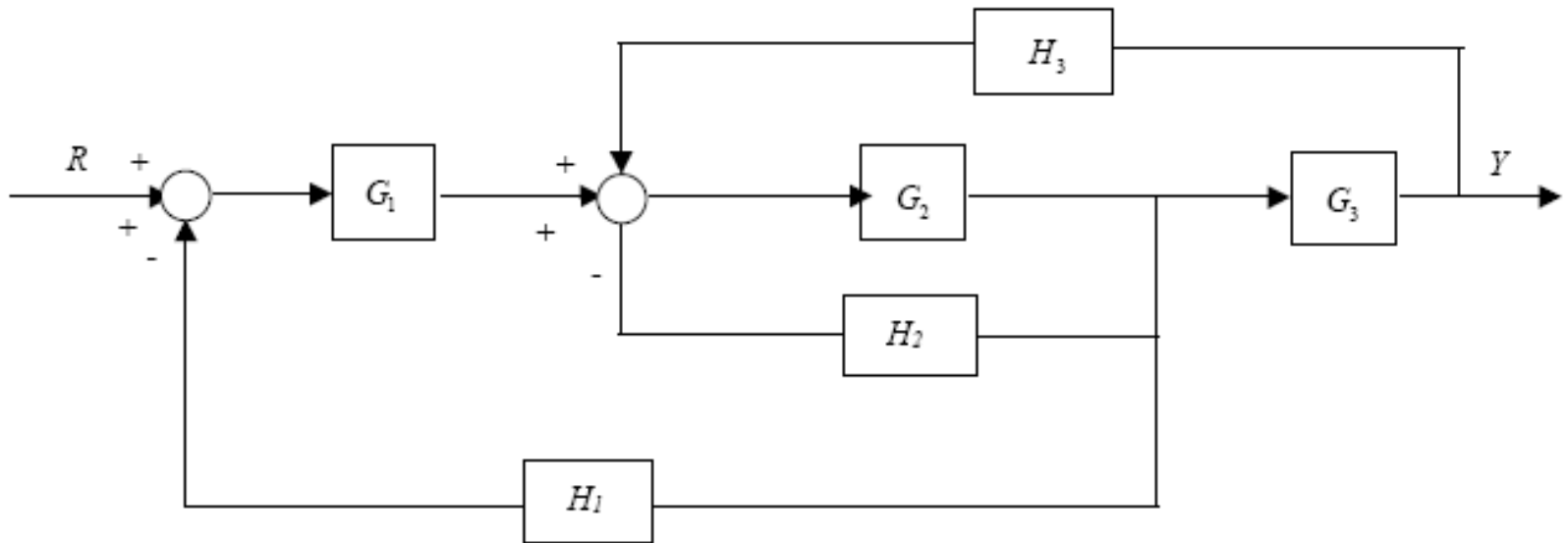

Example

