

# Deflection of Structural Members

- Slope and Elastic Curve
- Deflection Limits
- Diagrams by Parts
- Symmetrical Loading
- Asymmetrical Loading
- Deflection Equations and Superposition



CC:BY Tom Drew <http://creativecommons.org/licenses/by/3.0/>



# Slope

- The curved shape of a deflected beam is called the elastic curve
- The angle of a tangent to the elastic curve is called the slope, and is measured in radians.

$$\text{degrees} = \text{radians} \frac{180}{\pi}$$

- Slope is influenced by the stiffness of the member: material stiffness  $E$ , the modulus of elasticity; and sectional stiffness  $I$ , the moment of inertia, as well as the length of the beam.

$$\text{stiffness} = \frac{EI}{L}$$

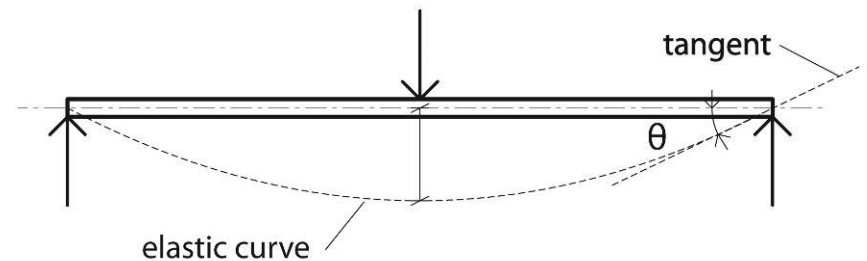

# Deflection

- Deflection is the distance that a beam bends from its original horizontal position, when subjected to loads.
- The compressive and tensile forces above and below the neutral axis, result in a shortening (above n.a.) and lengthening (below n.a.) of the longitudinal fibers of a simple beam, resulting in a curvature which deflects from the original position.

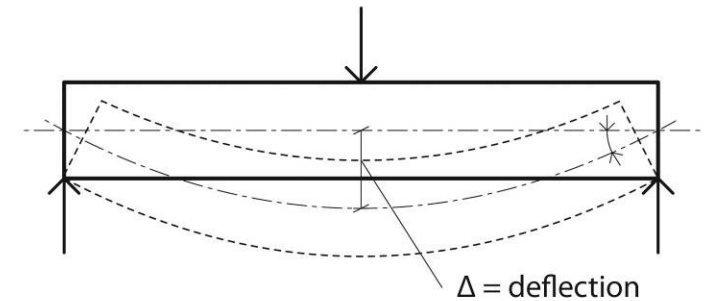

$$\text{stiffness} = \frac{EI}{L}$$

# Deflection Limits

- Various guidelines have been created, based on use classification, to determine maximum allowable deflection values
- Typically, a floor system with a LL deflection in excess of  $L/360$  will feel bouncy.
- Flat roofs with total deflections greater than  $L/120$  are in danger of ponding.

*Recommended allowable deflection limits.*

Use Classification	LL only	DL+LL
Roof Beams:		
Industrial	1/180	1/120
Commercial and Institutional		
without plaster ceiling	1/240	1/180
with plaster ceiling	1/360	1/240
Floor Beams:		
Ordinary Usage*	1/360	1/240

*\*Ordinary usage is for floors intended for construction in which walking comfort and the minimizing of plaster cracking are primary considerations.*

Source: Standard Building Code - 1991

**L = span**

# Relationships of Forces and Deformations

There are a series of relationships among forces and deformations along a beam, which can be useful in analysis. Using either the deflection or load as a starting point, the following characteristics can be discovered by taking successive derivatives or integrals of the beam equations.

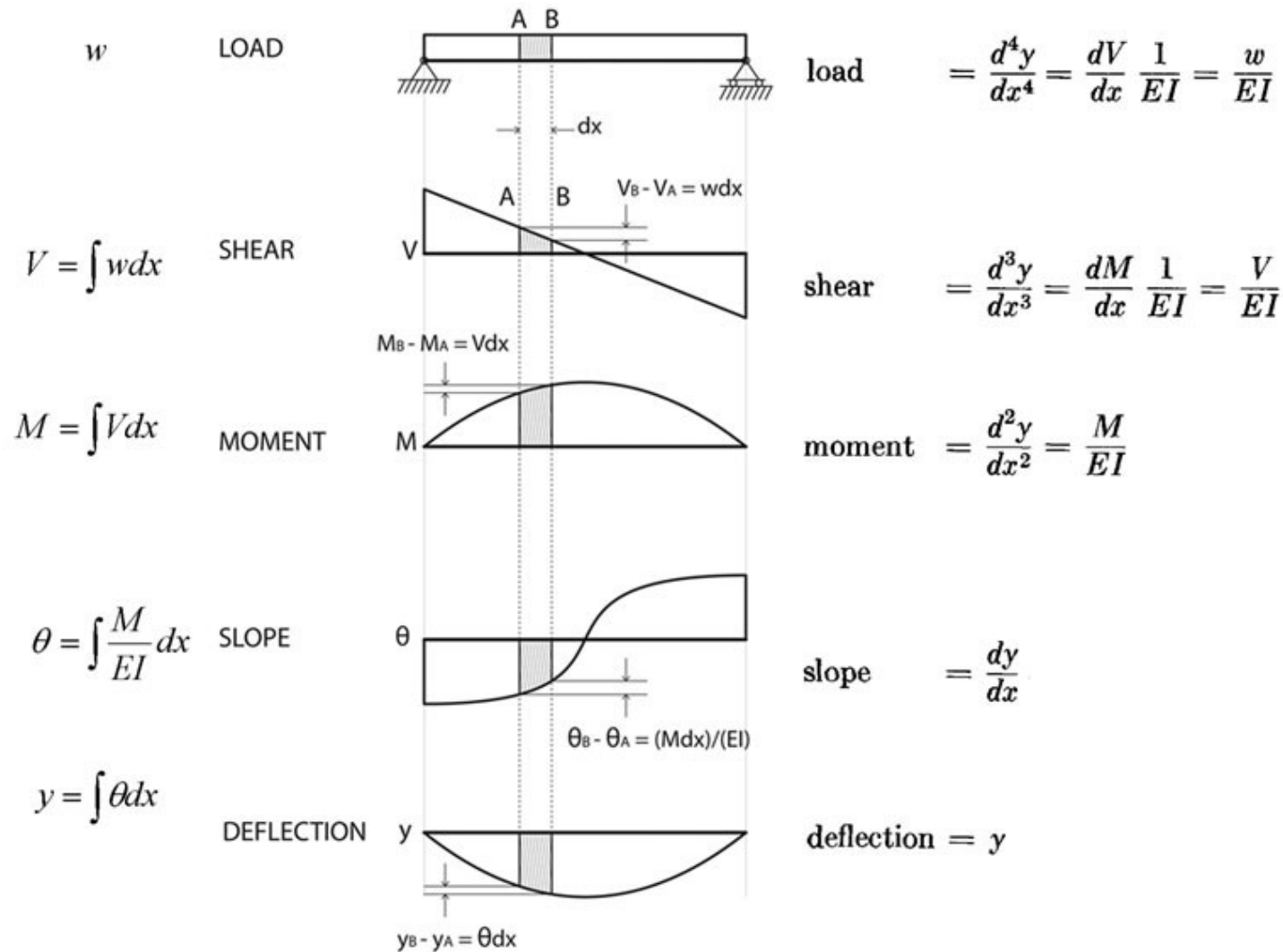

# Symmetrically Loaded Beams

- Maximum slope occurs at the ends of the beam
- A point of zero slope occurs at the center line. This is the point of maximum deflection.
- Moment is positive for gravity loads.
- Shear and slope have balanced + and - areas.
- Deflection is negative for gravity loads.

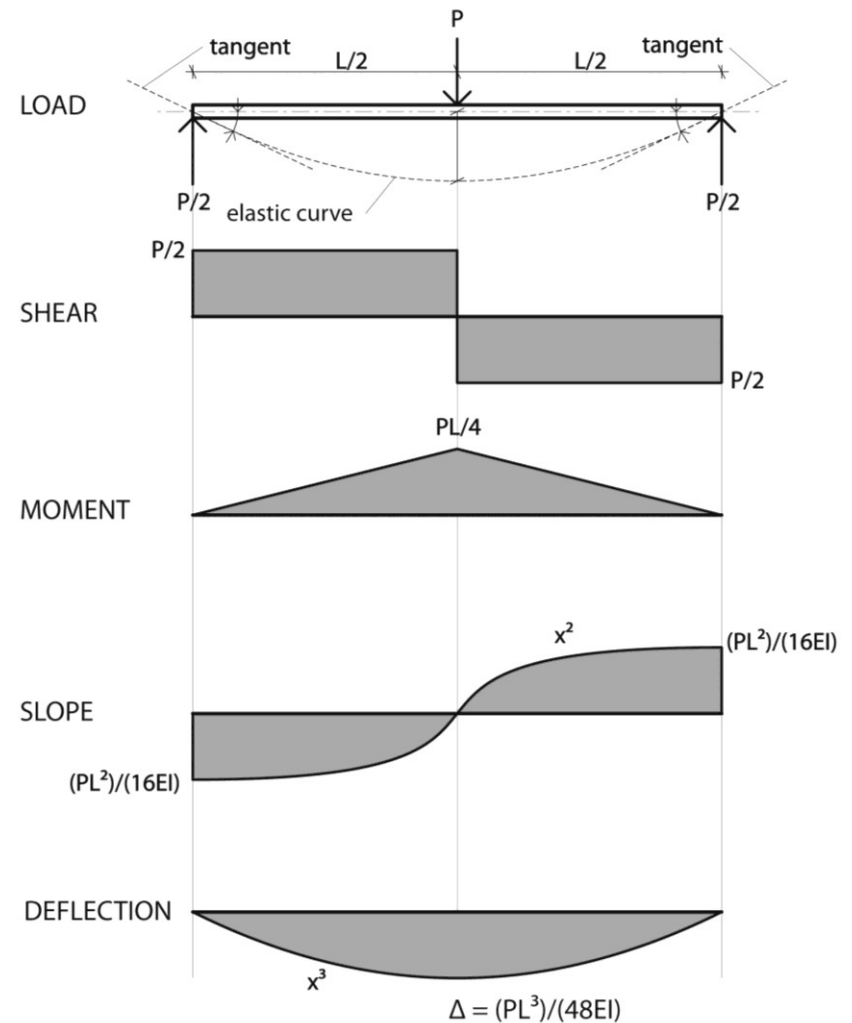

# Cantilever Beams

- One end fixed. One end free
- Fixed end has maximum moment, but zero slope and deflection.
- Free end has maximum slope and deflection, but zero moment.
- Slope is either downward (-) or upward (+) depending on which end is fixed.
- Shear sign also depends of which end is fixed.
- Moment is always negative for gravity loads.

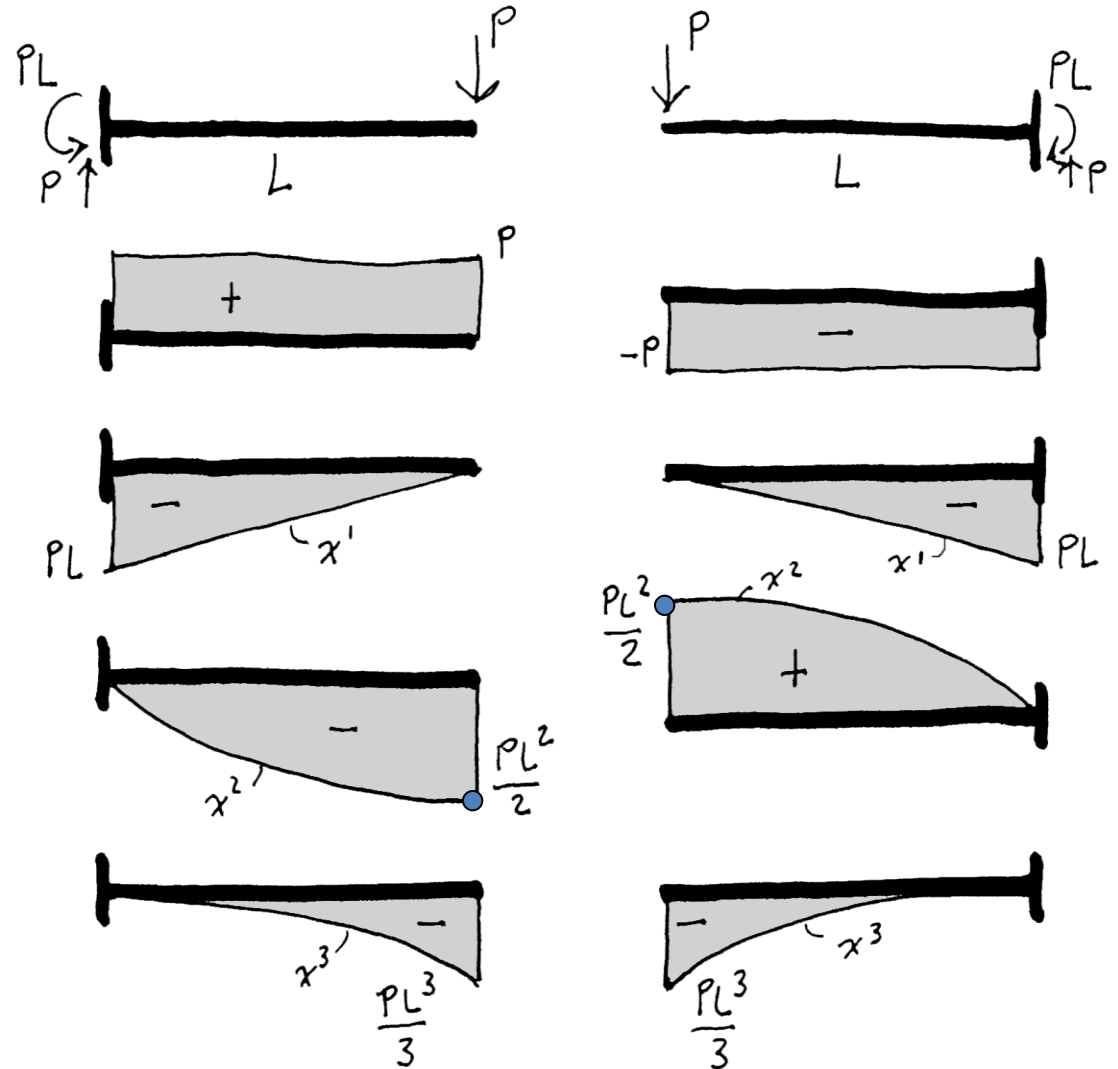



# Diagrams by Parts

● marks vertex which must be present for area equations to be valid.

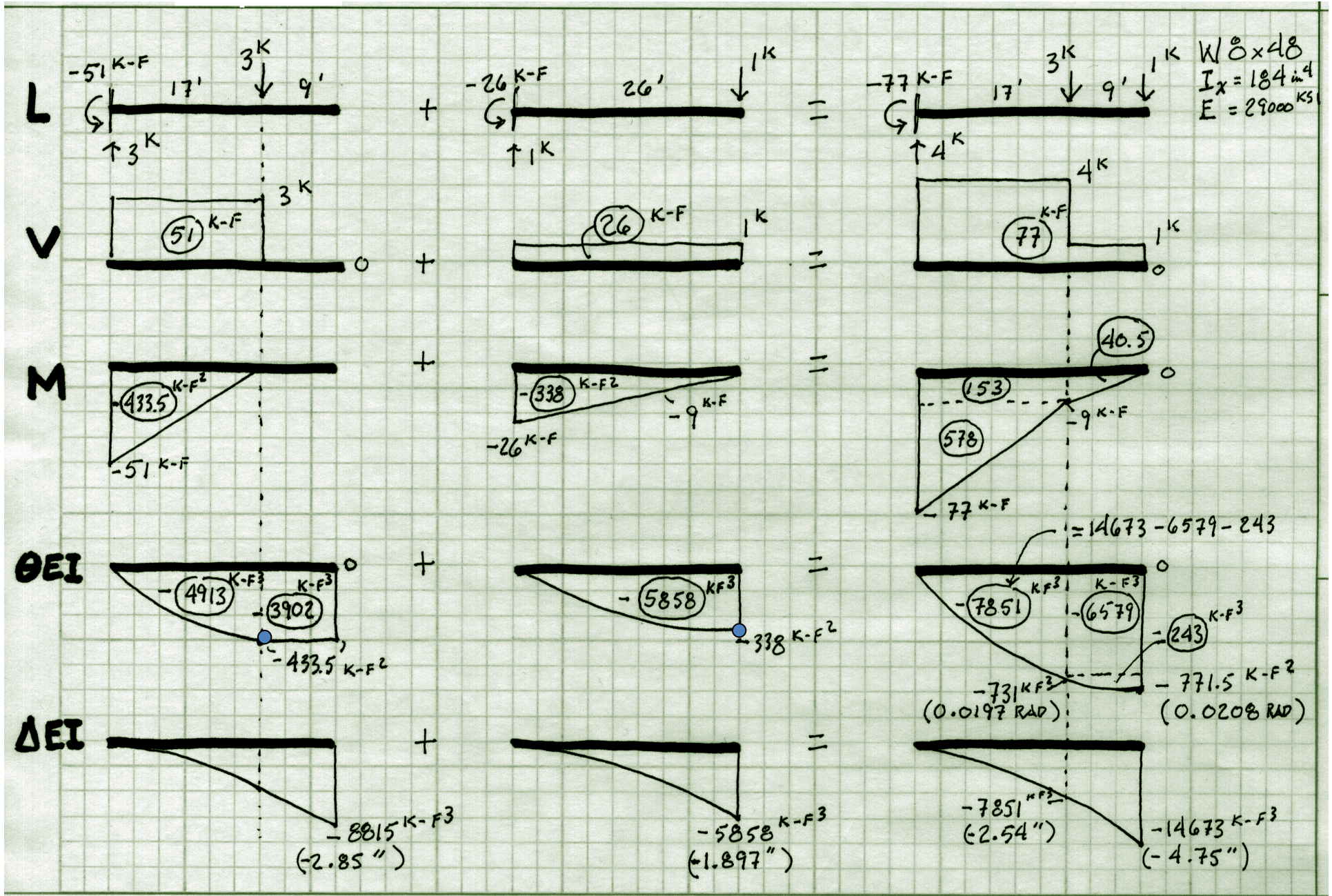



# Asymmetrically Loaded Beams

## Diagram Method

- The value of the slope at each of the endpoints is different.
- The exact location of zero slope (and maximum deflection) is unknown.
- Start out by assuming a location of zero slope (Choose a location with a known dimension from the loading diagram)
- With the arbitrary location of zero slope, the areas above and below the baseline (“A” and “B”) are unequal
- Adjust the baseline up or down by  $D$  distance in order to equate areas “A” and “B”. Shifting the baseline will remove an area “a” from “A” and add an area “b” to “B”

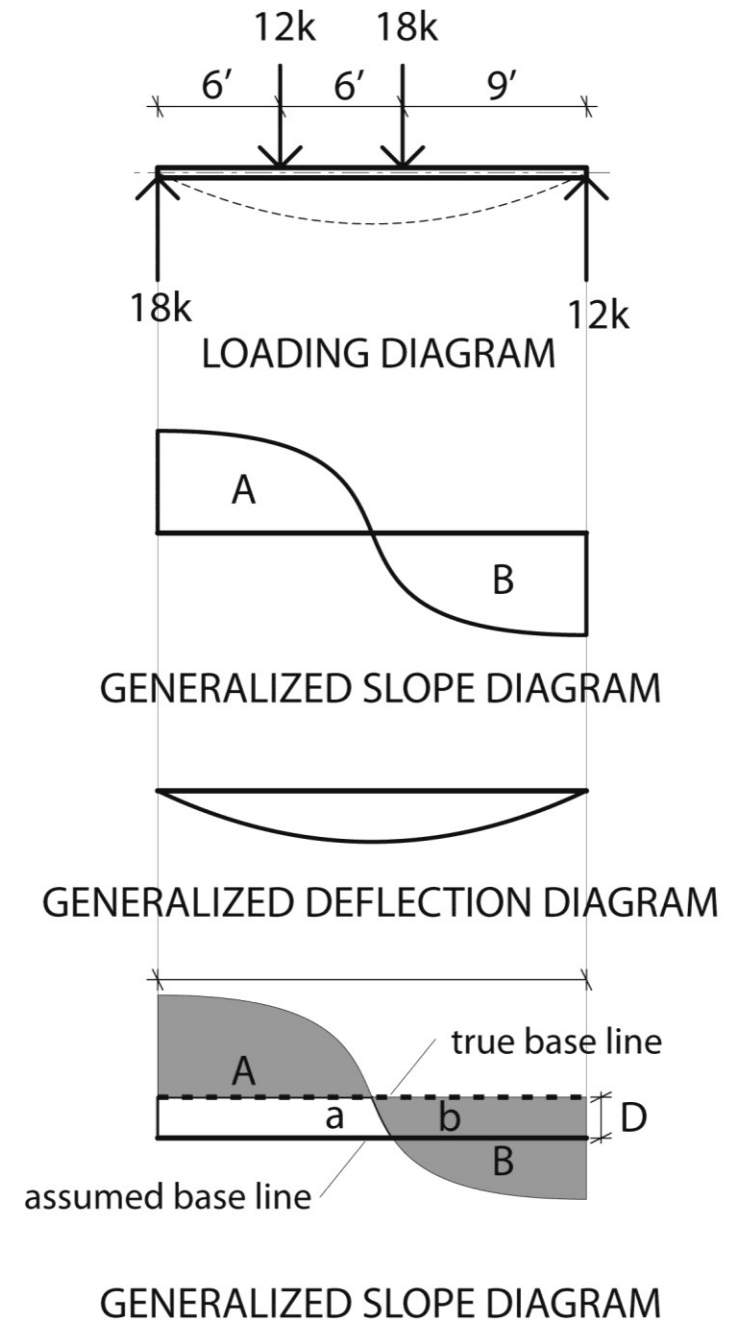

# Asymmetrically Loaded Beams

(continued)

- Compute distance  $D$  with the equation:

$$D = \frac{|A - B|}{L}$$

- With the vertical shift of the baseline, a horizontal shift occurs in the position of zero slope.
- The new position of zero slope will be the actual location of maximum deflection.
- Compute the area under the slope diagram between the endpoint and the new position of zero slope in order to compute the magnitude of the deflection.

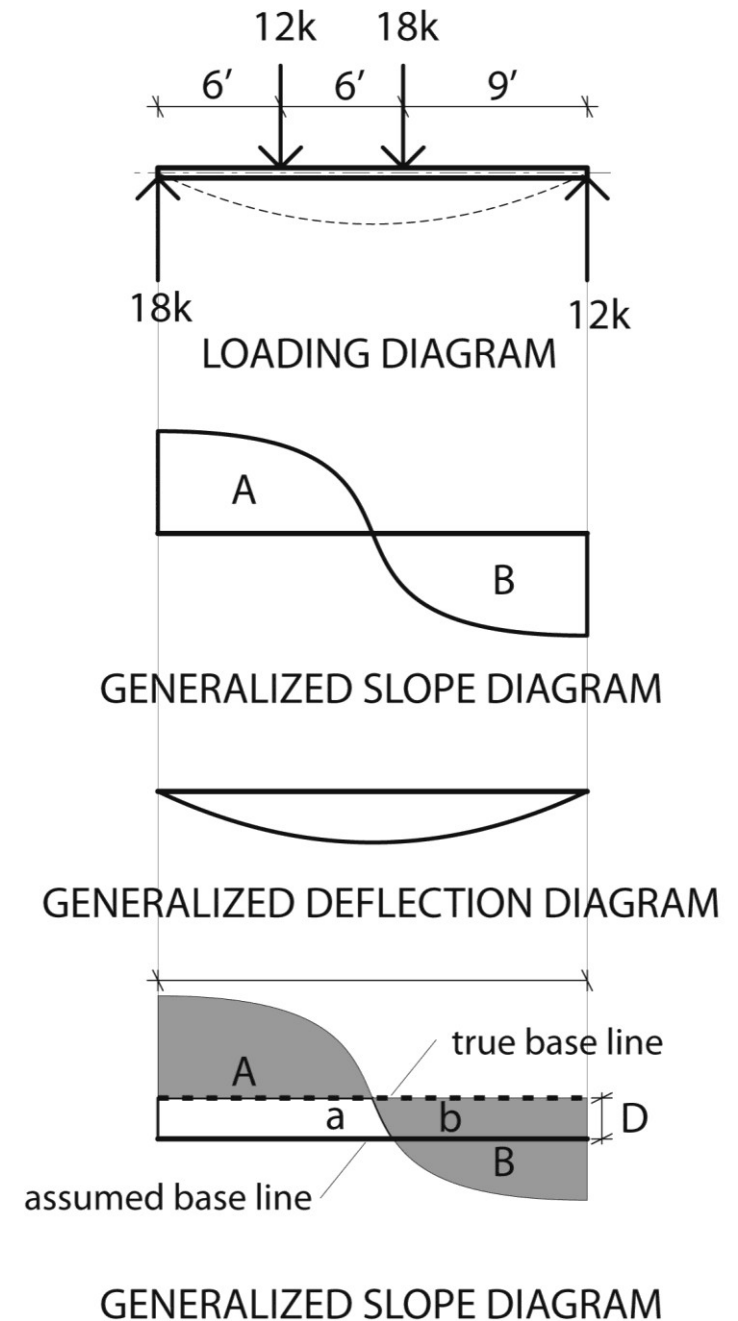

# Example: Asymmetrical Loading – Diagram method

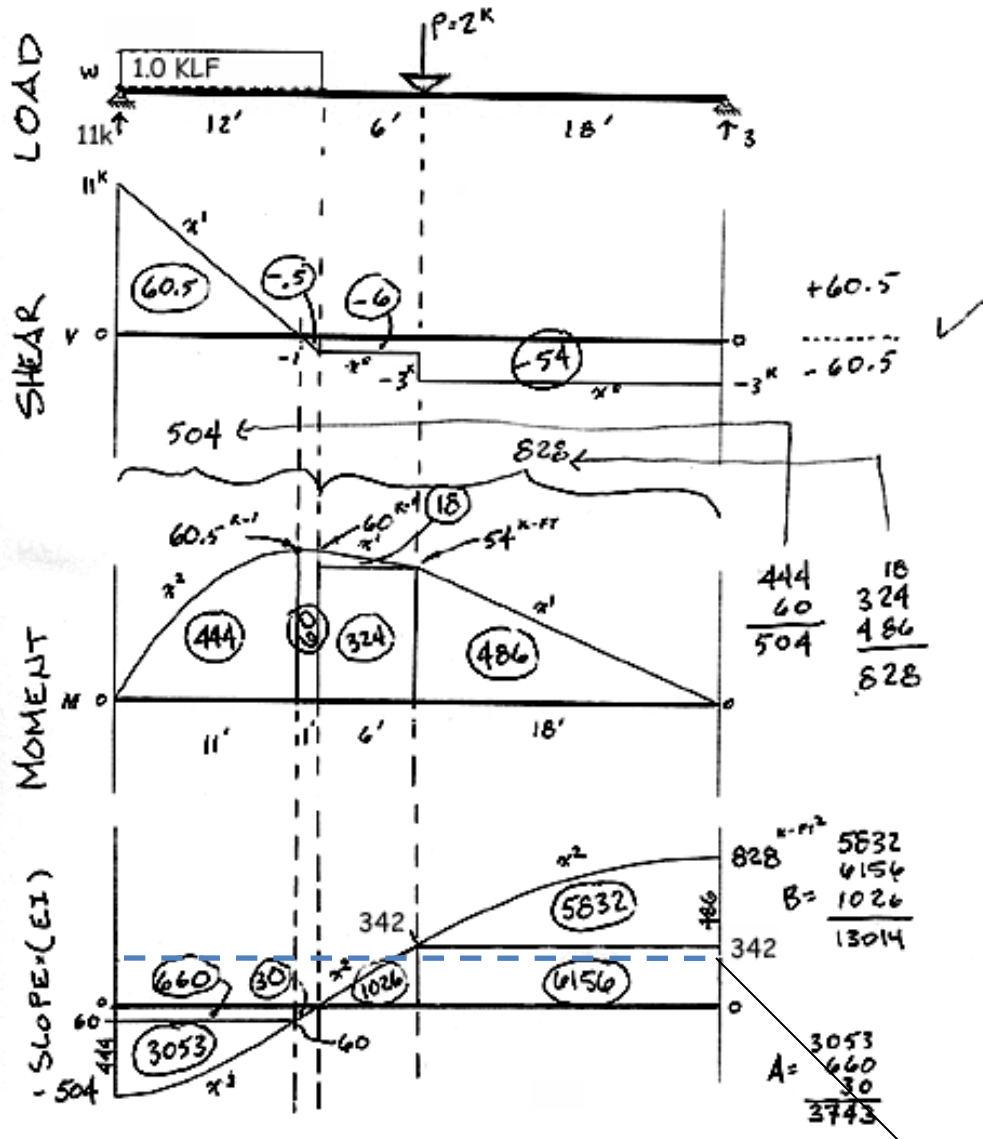

ADJUSTED BASE LINE

$$D = \frac{|A - B|}{L} = \frac{|3743 - 13014|}{36'} = 258$$

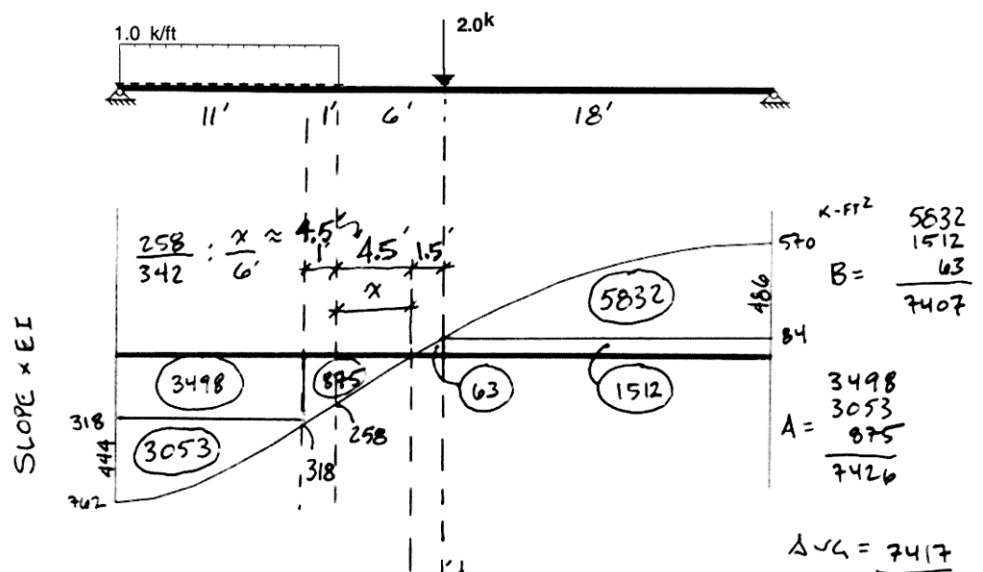

$$\Delta = \frac{7417 (1728)}{EI} \text{ INCHES}$$

FOR W12x26    E = 29000 KSI    I = 204 in<sup>4</sup>

$$\Delta = 2.17''$$

# Deflection: by Superposition of Equations

- Deflection can be determined by the use of equations for specific loading conditions
- See Data Sheet D-25 for more examples
- By “superposition” equations can be added for combination load cases. Care should be taken that added equations all give deflection at the same point, e.g. the center line.
- Note that if length and load (w) is entered in feet, a conversion factor of 1728 in<sup>3</sup>/ft<sup>3</sup> must be applied in order to compute deflection in inches.

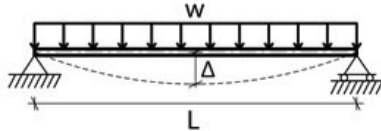
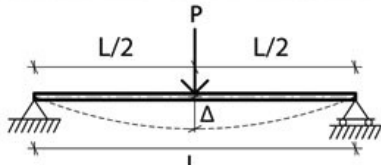
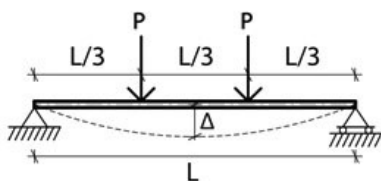
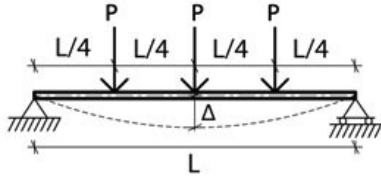
Beam Load and Support	Actual Deflection*
 <p>(a) Uniform load, simple span</p>	$\Delta_{\max} = \frac{5wL^4}{384EI}$ <p>(at the centerline)</p>
 <p>(b) Concentrated load at midspan</p>	$\Delta_{\max} = \frac{PL^3}{48EI}$ <p>(at the centerline)</p>
 <p>(c) Two equal concentrated loads at third points</p>	$\Delta_{\max} = \frac{23PL^3}{648EI} = \frac{PL^3}{28.2EI}$ <p>(at the centerline)</p>
 <p>(d) Three equal concentrated loads at quarter points</p>	$\Delta_{\max} = \frac{PL^3}{20.1EI}$ <p>(at the centerline)</p>



## Example: Equations Method

- To determine the total deflection of the beam for the given loading condition, begin by breaking up the loading diagram into two parts.
- Compute the total deflection by superimposing the deflections from each of the individual loading conditions. In this example, use the equation for a midspan point load and the equation for a uniform distributed load.

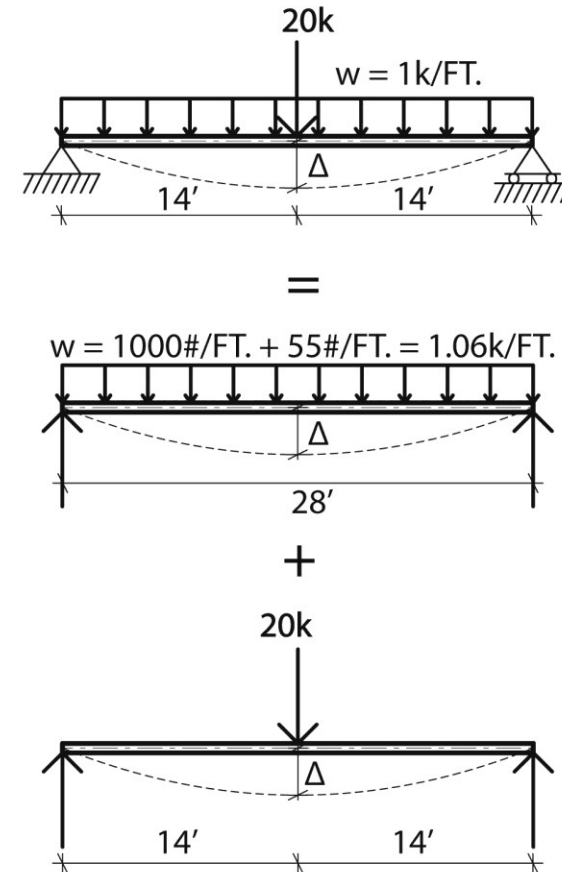

$$\Delta_{\text{actual}} = \frac{PL^3}{48EI} + \frac{5\omega L^4}{384EI}$$

# Example: Equations Method

- For a W18x55 with an E modulus of 30000 ksi and a moment of inertia of 890 in<sup>4</sup>
- Using an allowable deflection limit of L / 240.
- Check deflection

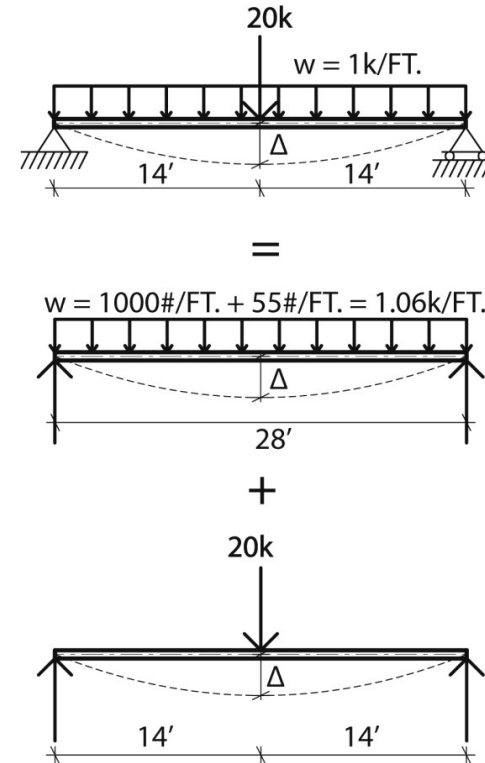

$$\Delta_{\text{allow}} = \frac{L}{240} = \frac{28' \times 12 \text{ in./ft.}}{240} = 1.4''$$

$$\Delta_{\text{actual}} = \frac{PL^3}{48EI} + \frac{5\omega L^4}{384EI}$$

$$\Delta_{\text{actual}} = \frac{20 \text{ k}(28')^3 1,728}{48(30 \times 10^3)(890)} + \frac{5(1.06 \text{ k/ft.})(28')^4 1,728}{(384)(30 \times 10^3)(890)}$$

$$\Delta_{\text{actual}} = 0.59'' + 0.55'' = 1.41'' < 1.4'' \therefore \text{OK}$$

# Example: Asymmetrical Loading – Superposition of Equations

Standard equations provide values of shear, moment and deflection at points along a beam.

Cases can be “superpositioned” or overlaid to obtain combined values.

To find the point of combined maximum deflection, the derivative of the combined deflection equation can be solved for 0. This gives the point with slope = 0 which is a max/min on the deflection curve.

## 5. SIMPLE BEAM—UNIFORM LOAD PARTIALLY DISTRIBUTED AT ONE END

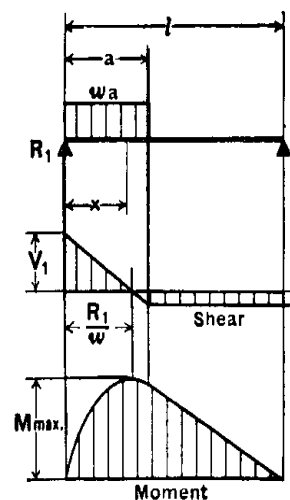

$$\begin{aligned}
 R_1 &= V_1 \text{ max.} \dots\dots\dots = \frac{wa}{2l} (2l-a) \\
 R_2 &= V_2 \dots\dots\dots = \frac{wa^2}{2l} \\
 V_x &\left( \text{when } x < a \right) \dots\dots\dots = R_1 - wx \\
 M \text{ max.} &\left( \text{at } x = \frac{R_1}{w} \right) \dots\dots\dots = \frac{R_1^2}{2w} \\
 M_x &\left( \text{when } x < a \right) \dots\dots\dots = R_1x - \frac{wx^2}{2} \\
 M_x &\left( \text{when } x > a \right) \dots\dots\dots = R_2(l-x) \\
 \Delta_x &\left( \text{when } x < a \right) \dots\dots\dots = \frac{wx}{24EI} \left( a^2(2l-a)^2 - 2ax^2(2l-a) + lx^3 \right) \\
 \Delta_x &\left( \text{when } x > a \right) \dots\dots\dots = \frac{wa^2(l-x)}{24EI} (4xl - 2x^2 - a^2)
 \end{aligned}$$

## 8. SIMPLE BEAM—CONCENTRATED LOAD AT ANY POINT

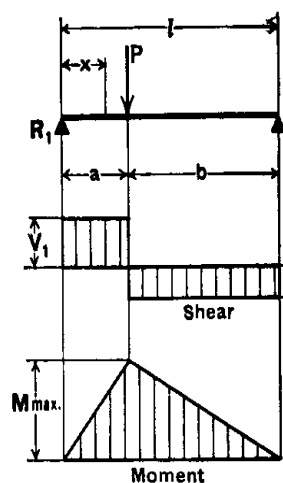

$$\begin{aligned}
 \text{Total Equiv. Uniform Load} \dots\dots\dots &= \frac{8 Pab}{l^2} \\
 R_1 &= V_1 \left( \text{max. when } a < b \right) \dots\dots\dots = \frac{Pb}{l} \\
 R_2 &= V_2 \left( \text{max. when } a > b \right) \dots\dots\dots = \frac{Pa}{l} \\
 M \text{ max.} &\left( \text{at point of load} \right) \dots\dots\dots = \frac{Pab}{l} \\
 M_x &\left( \text{when } x < a \right) \dots\dots\dots = \frac{Pbx}{l} \\
 \Delta_{\text{max.}} &\left( \text{at } x = \sqrt{\frac{a(a+2b)}{3}} \text{ when } a > b \right) = \frac{Pab(a+2b)\sqrt{3a(a+2b)}}{27EI} \\
 \Delta_a &\left( \text{at point of load} \right) \dots\dots\dots = \frac{Pa^2b^2}{3EI} \\
 \Delta_x &\left( \text{when } x < a \right) \dots\dots\dots = \frac{Pbx}{6EI} (l^2 - b^2 - x^2)
 \end{aligned}$$

## Example (same as above): Asymmetrical Loading - Superposition

USING SUPERPOSITION OF CASE 5 + CASE 8

$$\Delta @ x = \text{CASE 5} + \text{CASE 8}$$

$$\Delta = \frac{w a^2 (l-x)(4xl - 2x^2 - a^2)}{24 E I l} + \frac{P_b x (l^2 - b^2 - x^2)}{6 E I l}$$

$$E I \Delta = \frac{1(12^2)(36-x)(4 \times 36 - 2x^2 - 12^2)}{24(36)} + \frac{2(18)x(36^2 - 18^2 - x^2)}{6(36)}$$

$$= \left(6 - \frac{x}{6}\right)(144x - 2x^2 - 144) + \frac{x}{6}(972 - x^2)$$

$$= \frac{x^3}{6} - 36x^2 + 1050x - 864$$

$$f'(x) = \frac{x^2}{2} - 72x + 1050$$

THIS IS THE EQUATION  
FOR SLOPE FOR  $12 < x < 18$   
WHERE SLOPE = 0,  $\Delta = \text{MAX}$

$$0 = \frac{x^2}{2} - 72x + 1050$$

$$x = \frac{144 \pm 4\sqrt{771}}{2} \rightarrow$$

$$x = 127.5$$

$$x = 16.4662'$$