

Overview

- ▶ Introduction
 - ▶ Basic Concepts
 - ▶ Theory
 - ▶ Strain Tensor
 - ▶ Stress Tensor
 - ▶ Example
 - ▶ Conclusion
- 

Introduction

- ▶ Not all deformation is elongational or compressive. The concept of strain can be extended to inclined shearing or distortional effects.
- ▶ The deformation of a circular cylinder rod by surface tractions applied at the end forces can be studied using basic concepts of continuum mechanics.
- ▶ The formulas for deformation and stresses in circular cylinder of linear elastic material subjected to torsion are developed .The state of stress in pure shear and state of strain are analyzed.

Continuum Mechanics Approach

- ▶ Solid Mechanics is the study of load carrying members in terms of forces, deformations and stability.
- ▶ The Continuum Mechanics Approach is applied, because the material properties are taken to be the same even when we consider infinitesimal areas and volumes.
- ▶ Alternative Approach

There are many alternative approaches to study solid mechanics.

Such as from basic equations relating atomic forces and interactions are used to build up material properties and then extending it to large sets of such entities.

For example Molecular Dynamics

Torque

- ▶ Twisting moments or torques are forces acting through distance so as to promote rotation.

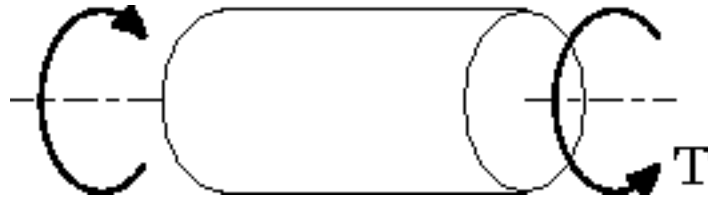

Example

Using a wrench to tighten a nut in a bolt.

If the bolt, wrench and force are all perpendicular to one another, the moment is the force F times the length of the wrench.

$$\text{Simple torque : } T = F * l$$

Torsion

- ▶ Torsion is the twisting of a straight bar when it is loaded by twisting moments or torques that tend to produce rotation about the longitudinal axes of the bar.

For instance, when we turn a screw driver to produce torsion our hand applies torque ‘ T ’ to the handle and twists the shank of the screw driver.

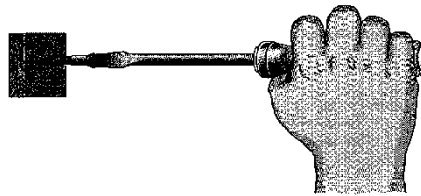

(a)



(b)

Bars subjected to Torsion

- ▶ Let us now consider a straight bar supported at one end and acted upon by two pairs of equal and opposite forces.

Then each pair of forces P_1 and P_2 form a couple that tend to twist the bar about its longitudinal axis, thus producing surface tractions and moments.

Then we can write the moments as

$$T_1 = P_1 d_1 \quad T_2 = P_2 d_2$$

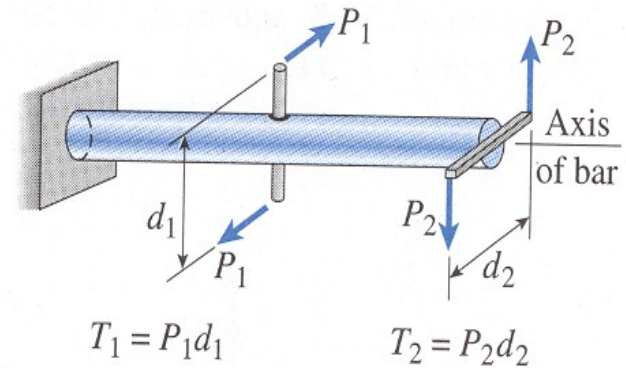

(a)

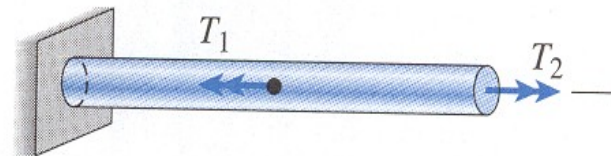

(b)

Torsion

- ▶ The moments that produce twisting of bar, such as T_1 and T_2 are called torques or twisting moments.
- ▶ The moments are indicated by the right hand rule for moment vectors, which states that if the fingers curl in the direction of the moments then the direction of the thumb represents the direction of vector.

Torsional Loads on Circular Shafts

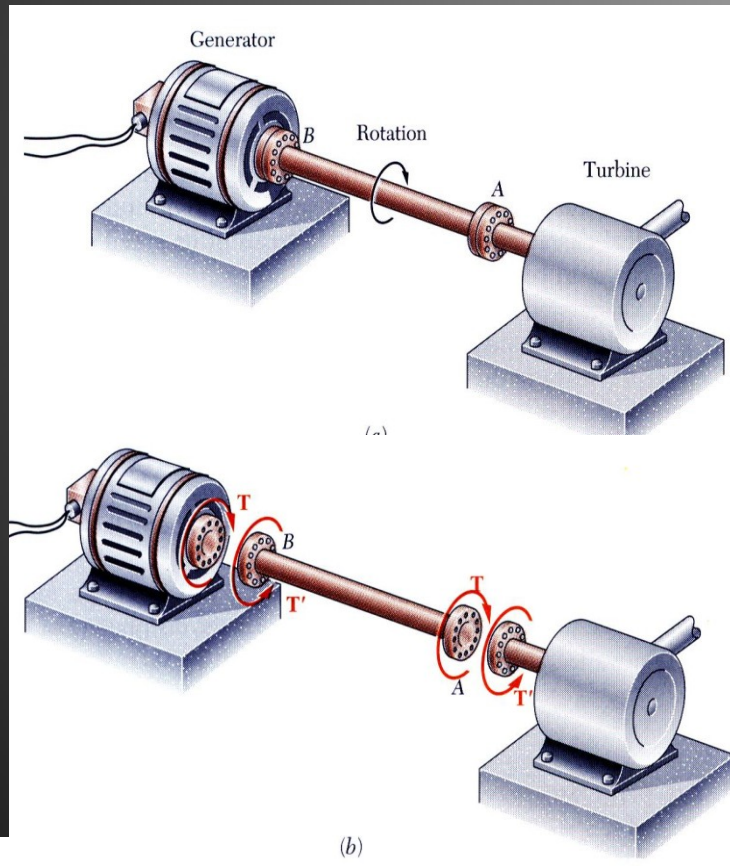

- ▶ Interested in stresses and strains of circular shafts subjected to twisting couples or torques.
- ▶ Turbine exerts torque T on the shaft.
- ▶ Shaft transmits the torque to the generator.
- ▶ Generator creates an equal and opposite torque T .

Net Torque Due to Internal Stresses

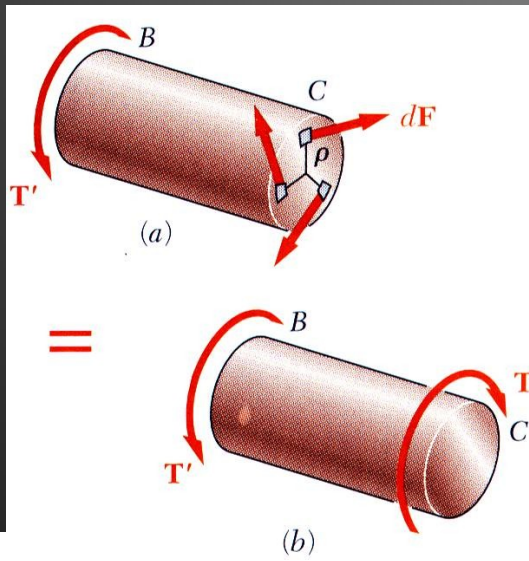
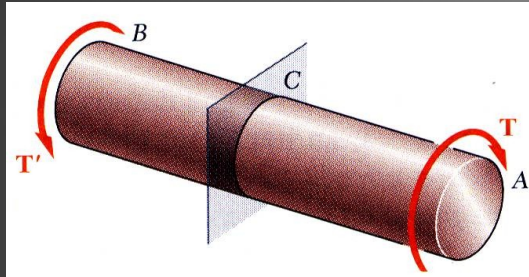

- ▶ Net of the internal shearing stresses is an internal torque, equal and opposite to the applied torque,

$$T = \int \rho dF = \int \rho (\tau dA)$$

- ▶ Although the net torque due to the shearing stresses is known, the distribution of the stresses is not.
- ▶ Distribution of shearing stresses is statically indeterminate – must consider shaft deformations.
- ▶ Unlike the normal stress due to axial loads, the distribution of shearing stresses due to torsional loads can not be assumed uniform.

Axial Shear Components

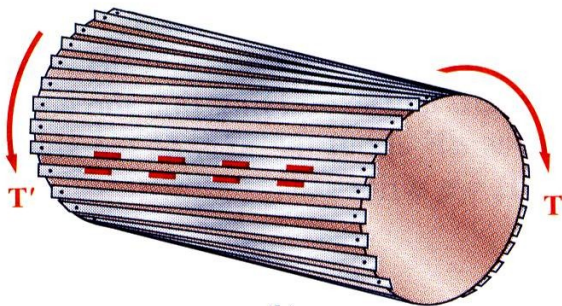
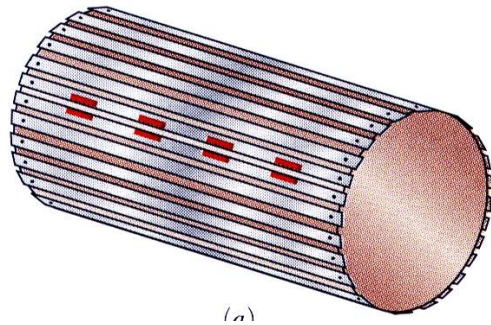
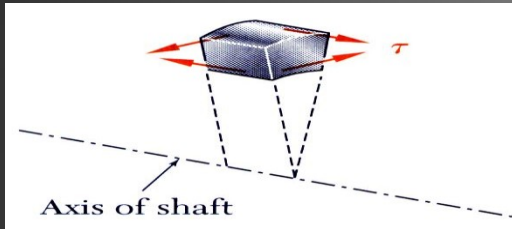

- ▶ Torque applied to shaft produces shearing stresses on the faces perpendicular to the axis.
- ▶ Conditions of equilibrium require the existence of equal stresses on the faces of the two planes containing the axis of the shaft.
- ▶ The existence of the axial shear components is demonstrated by considering a shaft made up of axial slats.
- ▶ The slats slide with respect to each other when equal and opposite torques are applied to the ends of the shaft.

Shaft Deformations

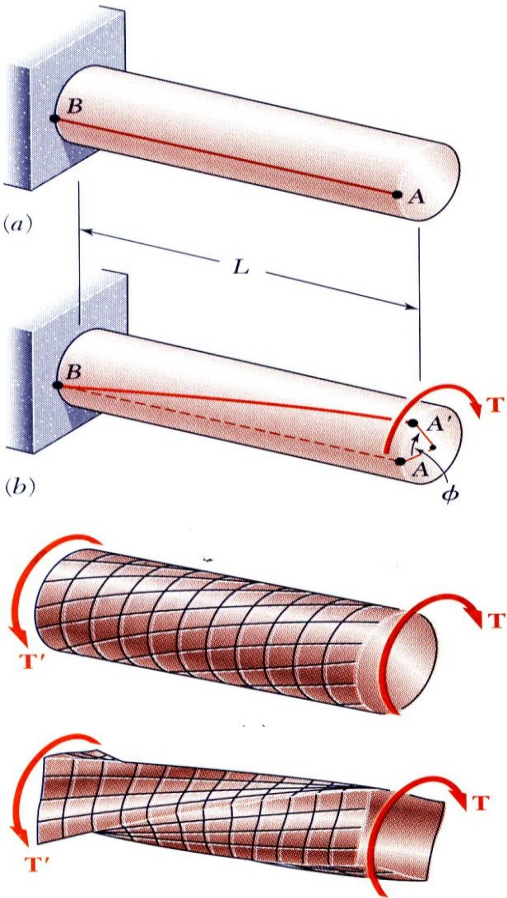

- ▶ From observation, the angle of twist of the shaft is proportional to the applied torque and to the shaft length.
$$\phi \propto T$$
$$\phi \propto L$$
- ▶ When subjected to torsion, every cross-section of a circular shaft remains plane and undistorted then the bar is said to be under pure torsion.
- ▶ Cross-sections for hollow and solid circular shafts remain plain and undistorted because a circular shaft is axisymmetric.
- ▶ Cross-sections of noncircular (non-axisymmetric) shafts are distorted when subjected to torsion.

Torsional deformation of circular shaft

- ▶ Consider a cylindrical bar of circular cross section twisted by the torques T at both the ends.
- ▶ Since every cross section of the bar is symmetrical and is applied to the same internal torque T we say that the bar is in pure torsion.
- ▶ Under action of torque T the right end of the bar will rotate through small angle ϕ known as angle of twist.
- ▶ The angle of twist varies along the axis of the bar at intermediate cross section denoted by $\phi(x)$.

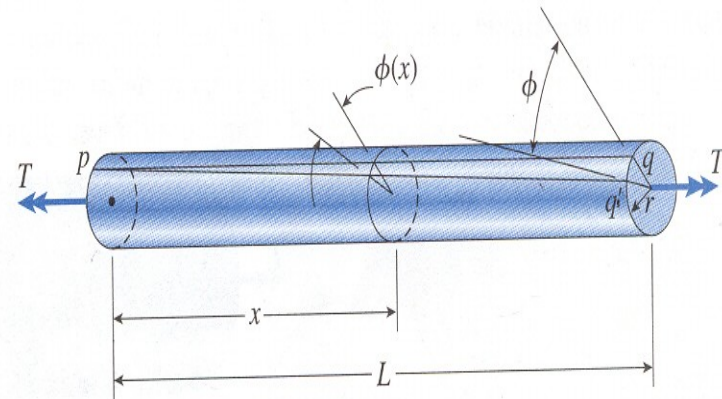

Torsional Deformations of a Circular Bar

- ▶ Rate of twist

$$\theta = \frac{d\phi}{dx}$$

- ▶ Shear Strain at the outer surface of the bar

$$\gamma_{\max} = \frac{bb'}{ab} = \frac{rd\phi}{dx} = r\theta$$

- ▶ For pure torsion the rate of twist is constant and equal to the total angle ϕ of twist divided by the length L of the bar

$$\gamma_{\max} = r\theta = \frac{r\phi}{L}$$

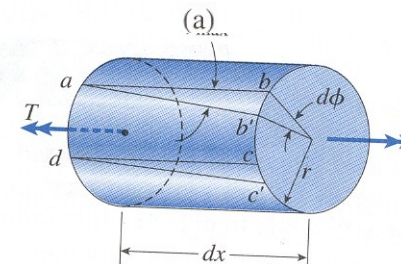
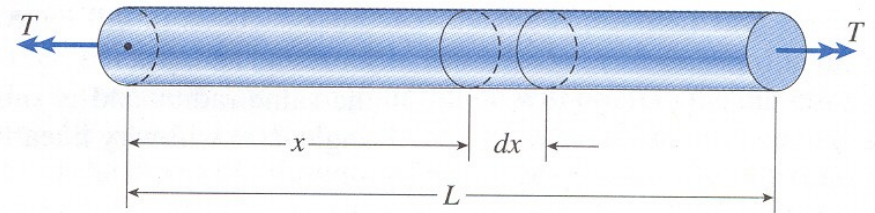

For Linear Elastic Materials

From Hooke's Law

$$\tau = G \gamma$$

G is shear modulus of elasticity
is shear strain

From Shear Strain equation :

$$\gamma_{\max} = r\theta = \frac{r\phi}{L}$$

- ▶ Shear Stress at the outer surface of the bar :

$$\tau_{\max} = G r \theta$$

- ▶ Torsion Formula : To determine the relation between shear stresses and torque, torsional formula is to be accomplished.

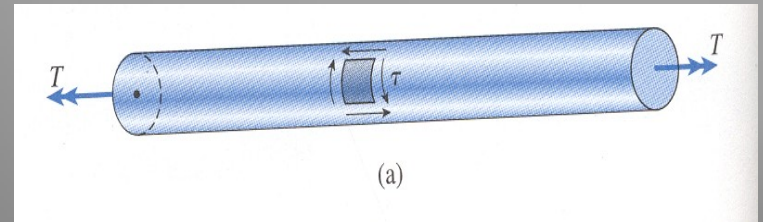

Shear Stresses in cylindrical bar with circular cross section.

Torsional Formula

- ▶ Since the stresses act continuously they have a resultant in the form of moment.

The Moment of a small element dA located at radial distance ρ and is given by

$$dM = \frac{\tau_{\max}}{r} \rho^2 dA$$

The resultant moment (torque T) is the summation over the entire cross sectional area of all such elemental moments.

$$T = \int_A dM = \frac{\tau_{\max}}{r} \int_A \rho^2 dA = \frac{\tau_{\max}}{r} I_p$$

Polar moment of inertia of circle with radius r and diameter d

$$I_p = \frac{\pi r^4}{2} = \frac{\pi d^4}{32}$$

Maximum Shear Stress

$$\tau_{\max} = \frac{Tr}{I_p} = \frac{16T}{\pi d^3}$$

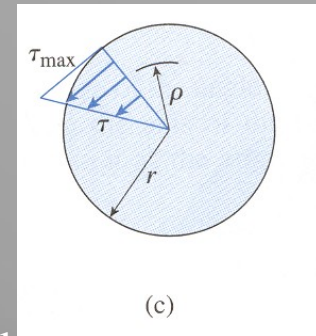

Distribution of stresses acting on a cross section.

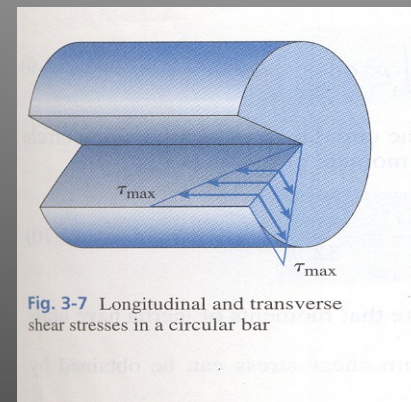

Fig. 3-7 Longitudinal and transverse shear stresses in a circular bar

Example from “Mechanics of Materials” by Gere & Timoshenko

- ▶ A solid steel bar of circular cross section has diameter $d=1.5\text{in}$, $l=54\text{in}$, $G=11.5 \times 10^6$ psi. The bar is subjected to torques T acting at the ends if the torques have magnitude $T=250$ lbft
- a) what is the maximum shear stress in the bar b) what is the angle of twist between the ends?

Solution

a) From torsional formula

$$\tau_{\max} = \frac{16T}{\pi d^3} = \frac{16 \cdot 250 \cdot 12}{\pi \cdot 1.5^3} = 4530 \text{ psi}$$

b) Angle of twist

$$I_p = \frac{\pi d^4}{32} = \frac{\pi \cdot 1.5^4}{32} = .4970 \text{ in}^4$$

$$\phi = \frac{TL}{GI_p} = \frac{250 \cdot 12 \cdot 54}{11.5 \cdot 10^6}$$

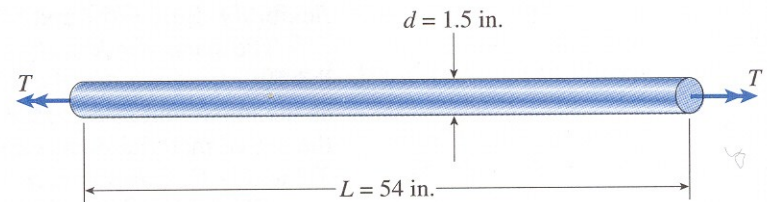

Stress and Strain Analysis

- ▶ A shaft of circular cross section subjected to torques at opposite ends is considered .
- ▶ A point in the cross section at the coordinate x_3 will be rotated at an angle

$$\theta x_3$$

- ▶ The displacements are given by $u_1 = -\theta x_2 x_3$ $u_2 = \theta x_1 x_3$

and $u_3 = 0$. Since θ is zero in x_3 direction.

- ▶ Components of strain tensor by using

$$\epsilon_{ik} = \frac{1}{2} (\partial u_i / \partial x_k + \partial u_k / \partial x_i)$$

we have

$$\epsilon_{ij} = \begin{bmatrix} 0 & 0 & \frac{-\theta x_2}{2} \\ 0 & 0 & \frac{\theta x_1}{2} \\ \frac{-\theta x_2}{2} & \frac{\theta x_1}{2} & 0 \end{bmatrix}$$

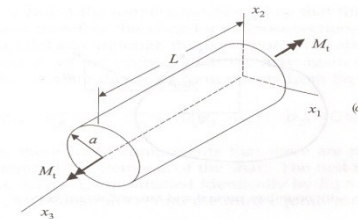

- $\epsilon_{ii} = 0$: Torsion does not result in the change in volume it implies pure shear deformation.

Stress and Strain Analysis

- ▶ From Hooke's Law we have

$$\sigma_{ij} = \lambda \delta_{ij} \epsilon_{kk} + 2\mu \epsilon_{ij}$$

where λ & μ are Lamé's Constant.

And $\mu = G$ where G is modulus of rigidity.

- ▶ Components of stress tensor

$$\sigma_{ij} = \begin{bmatrix} 0 & 0 & -G\theta x_2 \\ 0 & 0 & G\theta x_1 \\ -G\theta x_2 & G\theta x_1 & 0 \end{bmatrix}$$

Example from “Continuum Mechanics” by Batra

Given the displacement components

Find the strain tensor and stress tensor at the material point (0,1,1) where

$$u_1 = 2x_2^2 + x_2x_3 \quad u_2 = x_3^3 \quad u_3 = 0$$

Solution $G=11.5 \cdot 10^6 \text{ psi}$

We know the strain tensor is given by

$$\epsilon_{ij} = \begin{bmatrix} 0 & \frac{4x_2 + x_2}{2} & \frac{x_2}{2} \\ \frac{4x_2 + x_2}{2} & 0 & x_3 \\ \frac{x_2}{2} & x_3 & 0 \end{bmatrix}$$

at point (0,1,1)

$$\epsilon_{ik} = \frac{1}{2} (\partial u_i / \partial u_k + \partial u_k / \partial x_i)$$
$$\epsilon_{ij} = \begin{bmatrix} 0 & 2.5 & .5 \\ .5 & 0 & 1 \\ .5 & 1 & 0 \end{bmatrix}$$

Example from “Continuum Mechanics” by Batra

- ▶ From Hooke’s Law we have $\sigma_{ij} = \lambda \delta_{ij} \epsilon_{kk} + 2\mu \epsilon_{ij}$

$$\sigma_{ij} = G \epsilon_{ij}$$

$$\sigma_{ij} = \begin{bmatrix} 0 & 2.5 & .5 \\ .5 & 0 & 1 \\ .5 & 1 & 0 \end{bmatrix} 11.5 * 10^6$$

Conclusion

- ▶ The equations derived in this section are limited to bars of circular cross section solid that behave in linear elastic manner or loads must be such that the stresses do not exceed the proportional limit of the material.
- ▶ It can be emphasized that the equations for the torsion of circular cylinder cannot be used for non circular bars.

Homework Problem

Given the displacement components

$$u_1 = 2x_2 + x_3^3$$
$$u_2 = x_1^2 - x_3^2$$
$$u_3 = 0$$

Find the strain tensor and stress tensor at the material point (0,0,1) where $G=11.5 \cdot 10^6 \text{ psi}$