

VAPOR AND COMBINED POWER CYCLES

THE CARNOT VAPOR CYCLE

The Carnot cycle is the most efficient cycle operating between two specified temperature limits but it is not a suitable model for power cycles. Because:

Process 1-2 Limiting the heat transfer processes to two-phase systems severely limits the maximum temperature that can be used in the cycle (374°C for water)

Process 2-3 The turbine cannot handle steam with a high moisture content because of the impingement of liquid droplets on the turbine blades causing erosion and wear.

Process 4-1 It is not practical to design a compressor that handles two phases.

The cycle in (b) is not suitable since it requires isentropic compression to extremely high pressures and isothermal heat transfer at variable pressures.

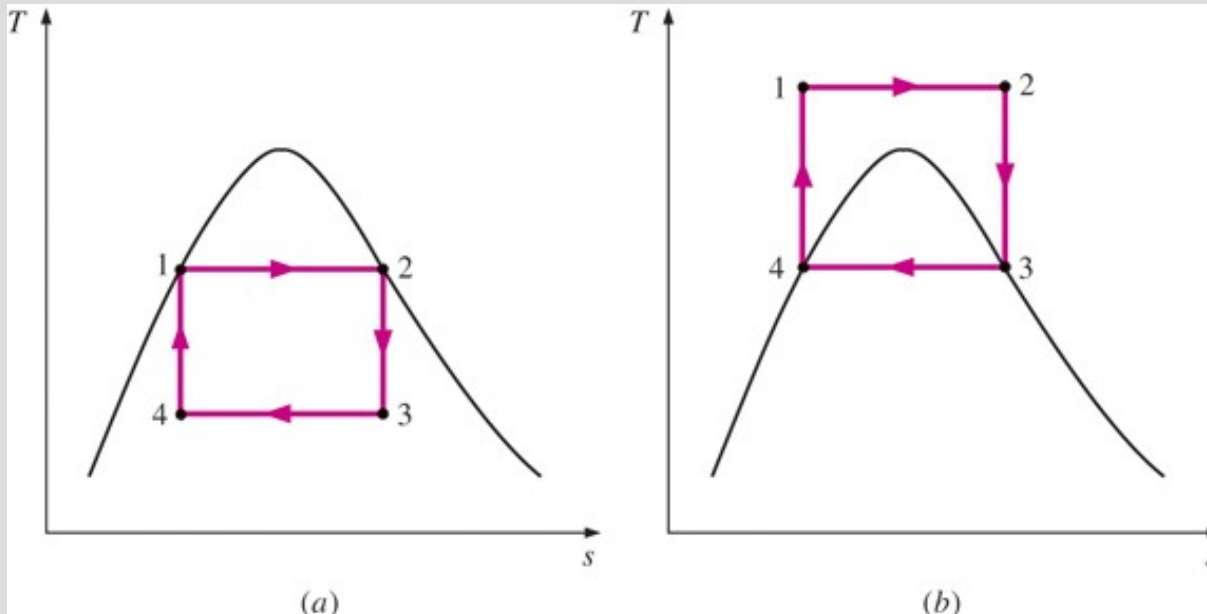

1-2 isothermal heat addition in a boiler
2-3 isentropic expansion in a turbine
3-4 isothermal heat rejection in a condenser
4-1 isentropic compression in a compressor

T-s diagram of two Carnot vapor cycles.

RANKINE CYCLE: THE IDEAL CYCLE FOR VAPOR POWER CYCLES

Many of the impracticalities associated with the Carnot cycle can be eliminated by superheating the steam in the boiler and condensing it completely in the condenser. The cycle that results is the **Rankine cycle**, which is the ideal cycle for vapor power plants. The ideal Rankine cycle does not involve any internal irreversibilities.

- 1-2 Isentropic compression in a pump
- 2-3 Constant pressure heat addition in a boiler
- 3-4 Isentropic expansion in a turbine
- 4-1 Constant pressure heat rejection in a condenser

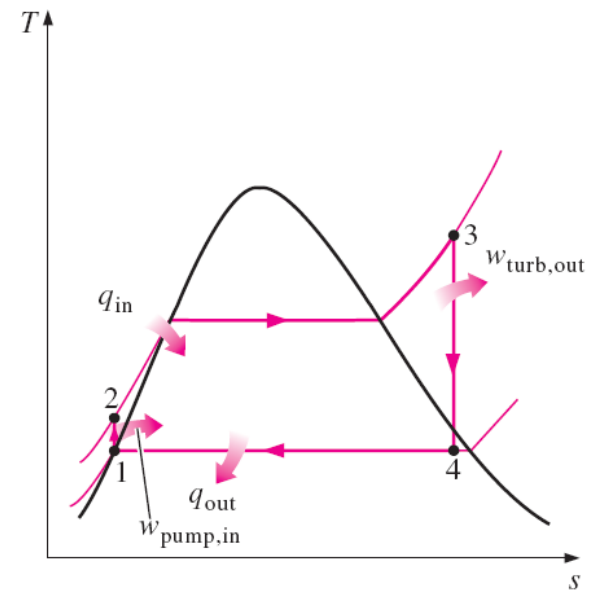
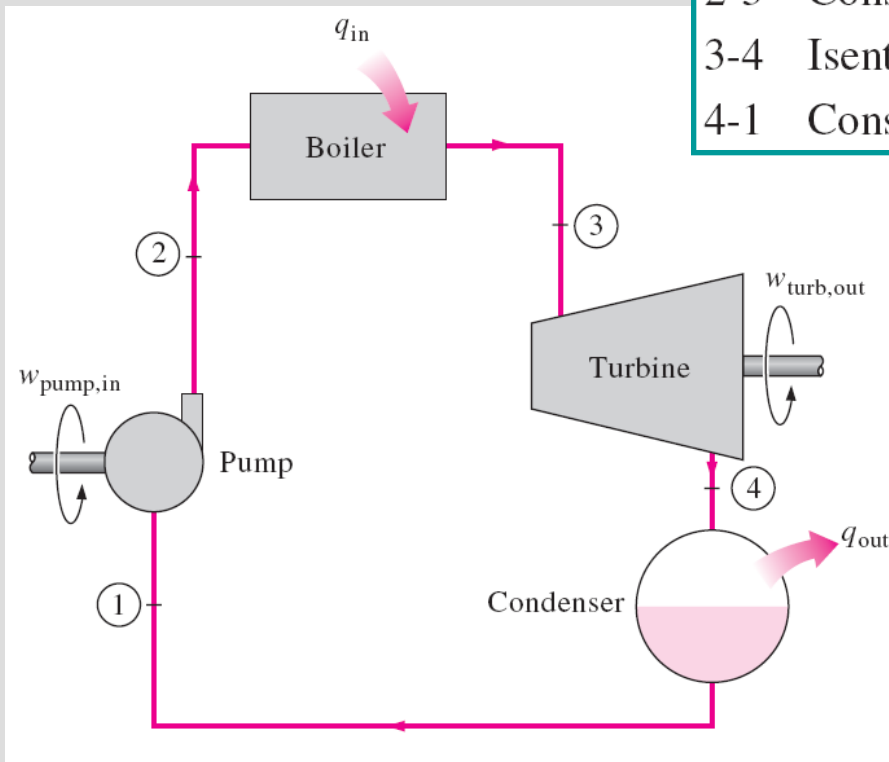

The simple ideal Rankine cycle.

Energy Analysis of the Ideal Rankine Cycle

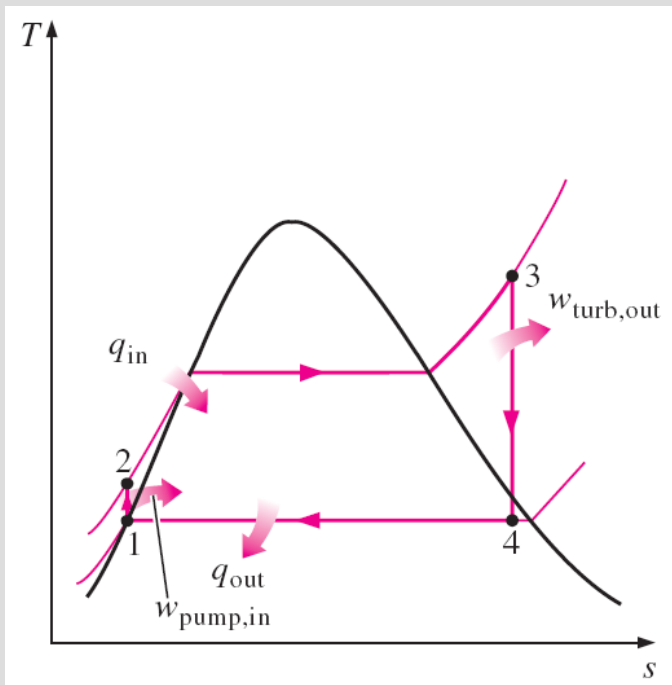

The efficiency of power plants in the U.S. is often expressed in terms of **heat rate**, which is the amount of heat supplied, in Btu's, to generate 1 kWh of electricity.

$$\eta_{th} = \frac{3412 \text{ (Btu/kWh)}}{\text{Heat rate (Btu/kWh)}}$$

Steady-flow energy equation

$$(q_{in} - q_{out}) + (w_{in} - w_{out}) = h_e - h_i \quad (\text{kJ/kg})$$

Pump ($q = 0$):

$$w_{\text{pump,in}} = h_2 - h_1$$

$$w_{\text{pump,in}} = v(P_2 - P_1)$$

$$h_1 = h_f @ P_1 \quad \text{and} \quad v \cong v_1 = v_f @ P_1$$

Boiler ($w = 0$):

$$q_{in} = h_3 - h_2$$

Turbine ($q = 0$):

$$w_{\text{turb,out}} = h_3 - h_4$$

Condenser ($w = 0$):

$$q_{out} = h_4 - h_1$$

$$w_{\text{net}} = q_{in} - q_{out} = w_{\text{turb,out}} - w_{\text{pump,in}}$$

$$\eta_{th} = \frac{w_{\text{net}}}{q_{in}} = 1 - \frac{q_{out}}{q_{in}}$$

The thermal efficiency can be interpreted as the ratio of the area enclosed by the cycle on a T - s diagram to the area under the heat-addition process.

DEVIATION OF ACTUAL VAPOR POWER CYCLES FROM IDEALIZED ONES

The actual vapor power cycle differs from the ideal Rankine cycle as a result of irreversibilities in various components.

Fluid friction and heat loss to the surroundings are the two common sources of irreversibilities.

Isentropic efficiencies

$$\eta_P = \frac{w_s}{w_a} = \frac{h_{2s} - h_1}{h_{2a} - h_1}$$

$$\eta_T = \frac{w_a}{w_s} = \frac{h_3 - h_{4a}}{h_3 - h_{4s}}$$

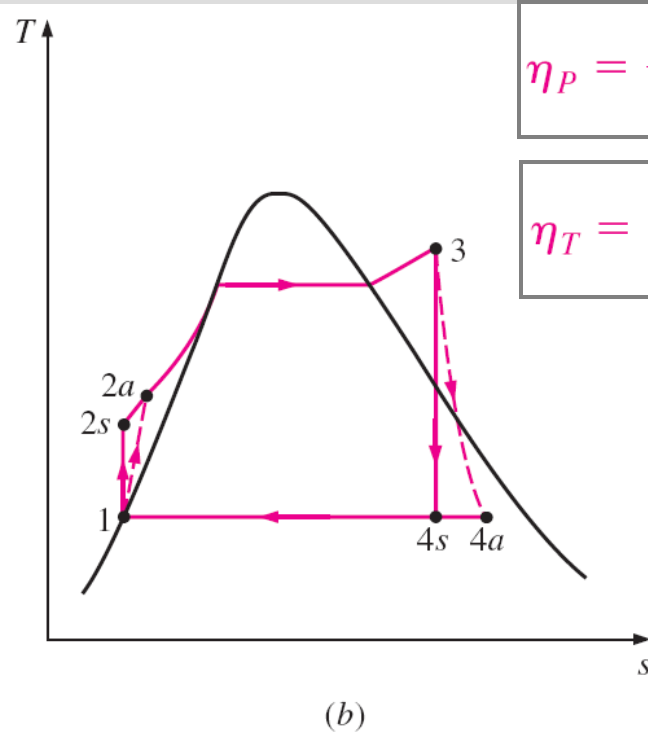
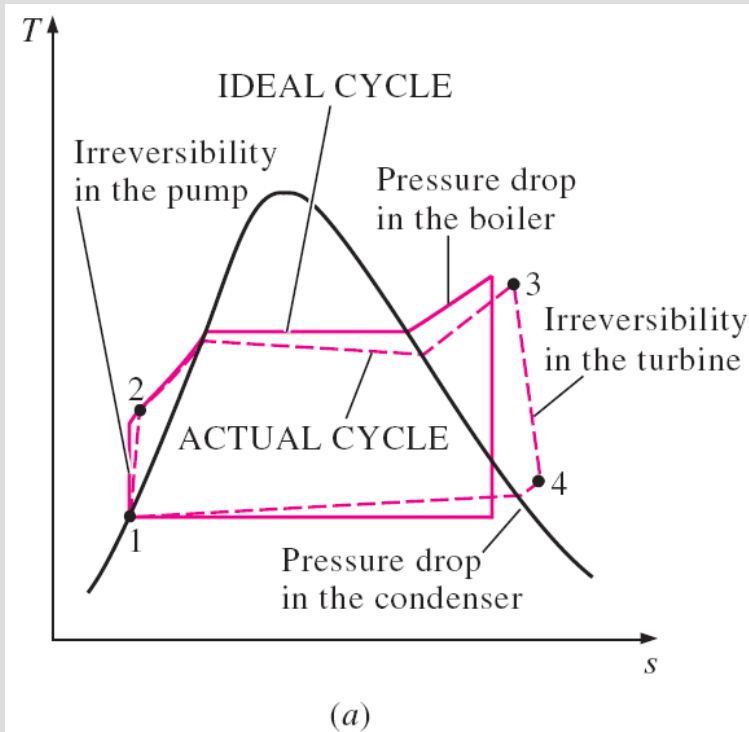

(a) Deviation of actual vapor power cycle from the ideal Rankine cycle.

(b) The effect of pump and turbine irreversibilities on the ideal Rankine cycle.

HOW CAN WE INCREASE THE EFFICIENCY OF THE RANKINE CYCLE?

The basic idea behind all the modifications to increase the thermal efficiency of a power cycle is the same: *Increase the average temperature at which heat is transferred to the working fluid in the boiler, or decrease the average temperature at which heat is rejected from the working fluid in the condenser.*

Lowering the Condenser Pressure (*Lowers $T_{\text{low,avg}}$*)

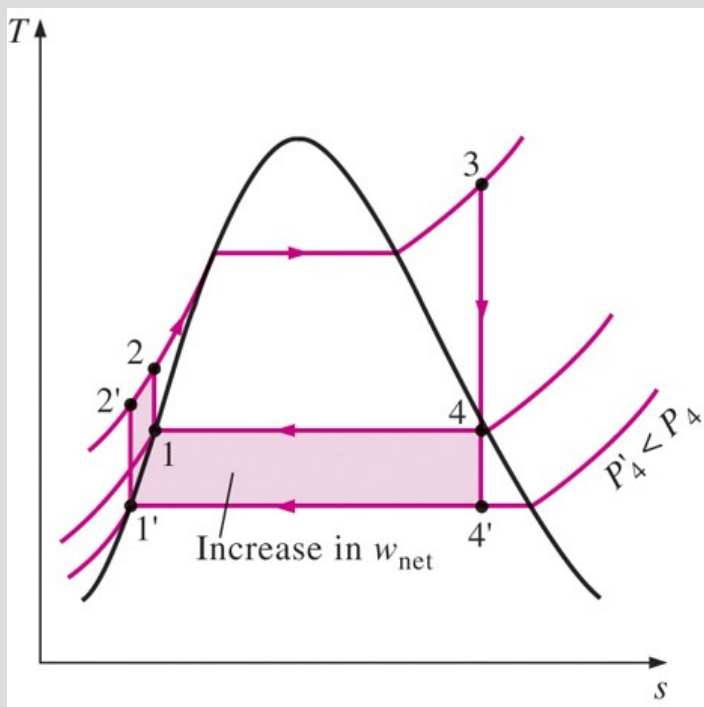

To take advantage of the increased efficiencies at low pressures, the condensers of steam power plants usually operate well below the atmospheric pressure. There is a lower limit to this pressure depending on the temperature of the cooling medium

Side effect: Lowering the condenser pressure increases the moisture content of the steam at the final stages of the turbine.

The effect of lowering the condenser pressure on the ideal Rankine cycle.

Superheating the Steam to High Temperatures (Increases $T_{\text{high,avg}}$)

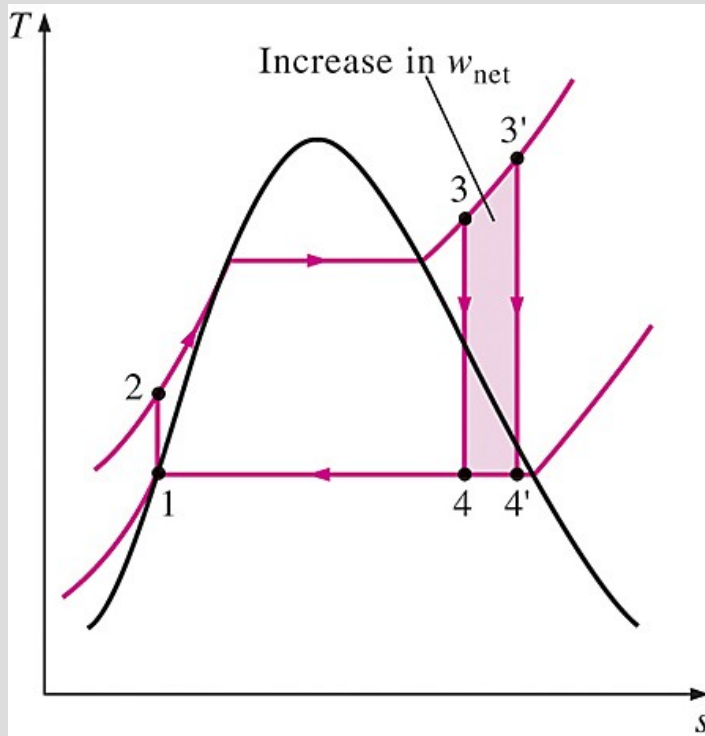

The effect of superheating the steam to higher temperatures on the ideal Rankine cycle.

Both the net work and heat input increase as a result of superheating the steam to a higher temperature. The overall effect is an increase in thermal efficiency since the average temperature at which heat is added increases.

Superheating to higher temperatures decreases the moisture content of the steam at the turbine exit, which is desirable.

The temperature is limited by metallurgical considerations. Presently the highest steam temperature allowed at the turbine inlet is about 620°C.

Increasing the Boiler Pressure (*Increases* $T_{\text{high,avg}}$)

For a fixed turbine inlet temperature, the cycle shifts to the left and the moisture content of steam at the turbine exit increases. This side effect can be corrected by reheating the steam.

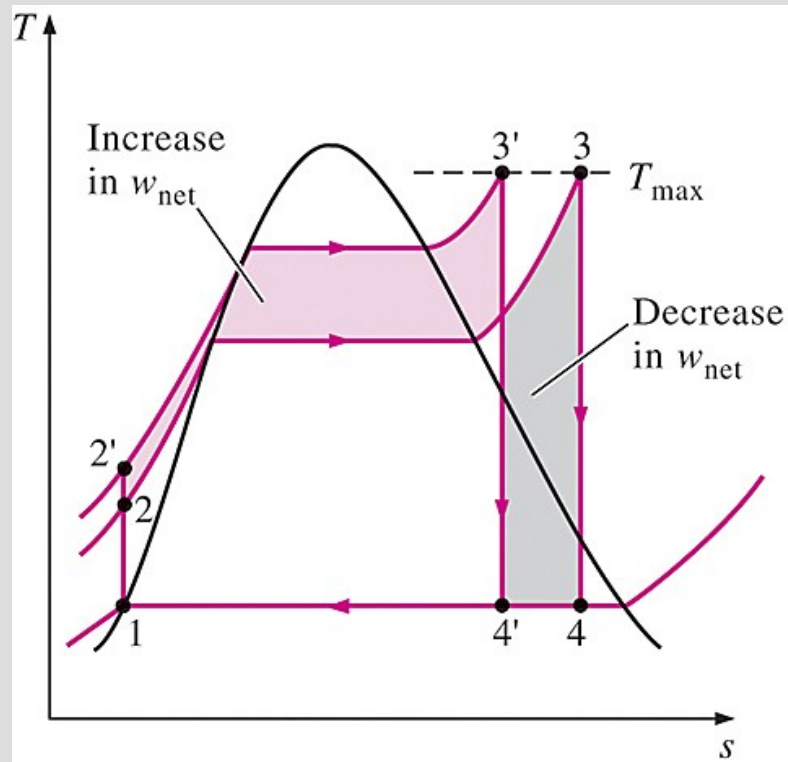

The effect of increasing the boiler pressure on the ideal Rankine cycle.

Today many modern steam power plants operate at supercritical pressures ($P > 22.06$ MPa) and have thermal efficiencies of about 40% for fossil-fuel plants and 34% for nuclear plants.

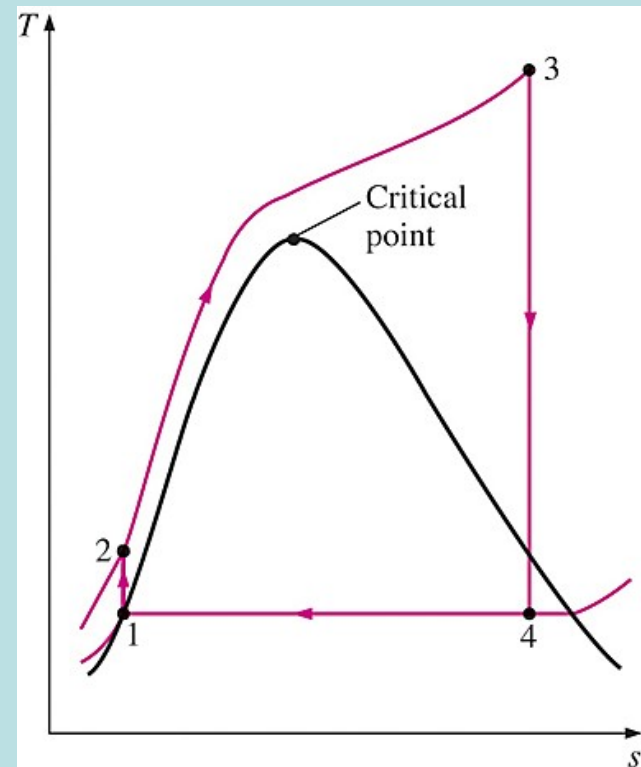

A supercritical Rankine cycle.

REHEAT RANKINE CYCLE

How can we take advantage of the increased efficiencies at higher boiler pressures without facing the problem of excessive moisture at the final stages of the turbine?

1. Superheat the steam to very high temperatures. It is limited metallurgically.
2. Expand the steam in the turbine in two stages, and reheat it in between (**reheat**)

$$q_{\text{in}} = q_{\text{primary}} + q_{\text{reheat}} = (h_3 - h_2) + (h_5 - h_4)$$

$$w_{\text{turb,out}} = w_{\text{turb,I}} + w_{\text{turb,II}} = (h_3 - h_4) + (h_5 - h_6)$$

The ideal reheat Rankine cycle.

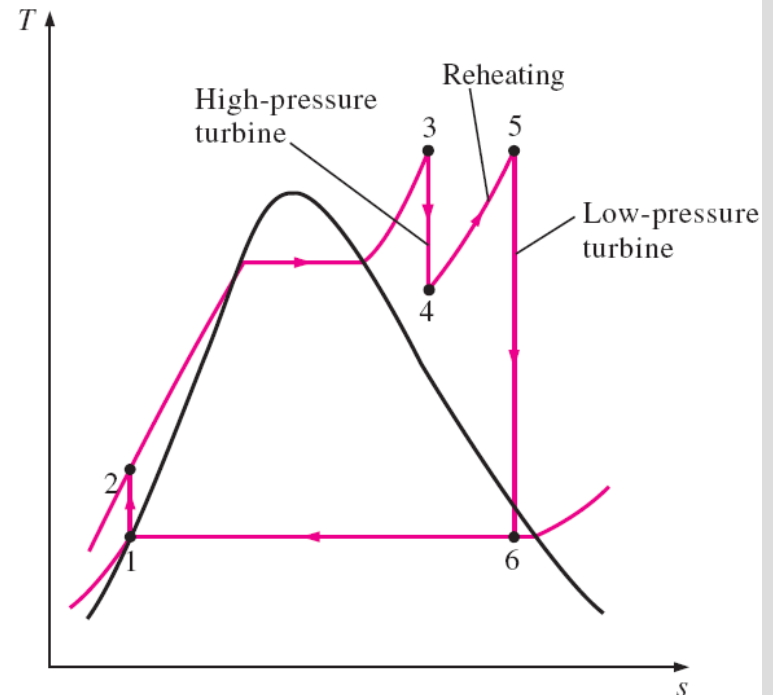
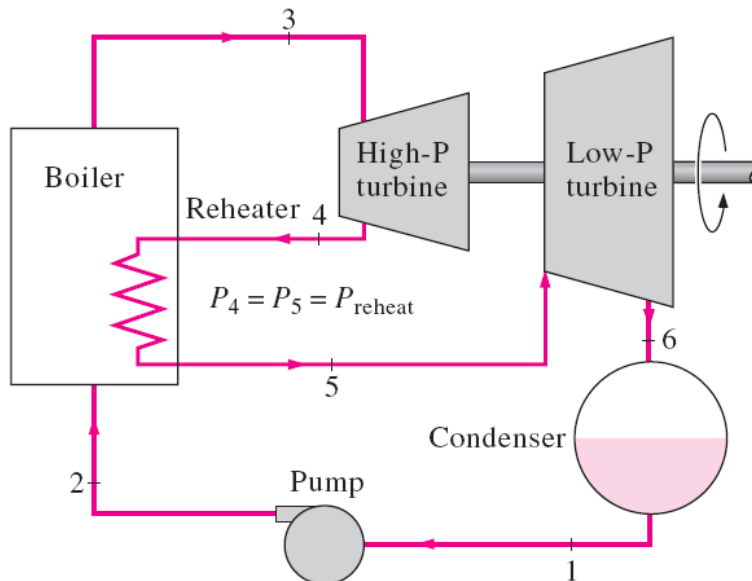

The single reheat in a modern power plant improves the cycle efficiency by 4 to 5% by increasing the average temperature at which heat is transferred to the steam.

The average temperature during the reheat process can be increased by increasing the number of expansion and reheat stages. As the number of stages is increased, the expansion and reheat processes approach an isothermal process at the maximum temperature. The use of more than two reheat stages is not practical. The theoretical improvement in efficiency from the second reheat is about half of that which results from a single reheat.

The reheat temperatures are very close or equal to the turbine inlet temperature.

The optimum reheat pressure is about one-fourth of the maximum cycle pressure.

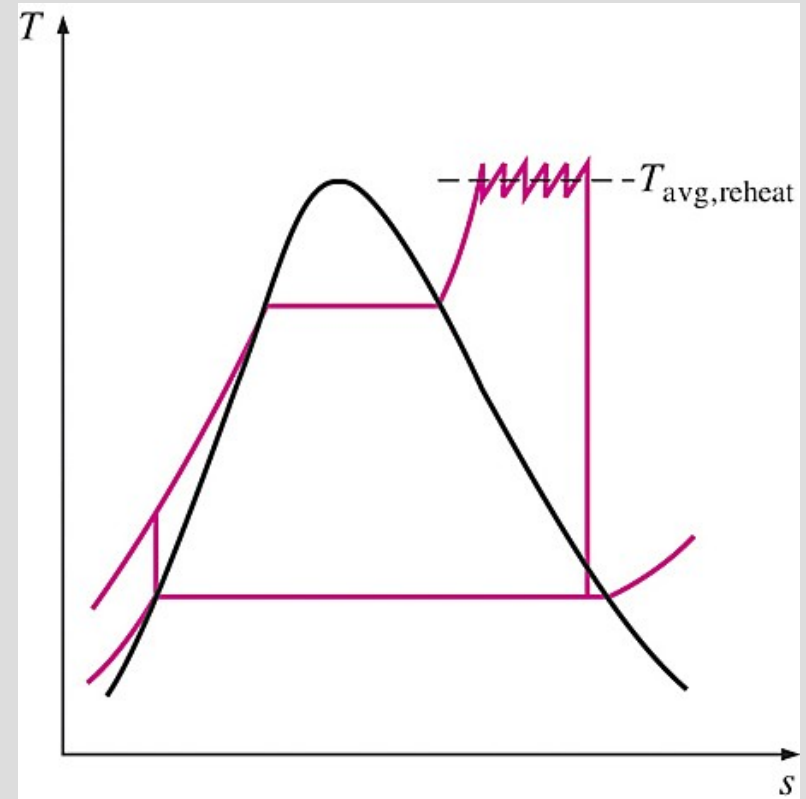

The average temperature at which heat is transferred during reheating increases as the number of reheat stages is increased.

REGENERATIVE RANKINE CYCLE

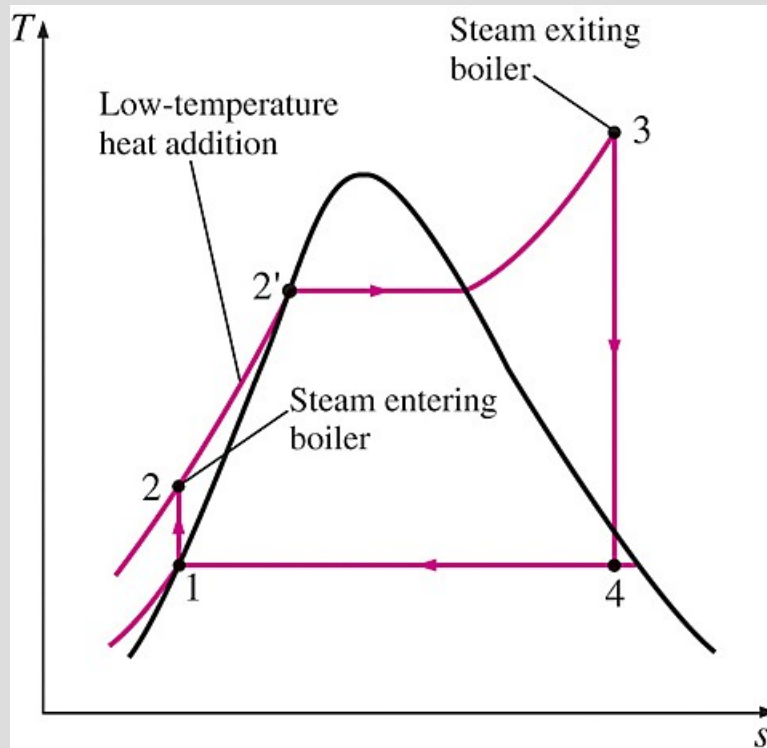

Heat is transferred to the working fluid during process 2-2' at a relatively low temperature. This lowers the average heat-addition temperature and thus the cycle efficiency.

In steam power plants, steam is extracted from the turbine at various points. This steam, which could have produced more work by expanding further in the turbine, is used to heat the feedwater instead. The device where the feedwater is heated by regeneration is called a **regenerator**, or a **feedwater heater (FWH)**.

The first part of the heat-addition process in the boiler takes place at relatively low temperatures.

A feedwater heater is basically a heat exchanger where heat is transferred from the steam to the feedwater either by mixing the two fluid streams (**open feedwater heaters**) or without mixing them (**closed feedwater heaters**).

Open Feedwater Heaters

An **open** (or **direct-contact**) **feedwater heater** is basically a *mixing chamber*, where the steam extracted from the turbine mixes with the feedwater exiting the pump. Ideally, the mixture leaves the heater as a saturated liquid at the heater pressure.

$$q_{in} = h_5 - h_4$$

$$q_{out} = (1 - y)(h_7 - h_1)$$

$$w_{turb,out} = (h_5 - h_6) + (1 - y)(h_6 - h_7)$$

$$w_{pump,in} = (1 - y)w_{pump\ I,in} + w_{pump\ II,in}$$

$$y = \dot{m}_6 / \dot{m}_5 \quad (\text{fraction of steam extracted})$$

$$w_{pump\ I,in} = v_1(P_2 - P_1)$$

$$w_{pump\ II,in} = v_3(P_4 - P_3)$$

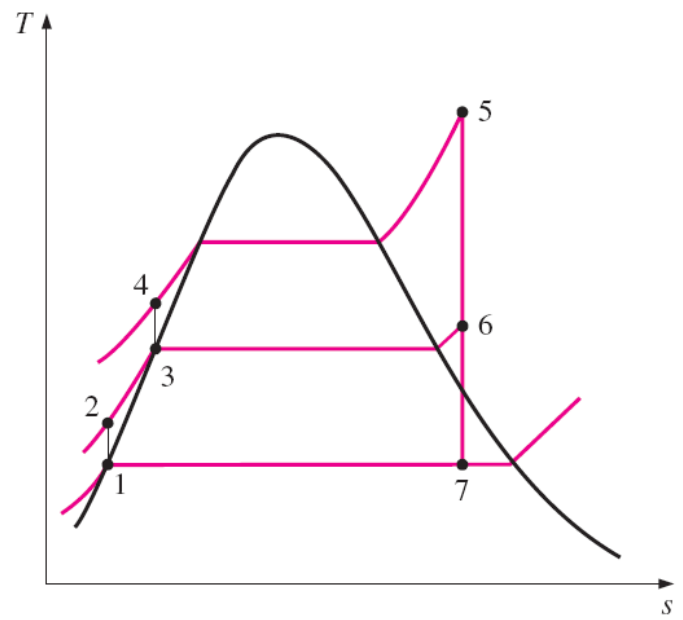
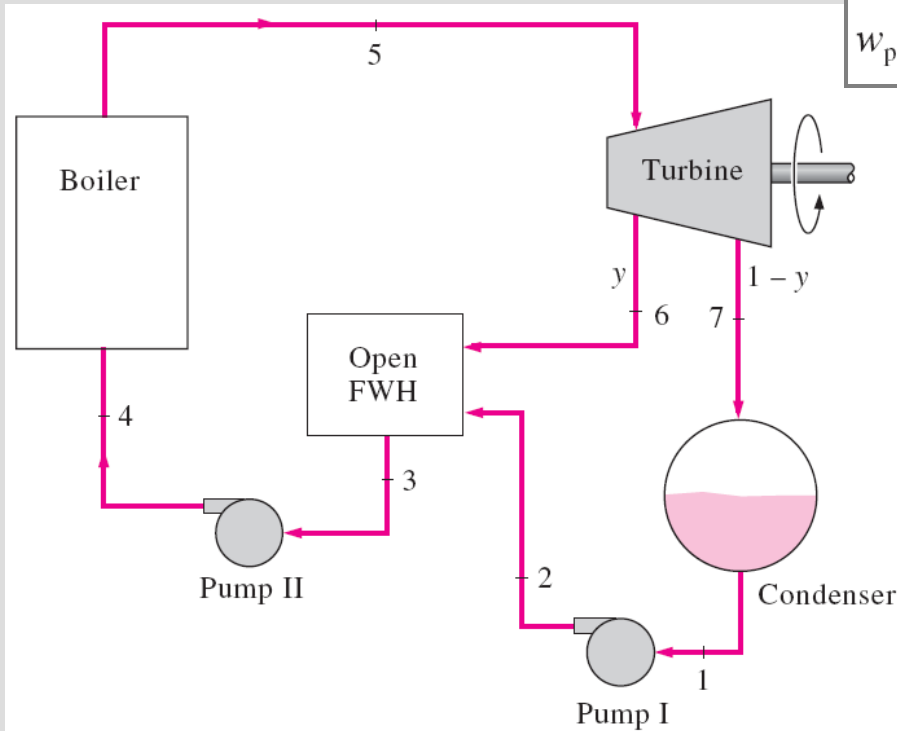

The ideal regenerative Rankine cycle with an open feedwater heater.

Closed Feedwater Heaters

Another type of feedwater heater frequently used in steam power plants is the **closed feedwater heater**, in which heat is transferred from the extracted steam to the feedwater without any mixing taking place. The two streams now can be at different pressures, since they do not mix.

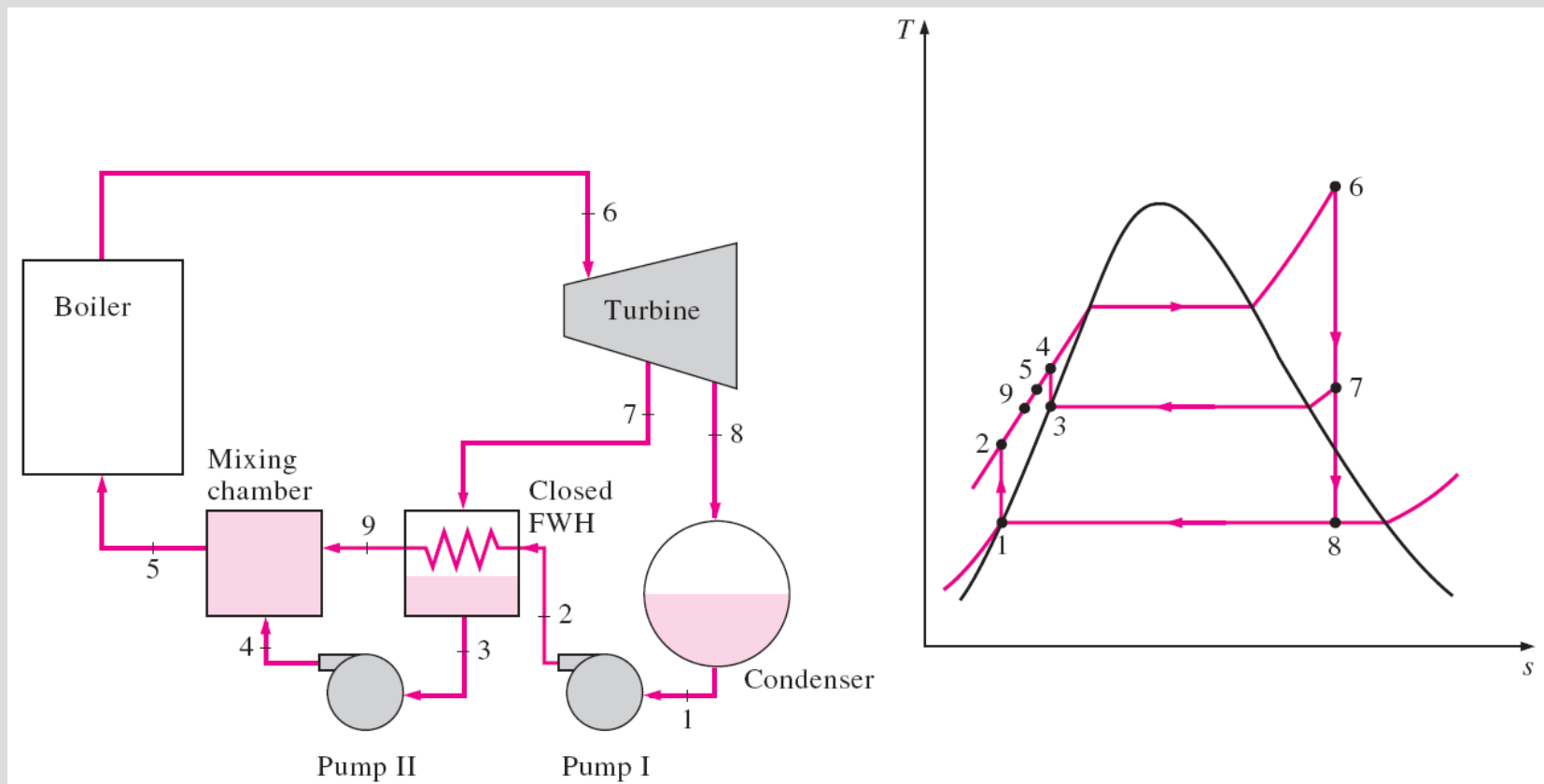

The ideal regenerative Rankine cycle with a closed feedwater heater.

The closed feedwater heaters are more complex because of the internal tubing network, and thus they are more expensive. Heat transfer in closed feedwater heaters is less effective since the two streams are not allowed to be in direct contact. However, closed feedwater heaters do not require a separate pump for each heater since the extracted steam and the feedwater can be at different pressures.

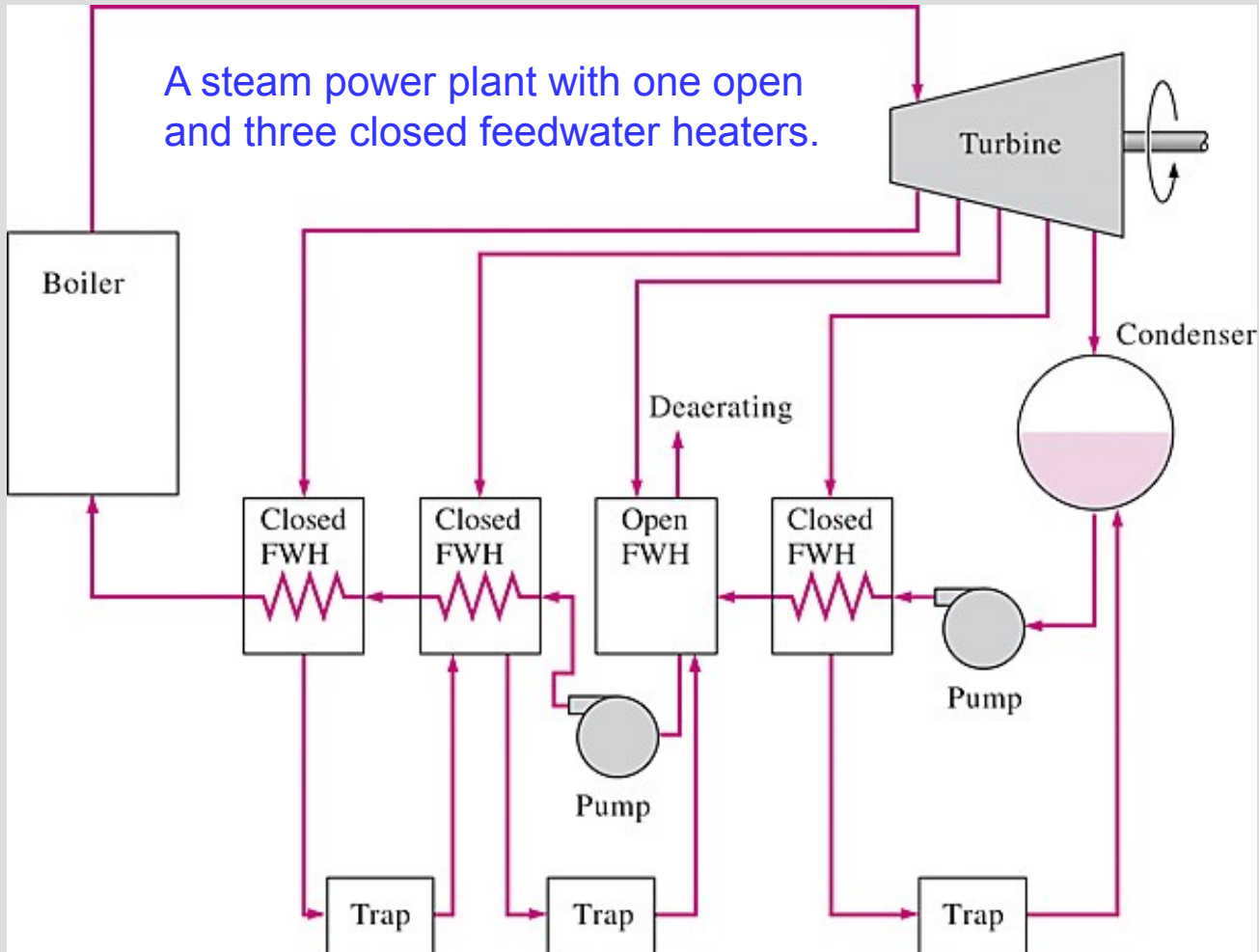

Open feedwater heaters are simple and inexpensive and have good heat transfer characteristics. For each heater, however, a pump is required to handle the feedwater.

Most steam power plants use a combination of open and closed feedwater heaters.