

INTRODUCTION

- ❑ The jigs and fixtures are the economical ways to produce a component in mass production system.
- ❑ These are special work holding and tool guiding device
- ❑ Quality of the performance of a process largely influenced by the quality of jigs and fixtures used for this purpose.
- ❑ The main purpose of a fixture is to locate and in the cases hold a work piece during an operation
- ❑ A jig differs from a fixture in the sense that it guides the tool to its correct position or towards its correct movement during an operation in addition to locating and supporting the work piece.

IMPORTANT CONSIDERATIONS WHILE DESIGNING JIGS AND FIXTURES

Designing of jigs and fixtures depends upon so many factors. These factors are analysed to get design inputs for jigs and fixtures

- (a) Study of work piece and finished component size and geometry.
- (b) Type and capacity of the machine, its extent of automation.
- (c) Provision of locating devices in the machine.
- (d) Available clamping arrangements in the machine.
- (e) Available indexing devices, their accuracy.
- (f) Evaluation of variability in the performance results of the machine.
- (g) Rigidity and of the machine tool under consideration.
- (h) Study of ejecting devices, safety devices, etc.
- (i) Required level of the accuracy in the work and quality to be produced.

Major elements of jig and fixtures

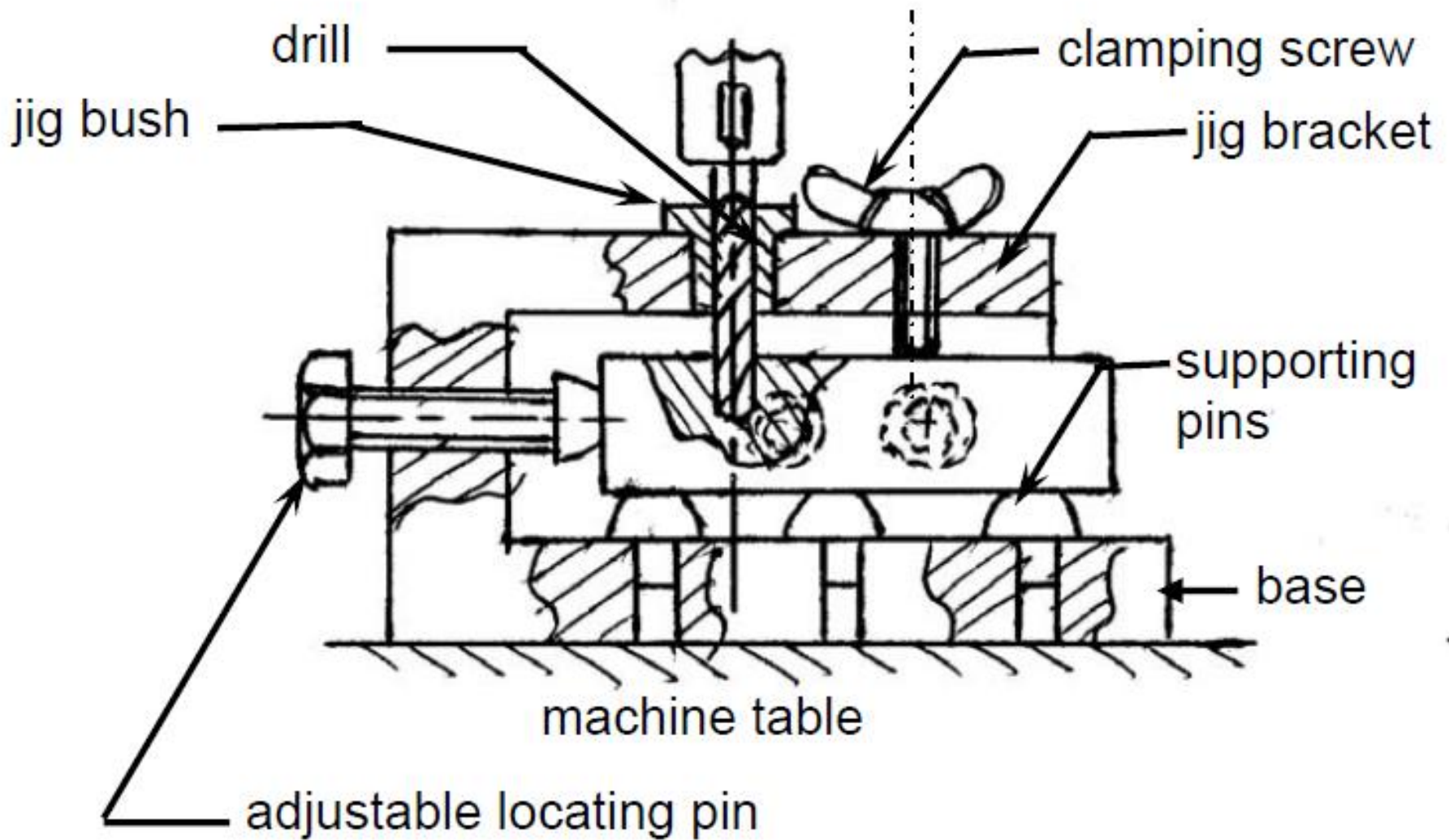

MEANING OF LOCATION

- The location refers to the establishment of a desired relationship between the work piece and the jigs or fixture correctness of location directly influences the accuracy of the finished product.
- The jigs and fixtures are desired so that all undesirable movements of the work piece can be restricted.
- Determination of the locating points and clamping of the work piece serve to restrict movements of the component in any direction, , while setting it in a particular pre-decided position relative to the jig.
- Before deciding the locating points it is advisable to find out the all possible degrees of freedom of the work piece.
- Then some of the degrees of freedom or all of them are restrained by making suitable arrangements.

Six Points Location of a Rectangular Block

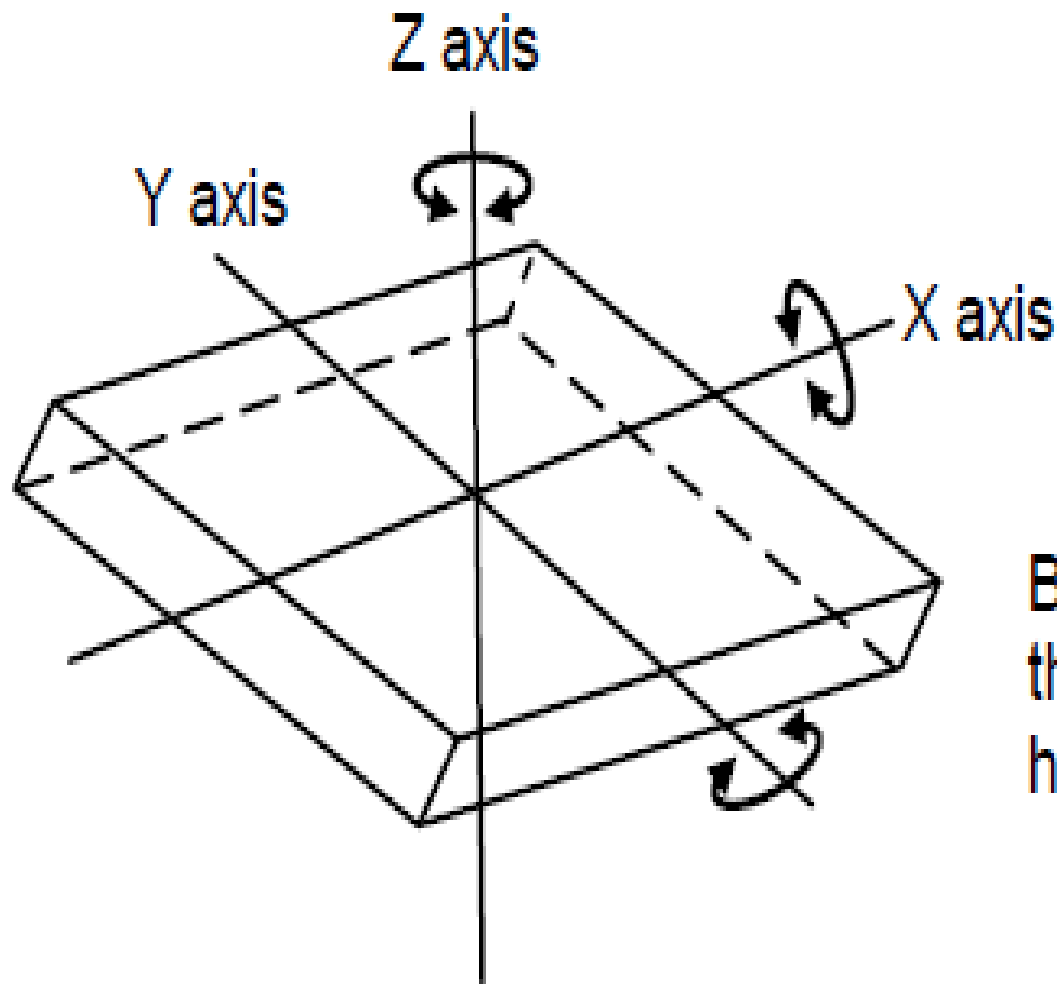

Body to be restrained (each of the axis can be divided into two halves positive and negative)

Figure 4.1 : Available Degree of Freedom of Rectangular Block

- ❑ Considering the six degree of freedom of a rectangular block as shown in Figure
- ❑ It is made to rest on several points on the jig body.
- ❑ Provide a rest to workpiece on three points on the bottom x - y surface.
- ❑ This will stop the movement along z -axis, rotation with respect to x -axis and y -axis.
- ❑ Supporting it on the three points is considered as better support than one point or two points
- ❑ Rest the workpiece on two points of side surface (x - z), this will fix the movement of workpiece along y -axis and rotation with respect to z -axis
- ❑ Provide a support at one point of the adjacent surface (y - z) that will fix other remaining free movements.

- This principle of location of fixing points on the workpiece is also named as 3-2-1 principle of fixture design as number of points selected at different faces of the workpiece are 3, 2 and 1 respectively.



DIFFERENT METHODS USED FOR LOCATION

- ❑ There are different methods used for location of a work
 - ❑ The locating arrangement should be decided after studying the type of work, type of operation, degree of accuracy required.
 - ❑ Volume of mass production to be done also matters a lot
 - ❑ Different locating methods are described below.
-
- ❑ **Flat Locator :**
 - ❑ Flat locators are used for location of flat machined surfaces of the component
 - ❑ Three different examples which can be served as a general principle of location are described here for flat locators

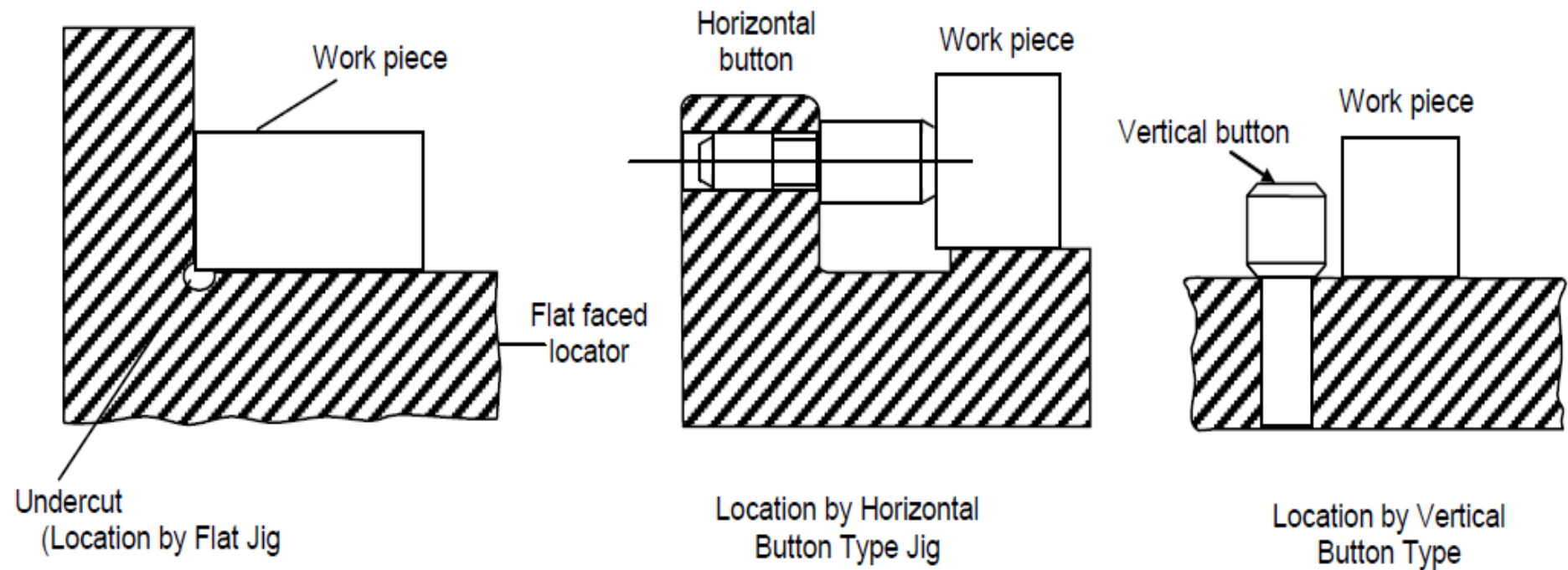

Figure 4.3 : Method of Locating using Flat Locators

- ❑ A flat surface locator can be used as shown in first figure
- ❑ In this case an undercut is provided at the bottom where two perpendicular surfaces intersect each other.
- ❑ This is made for swarf clearance.
- ❑ The middle figure shows flat headed button type locator.
- ❑ There is no need to made undercut for swarf clearance.
- ❑ The button can be adjusted to decide very fine location of the workpiece.
- ❑ There can be a vertical button support as shown in third figure, which is a better arrangement due to its capacity to bear end load

Cylindrical Locators

- ❑ A cylindrical locator is shown in Figure.
- ❑ It is used for locating components having drilled holes.
- ❑ The cylindrical component to be located is gripped by a cylindrical locator fitted to the jig's body and inserted in the drilled hole of the component.
- ❑ The face of the jig is ground to provide space for swarf clearance.

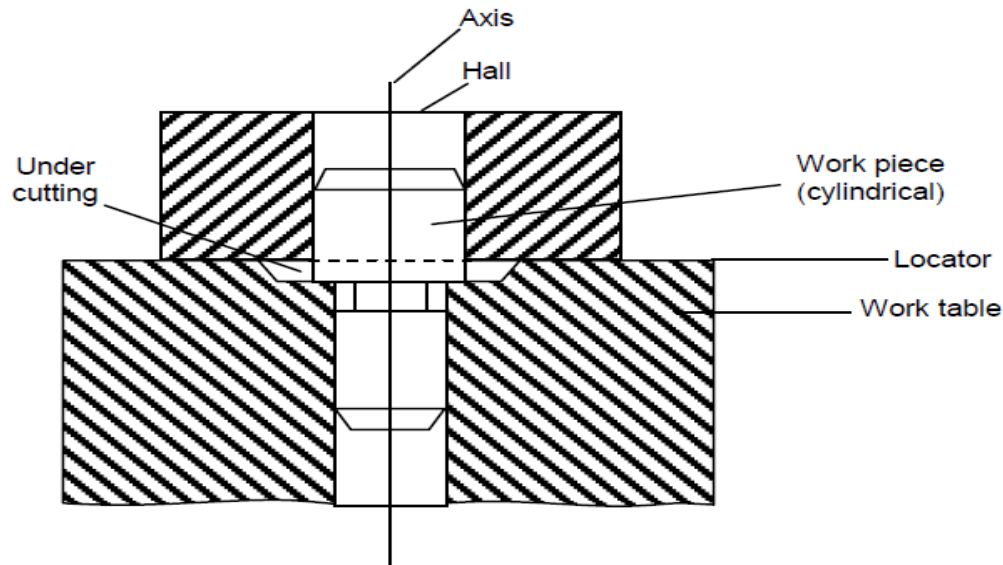

Figure 4.4 : Cylindrical Locator

Conical Locator

- ❑ A conical locator is illustrated in Figure 4.5.
- ❑ This is used for locating the workpieces having cylindrical hole in the workpiece. The workpiece is found located by supporting it over the conical locator inserted into the drilled hole of the workpiece.
- ❑ A conical locator is considered as superior as it has a capacity to accommodate a slight variation in the hole diameter of the component without affecting the accuracy of location.
- ❑ Degree of freedom along z-axis can also be restrained by putting a template over the workpiece with the help of screws.

Conical Locator

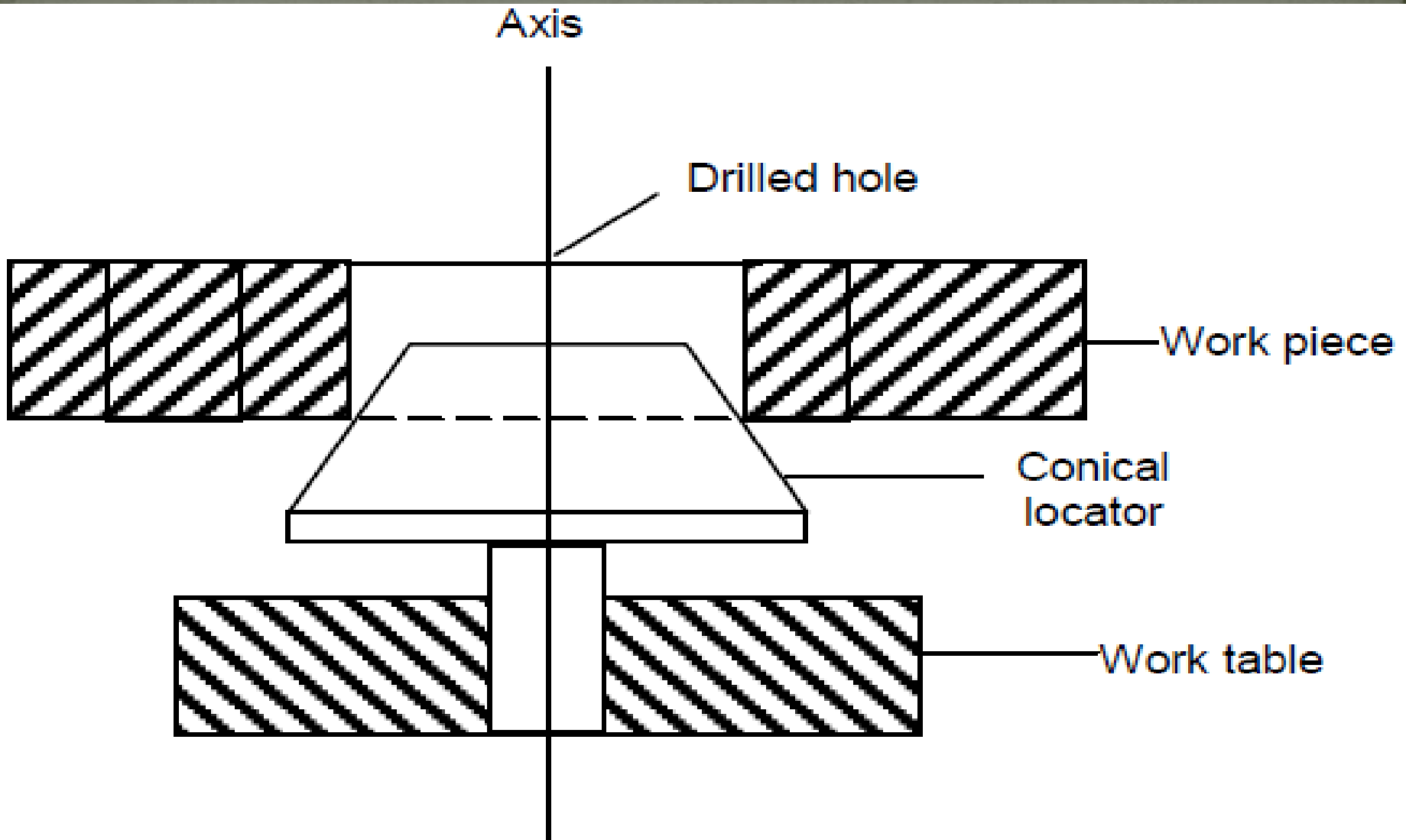
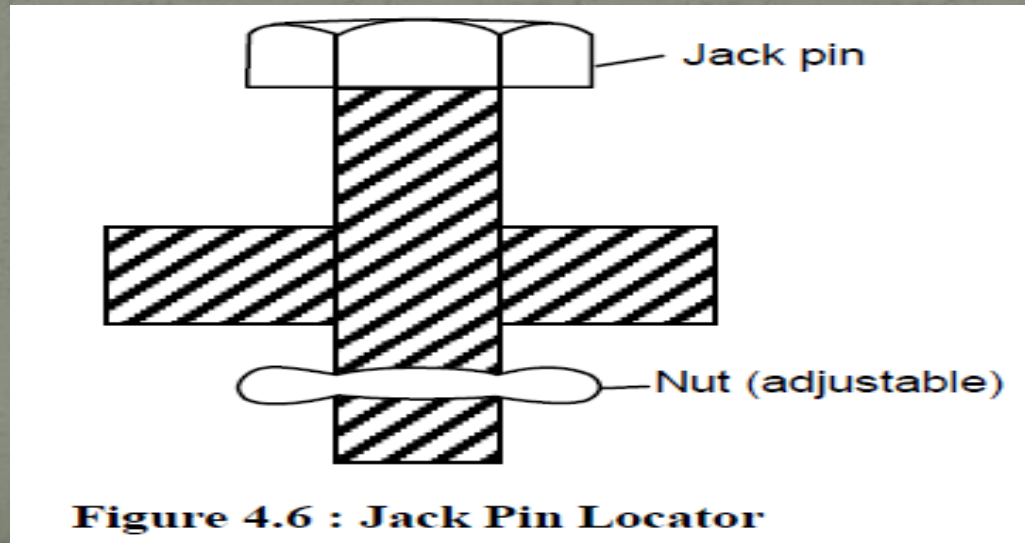

Figure 4.5 : Conical Locator

Jack Pin Locator

- ❑ Jack pin locator is used for supporting rough workpieces from the bottom as shown in Figure .
- ❑ Height of the jack pin is adjustable to accommodate the workpieces having variation in their surface texture.
- ❑ So this is a suitable method to accommodate the components which are rough and un-machined.



Drill Bush Locator

- ❑ The drill bush locator is illustrated in Figure.
- ❑ It is used for holding and locating the cylindrical work pieces.
- ❑ The bush has conical opening for locating purpose and it is sometimes screwed on the jig's body for the adjustment of height of the work.

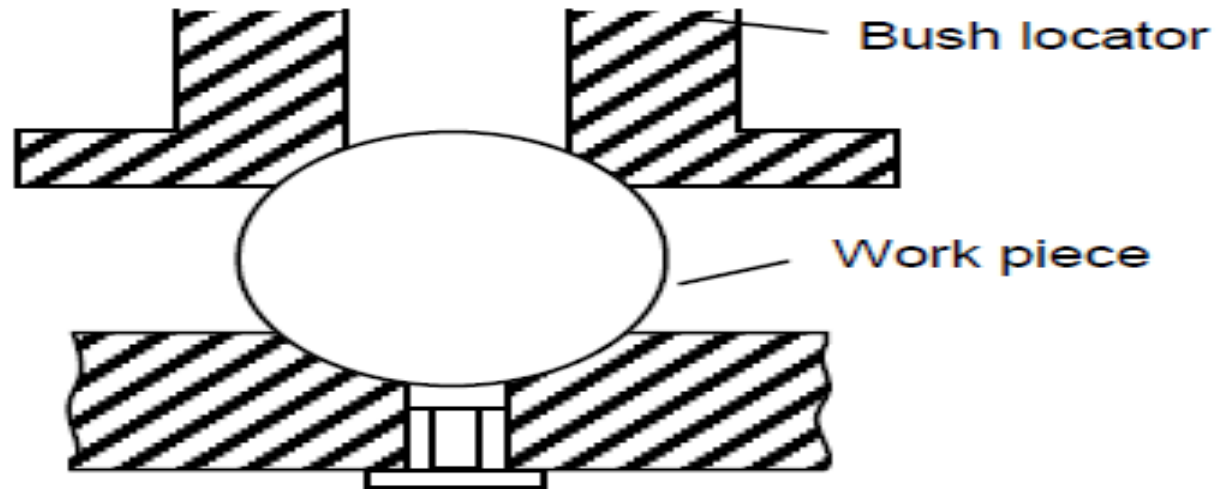
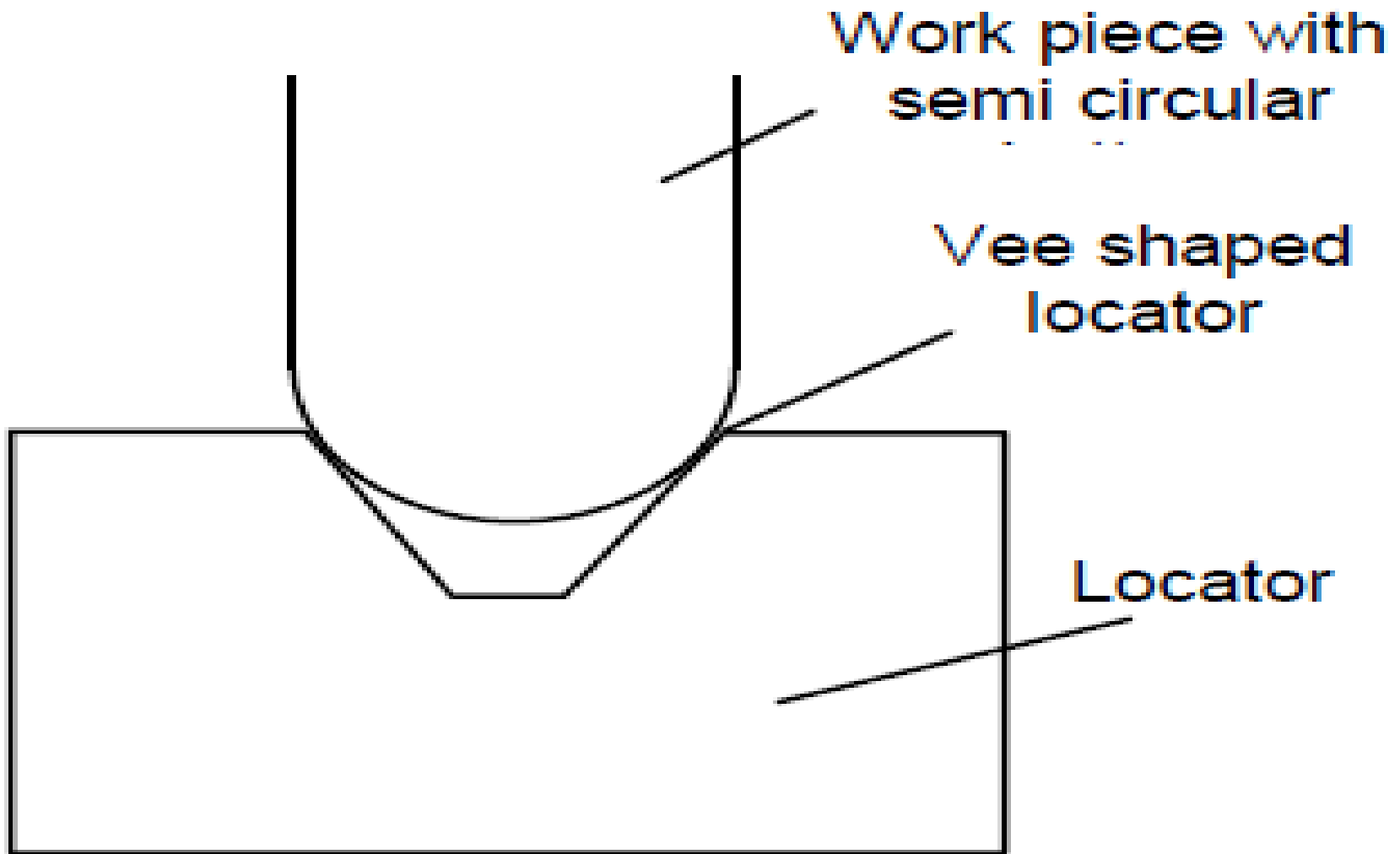

Figure 4.7 : Drill Bush Locator

Vee Locators

- ❑ This is quick and effective method of locating the workpiece with desired level of accuracy.
- ❑ This is used for locating the circular and semi-circular type of workpieces as shown in Figure .
- ❑ The main part of locating device is Vee shaped block which is normally fixed to the jig.
- ❑ This locator can be of two types fixed Vee locator and adjustable Vee locator.
- ❑ The fixed type locator is normally fixed on the jig and adjustable locator can be moved axially to provide proper grip of Vee band to the work piece.

Vee Locators



Figur 4.8 : Fixed V Locator

CLAMPING

To restrain the workpiece completely a clamping device is required in addition to locating device and jigs and fixtures

A clamping device holds the workpiece securely in a jig or fixture against the forces applied over it during on operation

Basic requirement of a good clamping device are listed below :

- ❑ It should rigidly hold the workpiece
- ❑ The workpiece being clamped should not be damaged due to application of clamping pressure by the clamping unit
- ❑ The clamping pressure should be enough to over come the operating pressure applied on the workpiece as both pressure act on the workpiece in opposite directions
- ❑ Clamping device should be capable to be unaffected by the vibrations generated during an operation

DIFFERENT TYPES OF CLAMPS

Common strap type clamping :

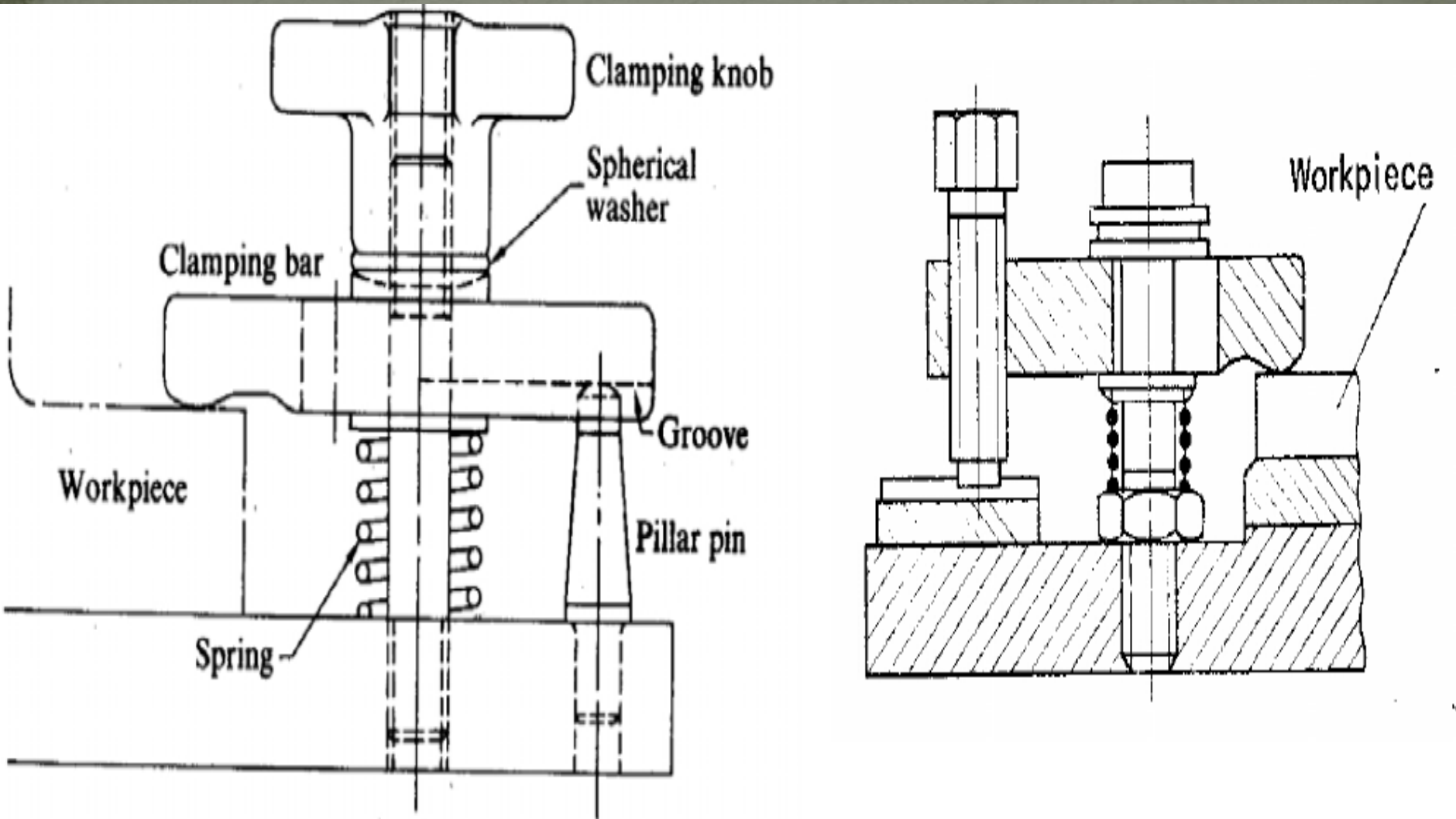

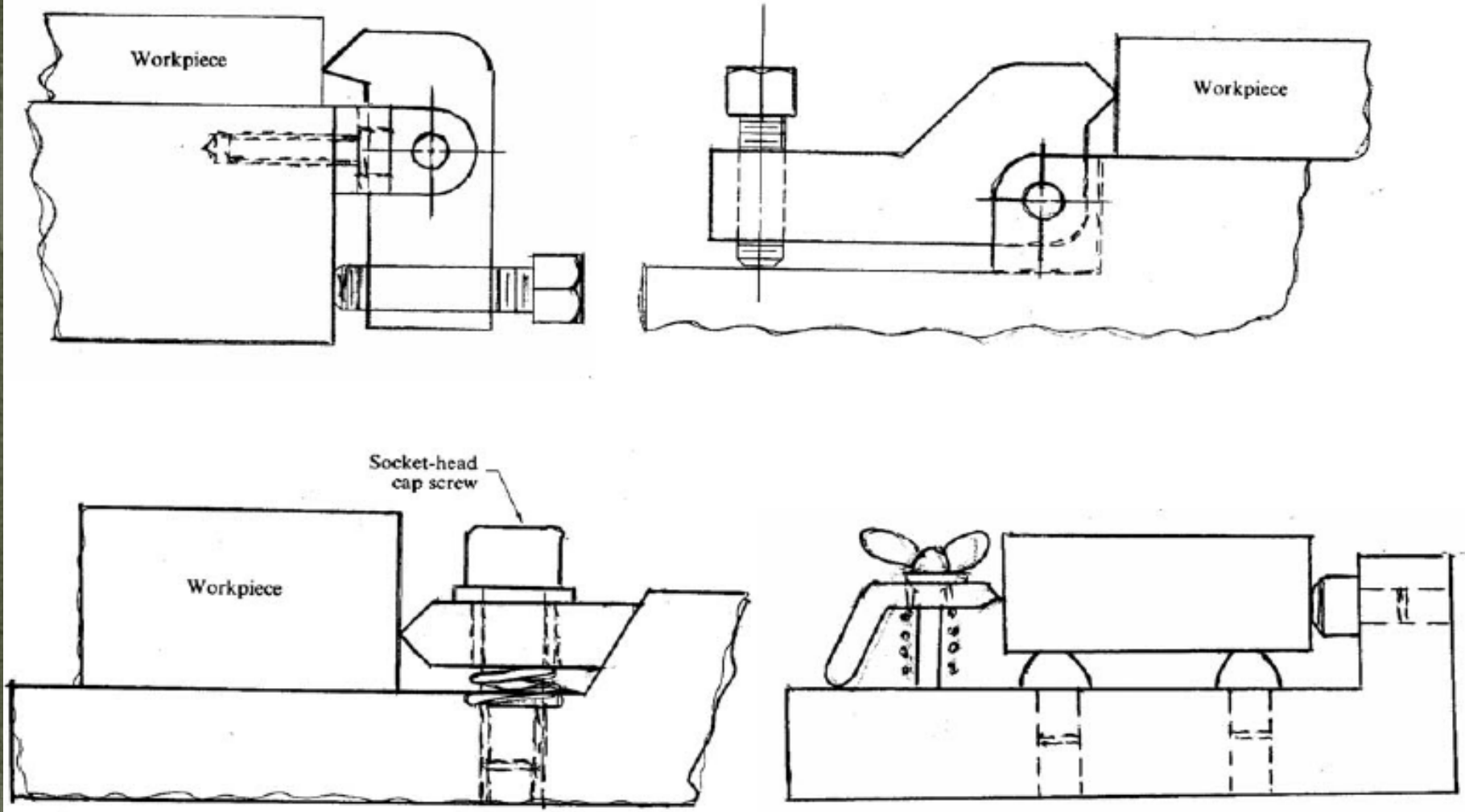
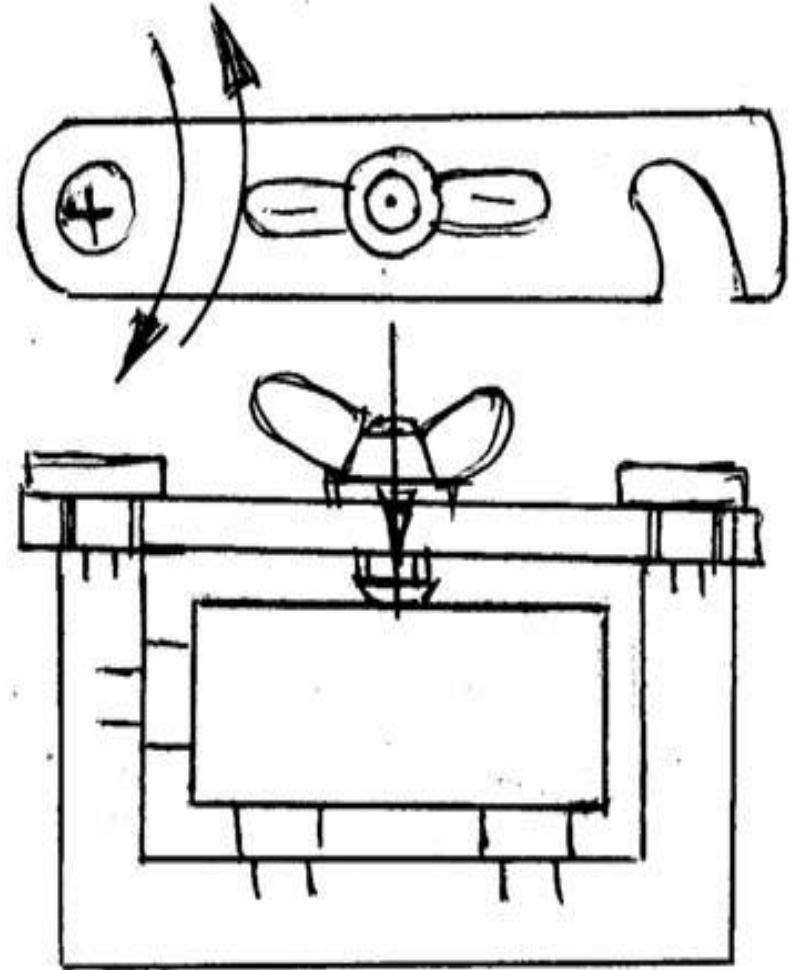
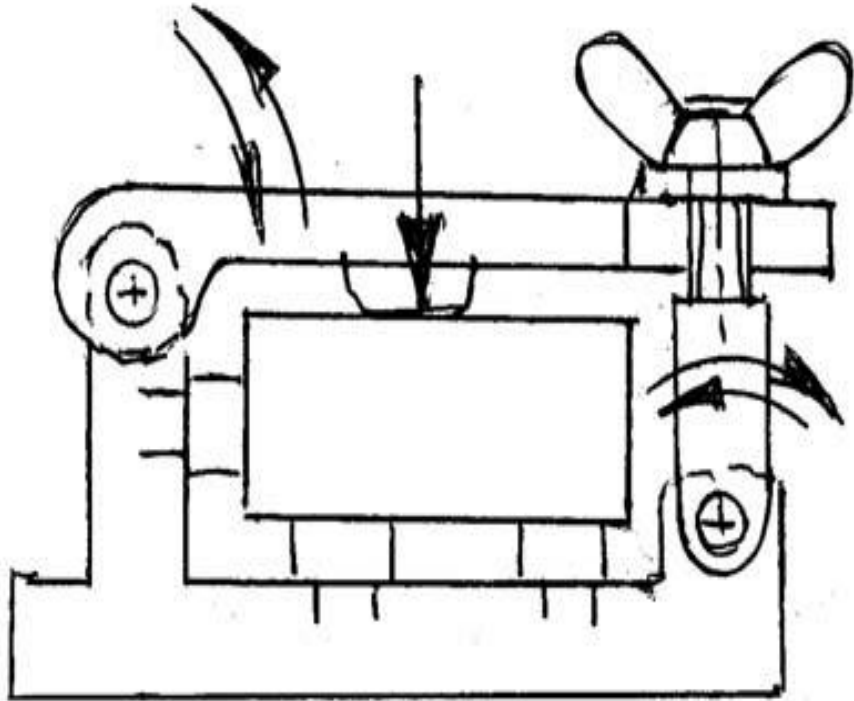

Fig. 8.1.18 Clamping from side for free machining of the top surface.

Clamping by swing plates



Quick clamping methods and systems

Use of quick acting nut :

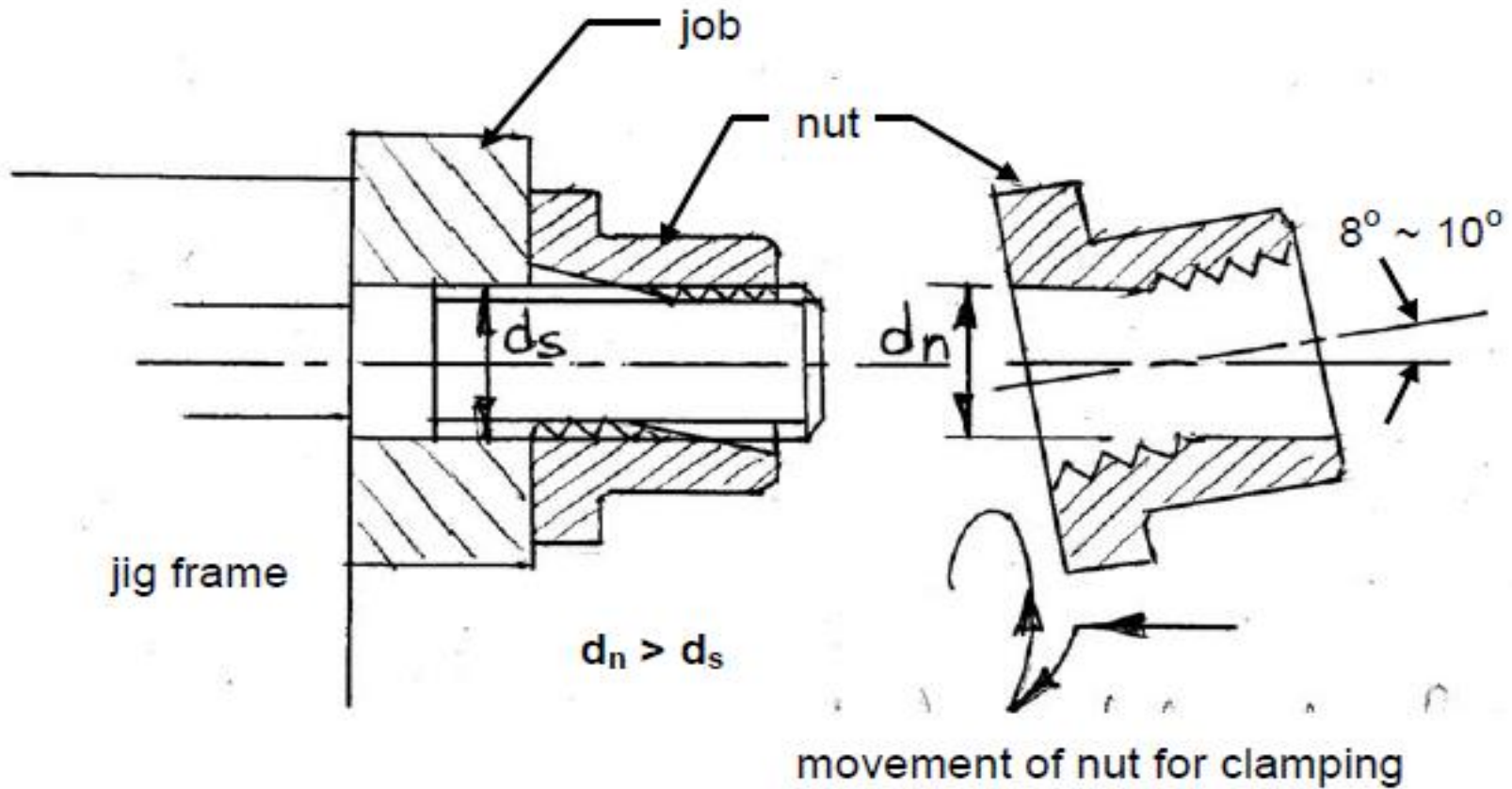
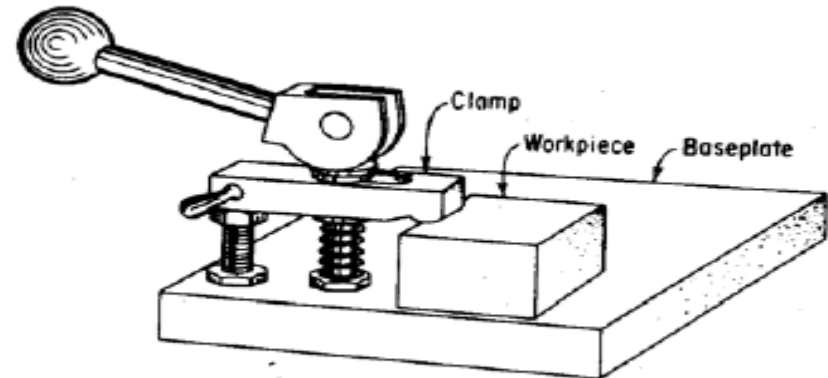
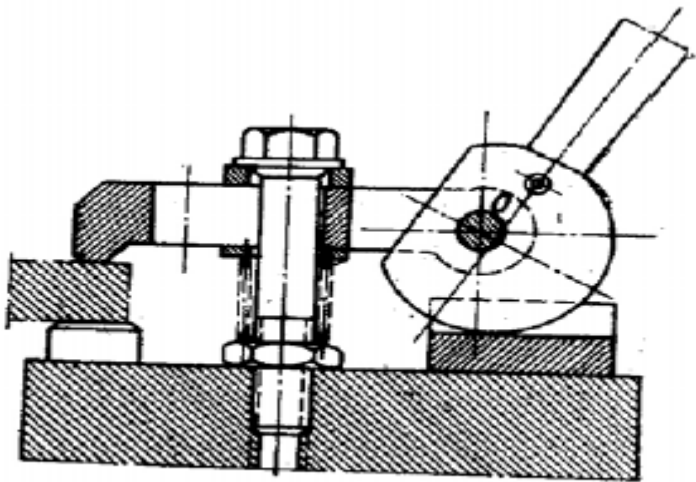
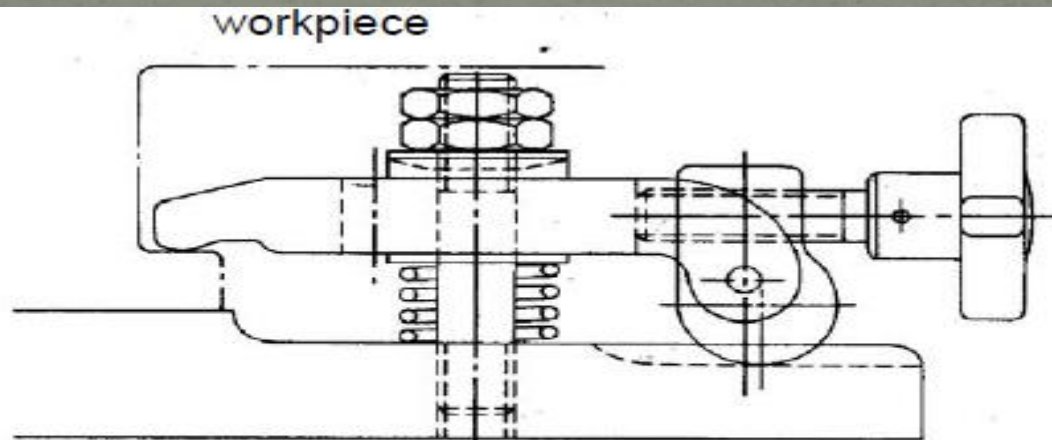

Fig. 8.1.20 Quick acting nut for rapid clamping.

Cam clamping



(a) clamping by cam



(b) screw and cam clamping from distance

Fig. 8.1.21 Quick clamping by cams.

JIGS

- ❑ Jigs are fabricated in different pieces and joined together by welding.
- ❑ Normally jigs are made of hardened steel, which are wear resistant, corrosion resistant, and thermally insensitive.
- ❑ Their dimensional accuracy directly influences the accuracy of performance of the operations where these are used.

DIFFERENT TYPES OF JIGS

Drilling Jigs

Drilling jigs are used for large number of operations. Different types of drilling jigs are described below

Template Jig :

- ❑ It is simply a plate made to the shape and size of the work piece; with the require number of holes made it.
- ❑ It is placed on the work piece and the hole will be made by the drill; which will be guided through the holes in the template plate should be hardened to avoid its frequent replacement
- ❑ This type of jig is suitable if only a few part are to be made.

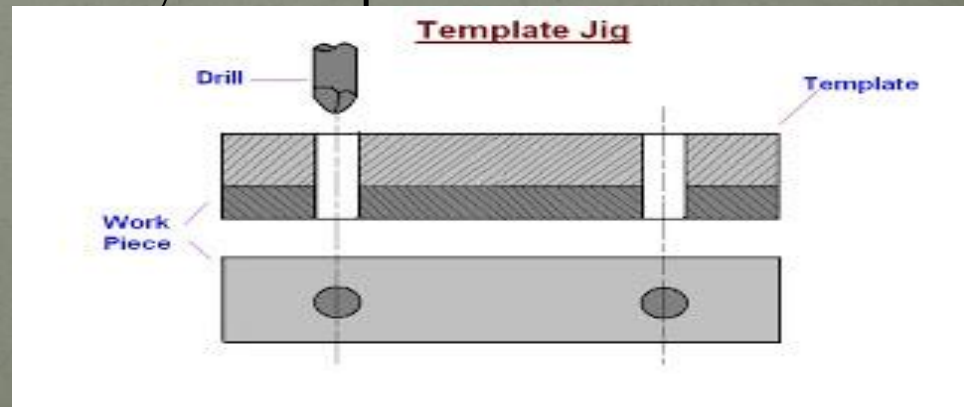
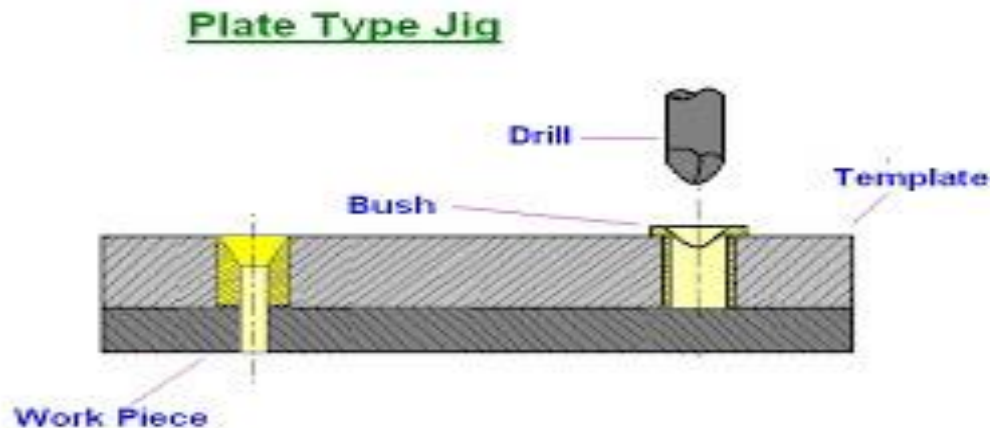

Plate Type Jig

- ❑ This is an improvement of the template type of jig
- ❑ In place of simple holes, drill bushes are provided in the plate to guide the drill
- ❑ The work piece can be clamped to the plate and holes can be drilled.
- ❑ The plate jig are employed to drill holes in large parts, maintaining accurate spacing with each other.



Open Type Jig

In this jig the top of the jig is open; the work piece is placed on the top.

Open Type Jig

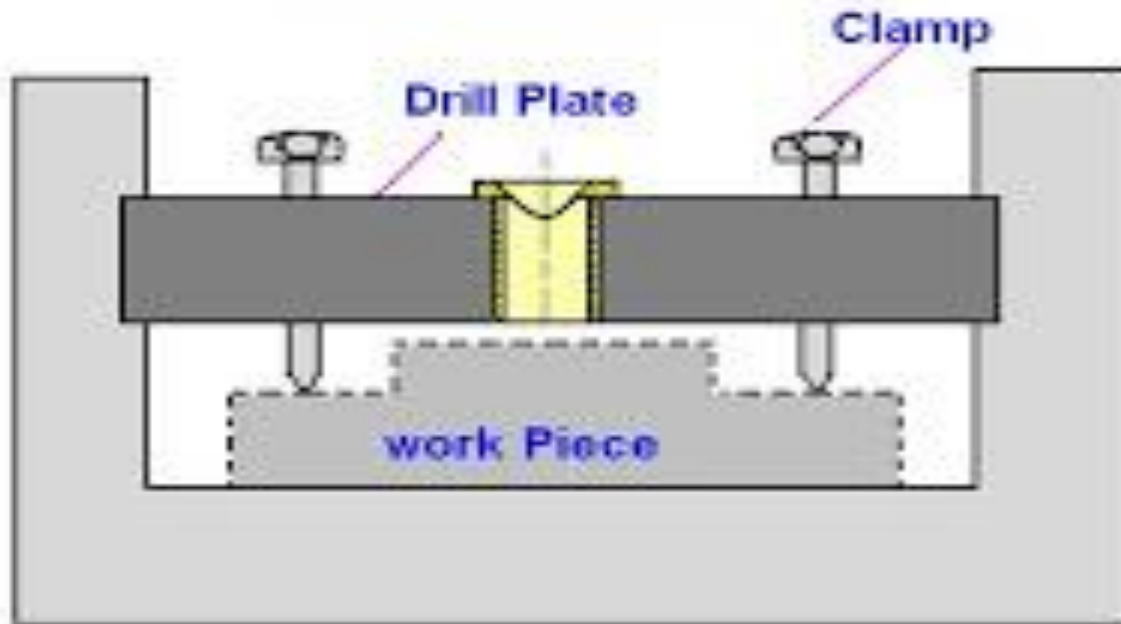

Box Type Jig

- ❑ When the holes are to drill more than one plane of the work piece , the jig has to be provided with equivalent number of bush plates.
- ❑ For positioning jig on the machine table feet have to be provided opposite each drilling bush plate
- ❑ One side of the jig will be provided with a swinging leaf for loading a

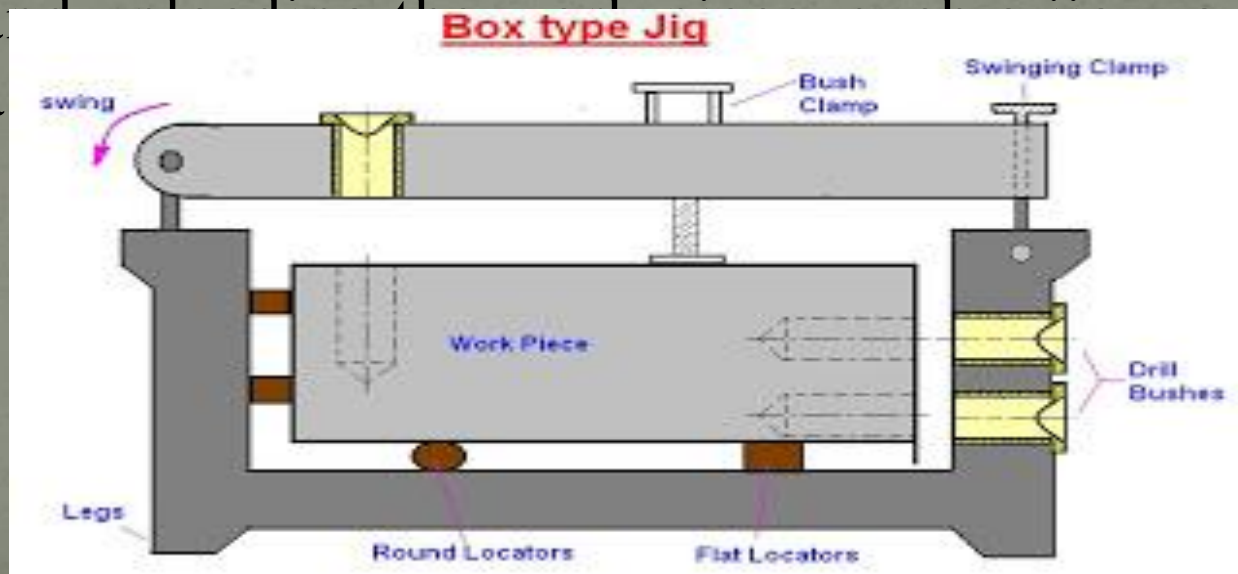

Channel jig

- ❑ The channel jig is a simple type of jig having channel like cross section
- ❑ The component is fitted within the channel is located and clamped by locating the knob.
- ❑ The tool is guided through the drill bush

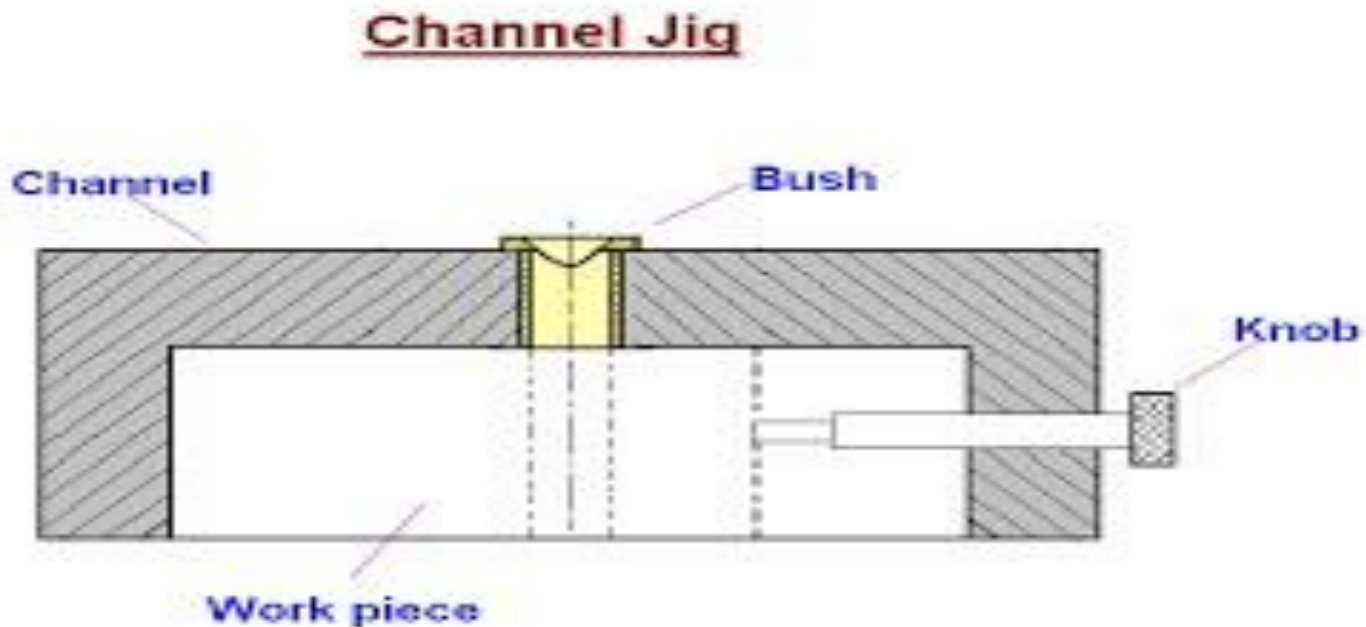

Leaf Jig

- ❑ It is also a sort of open type jig , in which the top plate is arrange to swing about a fulcrum point
- ❑ so that it is completely clears the jig for easy loading and unloading of the work piece
- ❑ The drill bushes are fitted into the plates , which is also known as leaf , latch or lid.

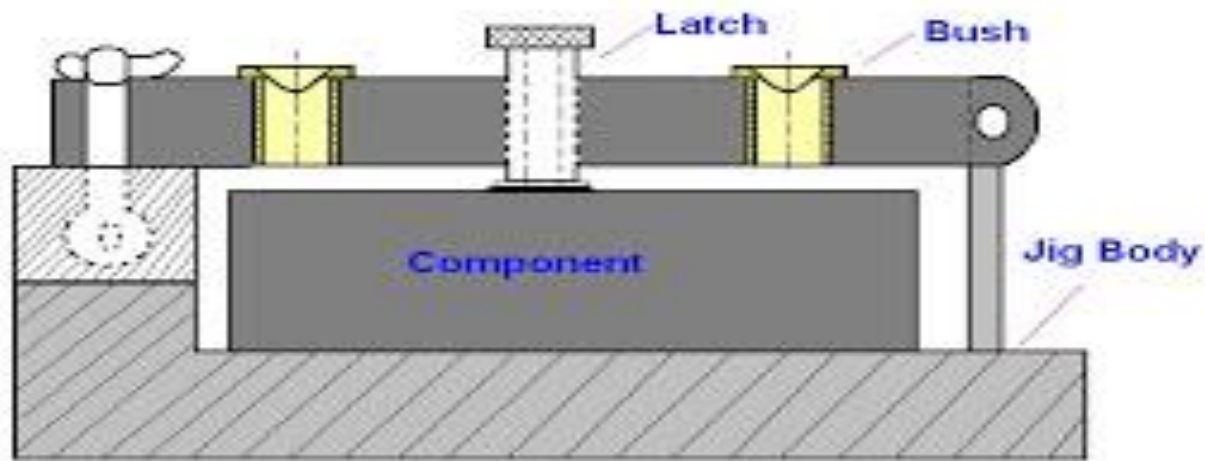

Leaf Jig

FIXTURES

Fixtures are designed specifically for an operation and so these are named on the base of the operation to be carried out with their help

Fixtures are used to hold the work piece properly to carryout the operations.

Different types of fixtures are listed below

- (a) Turning fixtures

- (b) Milling fixtures
- (c) Fixture for grinding
- (d) Fixture for broaching
- (e) Fixture for boring/drilling
- (f) Tapping fixture
- (g) Fixture for welding
- (h) Assembling fixture

Milling Fixtures

- ❑ Fixtures used to perform different types of milling operations are called milling fixtures
- ❑ A Milling fixture is a work holding device which is firmly clamped to the table of the milling machine
- ❑ It holds the work piece in correct position as the table movement carries it past the cutter or cutters

Milling Fixtures

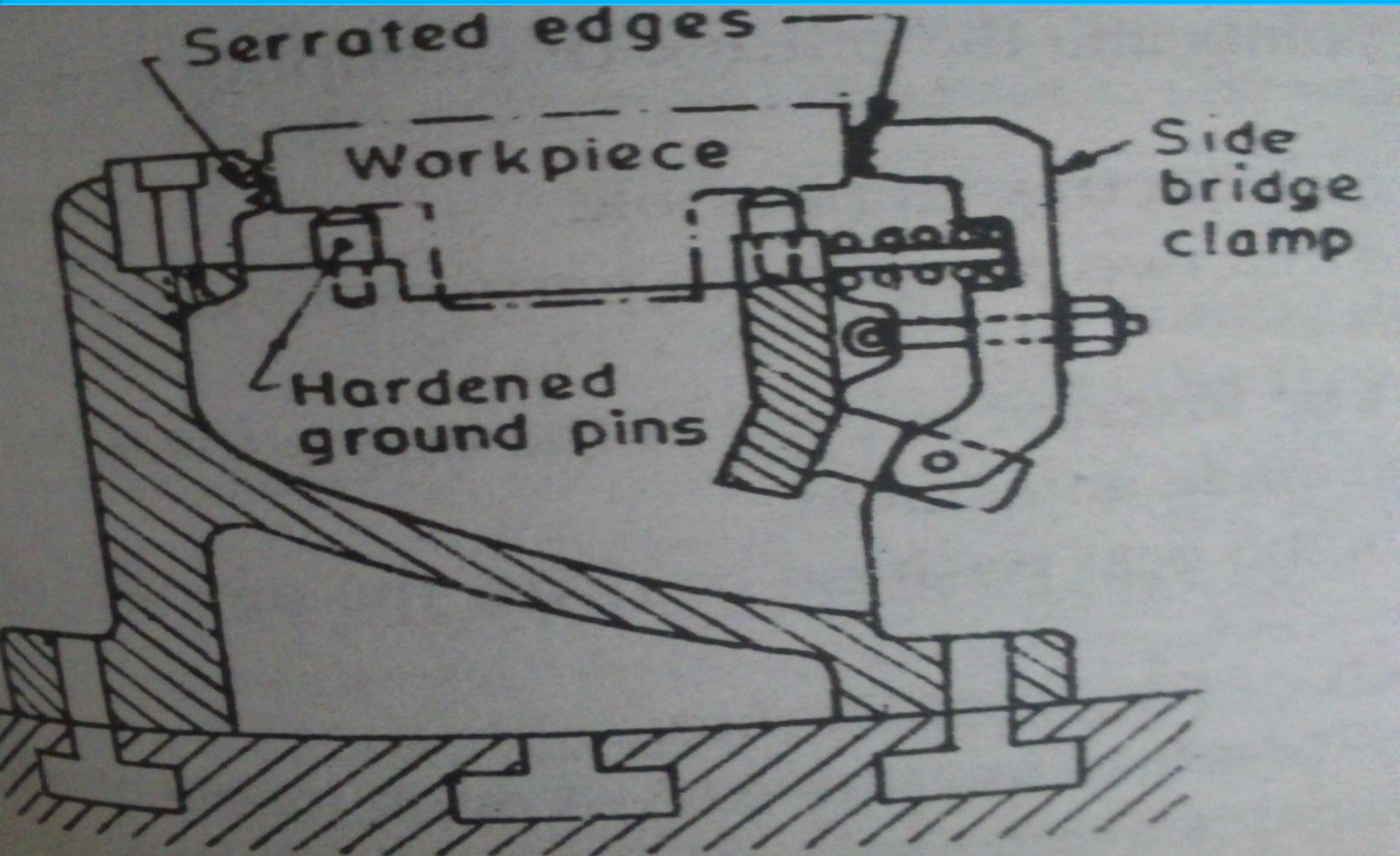

ECONOMICS OF JIGS

- ❑ Jigs is very important in manufacturing industry
 - ❑ smooth and easier to operations

(a) Productivity:

- ❑ Jigs eliminate individual marking
- ❑ Positioning and frequent checking.
- ❑ This reduces operation time and increases productivity.

(b) Inter changeability:

- ❑ Jigs facilitate uniform quality in manufacture.
- ❑ There is no need of frequent changes for selective assembly.
- ❑ Any part of the machine would fit properly in assembly.
 - ❑ similar components are interchangeable.

(c) Skill reduction:

- ❑ Jigs simplify locating and clamping of the work-pieces
- ❑ Tool guiding elements ensure correct positioning of the tools with respect to the work pieces.
- ❑ There is no need for skilful setting of the work-piece or tool
- ❑ Any average person can be trained to use jigs.
- ❑ The replacement of a skilled workman with unskilled labour can effect substantial saving in labour cost

(d) Cost reduction

- ❑ Higher production,
- ❑ reduction in scrap,
- ❑ easy assembly and
- ❑ savings in labour costs

result in substantial reduction in the cost of work-pieces produced with
jigs