

# Non-linear application in op-amp

- When opamp operated in open-loop configurations, the slightest change in input voltage will force the op-amp into saturation ( $V_{POS}$  or  $V_{NEG}$ )
- Op-amps are sometimes used in non-linear applications as square wave generator.
- By comparing these two input voltages: positive input voltages,  $V^+$  and negative input voltage,  $V^-$  where:
$$V_O = V_{CC} \text{ if } V^+ > V^-$$
$$V_O = -V_{CC} \text{ if } V^+ < V^-$$
$$V_O = A(V^+ - V^-) \text{ if } V^- < V_O < V^+$$
- Input current,  $I_i = 0$

# Comparator

An analog comparator has two inputs one is usually a constant reference voltage  $V_R$  and other is a time varying signal  $v_i$  and one output  $v_o$ . The basic circuit of a comparator is shown in **Fig. 1**

When the noninverting voltage is larger than the inverting voltage the comparator produces a high output voltage ( $+V_{sat}$ ). When the non-inverting output is less than the inverting input the output is low ( $-V_{sat}$ ). **Fig. 2** also shows the output of a comparator for a sinusoidal.

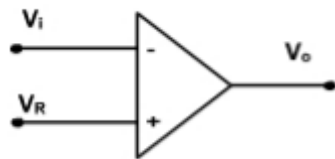

Fig. 1

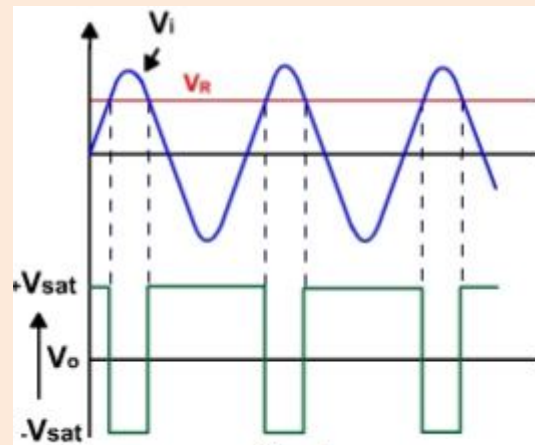
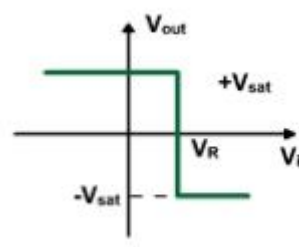

Fig. 2

$$V_o = -V_{sat} \text{ if } v_i > V_R$$

$$= +V_{sat} \text{ if } v_i < V_R$$

If  $V_R = 0$ , then slightest input voltage (in mV) is enough to saturate the OPAMP and the circuit acts as zero crossing detector shown in fig .3

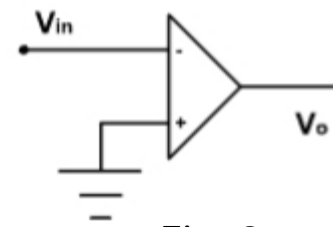
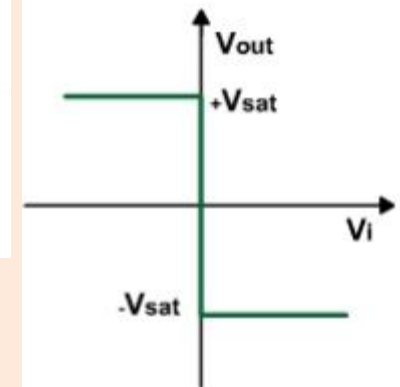

Fig. 3



# Regenerative Comparator (Schmitt Trigger)

If the input to a comparator contains noise, the output may be erratic when  $v_{in}$  is near a trip point. For instance, with a zero crossing, the output is low when  $v_{in}$  is positive and high when  $v_{in}$  is negative. If the input contains a noise voltage with a peak of 1mV or more, then the comparator will detect the zero crossing produced by the noise. [Fig. 1](#), shows the output of zero crossing detection if the input contains noise.

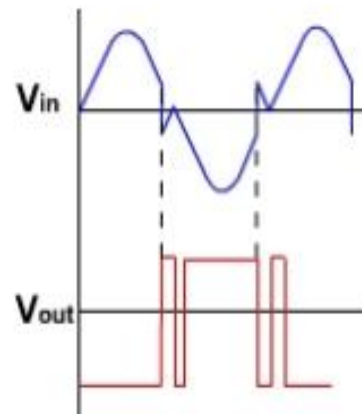

Fig. 1

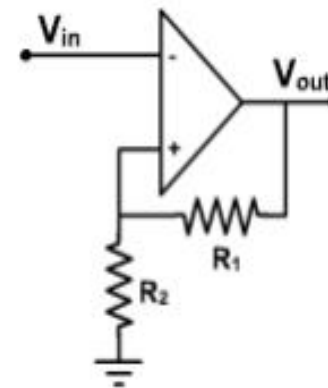

Figure 2

This can be avoided by using a Schmitt trigger, circuit which is basically a comparator with positive feedback. [Fig. 2](#), shows an inverting Schmitt trigger circuit using OPAMP.

Because of the voltage divider circuit, there is a positive feedback voltage. When OPAMP is positively saturated, a positive voltage is feedback to the non-inverting input, this positive voltage holds the output in high state. ( $v_{in} < v_f$ ). When the output voltage is negatively saturated, a negative voltage feedback to the inverting input, holding the output in low state.

When the output is  $+V_{sat}$  then reference voltage  $V_{ref}$  is given by

$$V_{ref} = \frac{R_2}{(R_1 + R_2)} * V_{sat} = (+\beta V_{sat})$$

If  $V_{in}$  is less than  $V_{ref}$  output will remain  $+V_{sat}$ .

When input  $v_{in}$  exceeds  $V_{ref} = +V_{sat}$  the output switches from  $+V_{sat}$  to  $-V_{sat}$ . Then the reference voltage is given by

$$V_{ref} = \frac{-R_2}{(R_1 + R_2)} * V_{sat} = (-\beta V_{sat})$$

The output will remain  $-V_{sat}$  as long as  $v_{in} > V_{ref}$ .

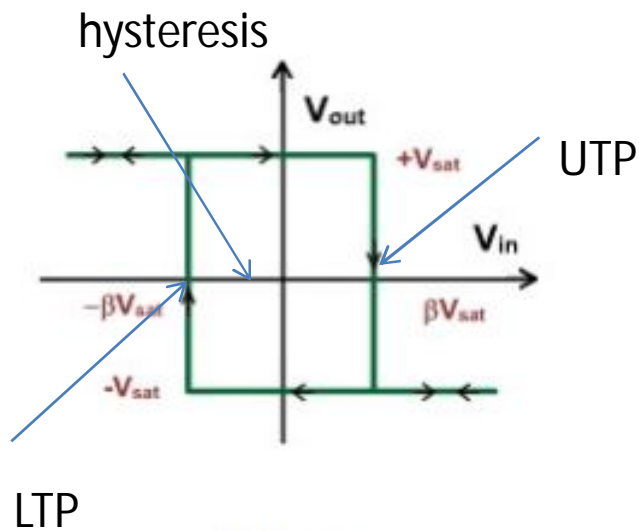

Fig. 3

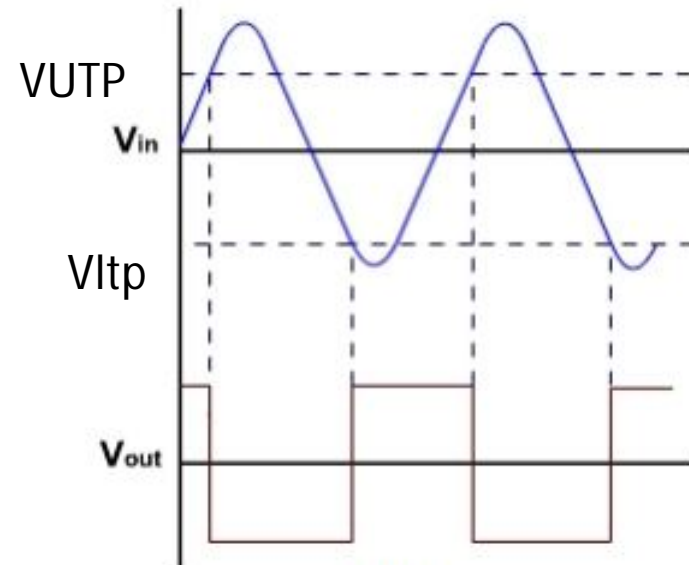

Fig. 4

If  $v_{in} < V_{ref}$  i.e.  $v_{in}$  becomes more negative than  $-V_{sat}$  then again output switches to  $+V_{sat}$  and so on. The transfer characteristic of Schmitt trigger circuit is shown in [fig. 3](#). The output is also shown in [fig. 4](#) for a sinusoidal wave. If the input is different than sine even then the output will be determined in a same way.

Positive feedback has an unusual effect on the circuit. It forces the reference voltage to have the same polarity as the output voltage, The reference. voltage is positive when the output voltage is high ( $+v_{sat}$ ) and negative when the output is low ( $-v_{sat}$ ).

In a Schmitt trigger, the voltages at which the output switches from  $+v_{sat}$  to  $-v_{sat}$  or vice versa are called upper trigger point (UTP) and lower trigger point (LTP). the difference between the two trip points is called hysteresis.

$$UTP = \frac{R_2}{R_1 + R_2} V_{sat}$$

$$LTP = \frac{R_2}{R_1 + R_2} (-V_{sat})$$

$$V_{hys} = UTP - LTP$$

$$= \frac{R_2}{R_1 + R_2} V_{sat} - \frac{R_2}{R_1 + R_2} (-V_{sat})$$

$$= 2 \left( \frac{R_2}{R_1 + R_2} \right) V_{sat}$$

$$= 2\beta V_{sat}$$

# Logarithmic Amplifier

Figure shows an elementary logarithmic amplifier, i.e. the output is proportional to the logarithm of the input. A BJT as feedback provides a larger input dynamic range.

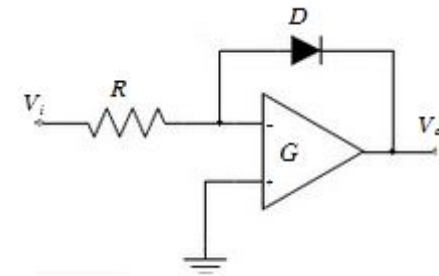

Because the Op-Amp is mounted as an inverting amplifier, if  $v_i$  is positive, then  $v_o$  must be negative and the diode is in conduction.

We must have

$$i \simeq I_s e^{-qV_o/k_B T} \quad I_s \ll 1,$$

where  $q < 0$  is the electron charge. Considering that

$$i = \frac{v_i}{R},$$

and after some algebra we finally get

$$v_o = \frac{k_B T}{-q} [\ln(v_i) - \ln(RI_s)].$$

The constant term  $\ln(RI_s)$  is a systematic error that can be estimated and subtracted at the output. It is worth to notice that  $v_i$  must be positive to have the circuit working.

# Anti-Logarithmic Amplifier

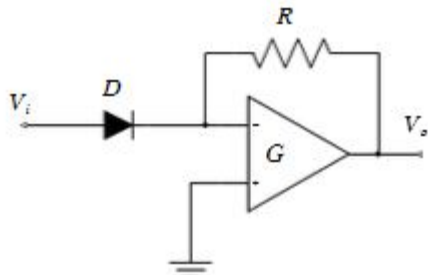

Figure shows an elementary logarithmic amplifier, i.e. the output is proportional to the inverse of logarithm of the input. Same remarks of the logarithmic amplifier about the npn BJT applies to this circuit.

The current flowing through the diode or the BJT is

$$i \simeq I_s e^{-qV_i/k_B T} \quad I_s \ll 1,$$

where in the argument of the exponential function we have the input voltage. Considering that

$$v_o = -Ri,$$

thus

$$v_o \simeq -RI_s e^{-qV_i/k_B T}.$$

If the input  $v_i$  is negative, we have to reverse the diode's connection or replace the BJT with a pnp BJT.



# Logarithmic Multiplier

Analog multiplier based on a two log one antilog and one adder circuits.

