

# Feedback Amplifier

- General Feedback structure
- Negative Feedback
- Feedback Topology
- Analysis of feedback applications
  - Close-Loop Gain
  - Input/Output resistances

# General Feedback Structure

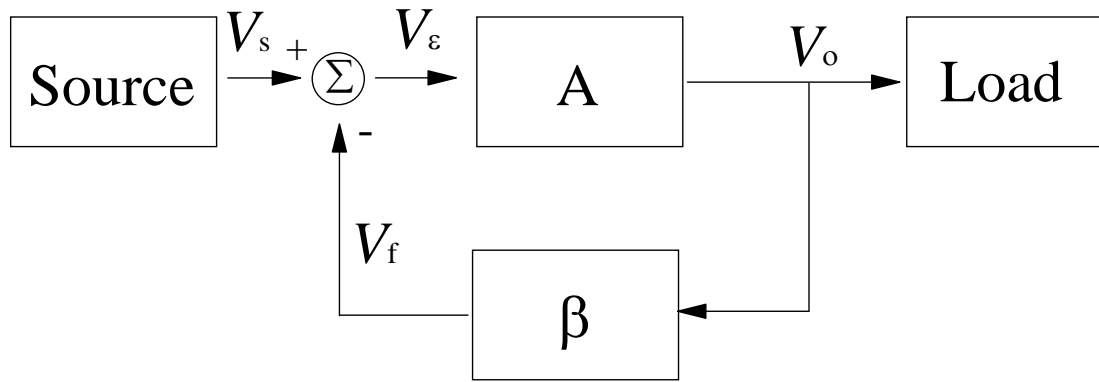

$A$  : Open Loop Gain  
 $A = V_o / V_\epsilon$

$\beta$  : feedback factor  
 $\beta = V_f / V_o$

$$V_\epsilon = V_s - V_f$$

$$V_f = \beta \cdot V_o$$

$$V_\epsilon = V_s - \beta \cdot V_o$$

$$V_o = A \cdot V_\epsilon$$

Close loop gain :  $A_{CL} = \frac{V_o}{V_s} = \frac{A}{1 + A\beta} = \frac{1}{\beta} \left( \frac{T}{1 + T} \right)$

Loop Gain :  $T = A \cdot \beta$

Amount of feedback :  $1 + A \cdot \beta$

Note :  $A_{CL} \Big|_{A \rightarrow \infty} = \frac{1}{\beta}$

# Negative Feedback Properties

- Negative feedback takes a sample of the output signal and applies it to the input to get several desirable properties. In amplifiers, negative feedback can be applied to get the following properties
  - Desensitized gain : gain less sensitive to circuit component variations
  - Reduce nonlinear distortion : output proportional to input (constant gain independent of signal level)
  - Reduce effect of noise
  - Control input and output impedances by applying appropriate feedback topologies
  - Extend bandwidth of amplifier
- All of these properties can be achieved by trading off gain

# Gain De-sensitivity

- Feedback can be used to desensitize the closed-loop gain to variations in the basic amplifier.
- Assume  $\beta$  is constant. Take differentials of the closed loop gain equation gives,

$$A_{CL} = \frac{A}{1 + A\beta} \quad \xrightarrow{\text{Differential respected with } A} \quad \frac{dA_{CL}}{dA} = \frac{1}{(1 + A\beta)^2} \text{ or } dA_{CL} = \frac{dA}{(1 + A\beta)^2}$$

- Divided by  $A_{CL}$ , the close loop gain sensitivity is equal to,

$$\frac{dA_{CL}}{A_{CL}} = \frac{dA}{(1 + A\beta)^2} \frac{(1 + A\beta)}{A} = \frac{1}{1 + A\beta} \frac{dA}{A}$$

- This result shows the effects of variations in  $A$  on  $A_{CL}$  is mitigated by the feedback amount.
- $(1 + A\beta)$  is also called the desensitivity amount.

# Types of feed back

- **Negative feedback:** If the signal fed back is of opposite polarity or out of phase by  $180^\circ$  (or odd integer multiple of  $180^\circ$ ) with respect to input signal, feedback is called negative feedback.
- -ve feedback is also known as **degenerative feedback** because when used it degenerates (reduces) the output voltage amplitude and in turn reduces the voltage gain.  
**Uses:**
  - When used in amplifier, -ve feedback stabilizes the gain, increases the bandwidth and changes the input and output resistances, reduced voltage gain, decrease in non linear distortion and reduces the effect of variations in temperature and supply voltages on the output of op-amp.
- **Positive feedback:** If the signal fed back is of the same polarity or in phase with the input signal, the feedback is called positive feedback.
- In + ve feedback the feedback signal aids the input signal, so referred as **regenerative feedback**. +ve feedback is used in oscillator circuits.

- A op amp that uses feedback is called feedback amplifier.
- Feedback forms a close loop between input and output so referred as closed loop amplifier also.
- Feedback amplifier consists of two parts: op-amp and feedback circuit (made up of either passive, active or combination of both components)
- There are four ways to connect these 2 blocks according to whether the voltage or current is fed back to the input in series or in parallel:-

**Voltage series feedback** } The voltage across RL is input voltage to feedback circuit.

**Voltage shunt feedback** } Feedback quantity is the output of feedback circuit and is proportional to output voltage.

**Current series feedback** } Load current flows into feedback circuit . Output of feedback circuit

**Current shunt feedback** } (either current or voltage) is proportional to load current.

# Basic Feedback Topologies

Depending on the input signal (voltage or current) to be amplified and form of the output (voltage or current), amplifiers can be classified into four categories. Depending on the amplifier category, one of four types of feedback structures should be used.

## **(Type of Feedback)**

- (1) Series (Voltage)
- (2) Series (Voltage)
- (3) Shunt (Current)
- (4) Shunt (Current)

## **(Type of Sensing)**

- Shunt (Voltage)
- Series (Current)
- Shunt (Voltage)
- Series (Current)

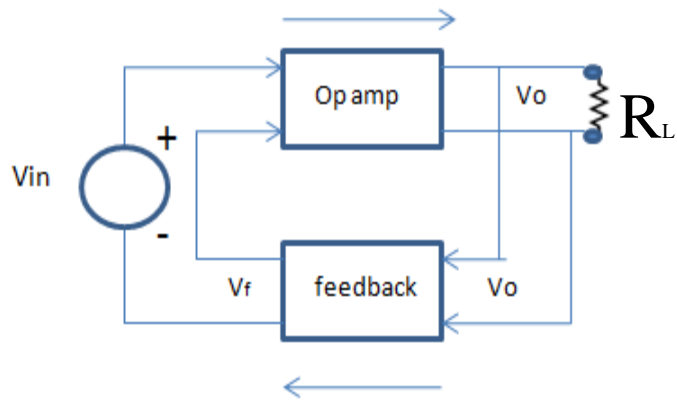

Fig. A voltage-series

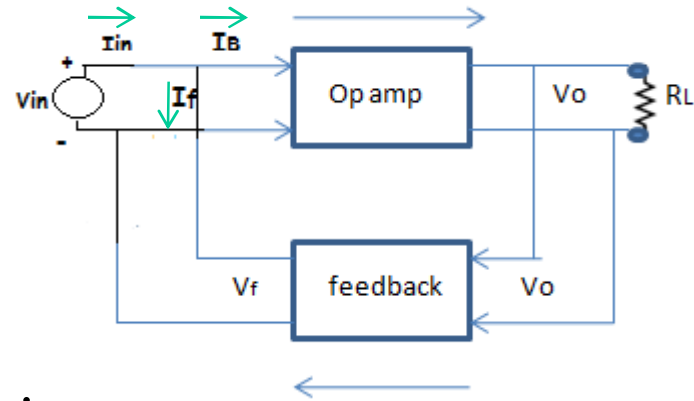

Fig. B voltage-shunt

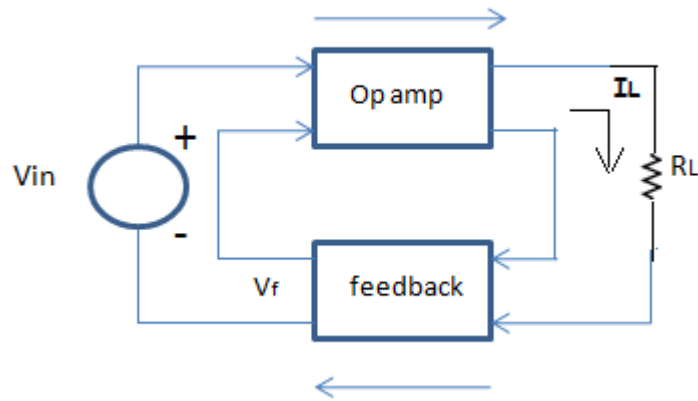

Fig. C current-series

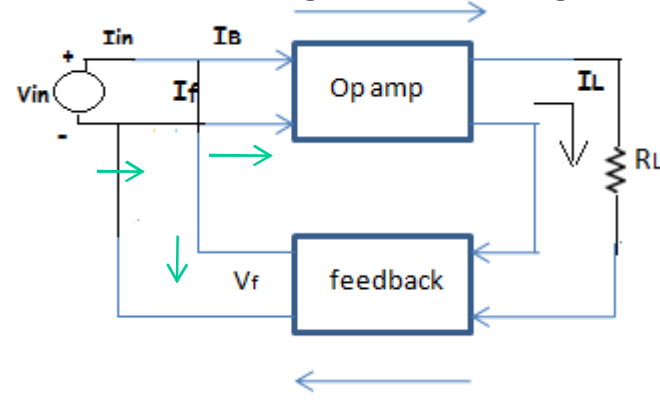
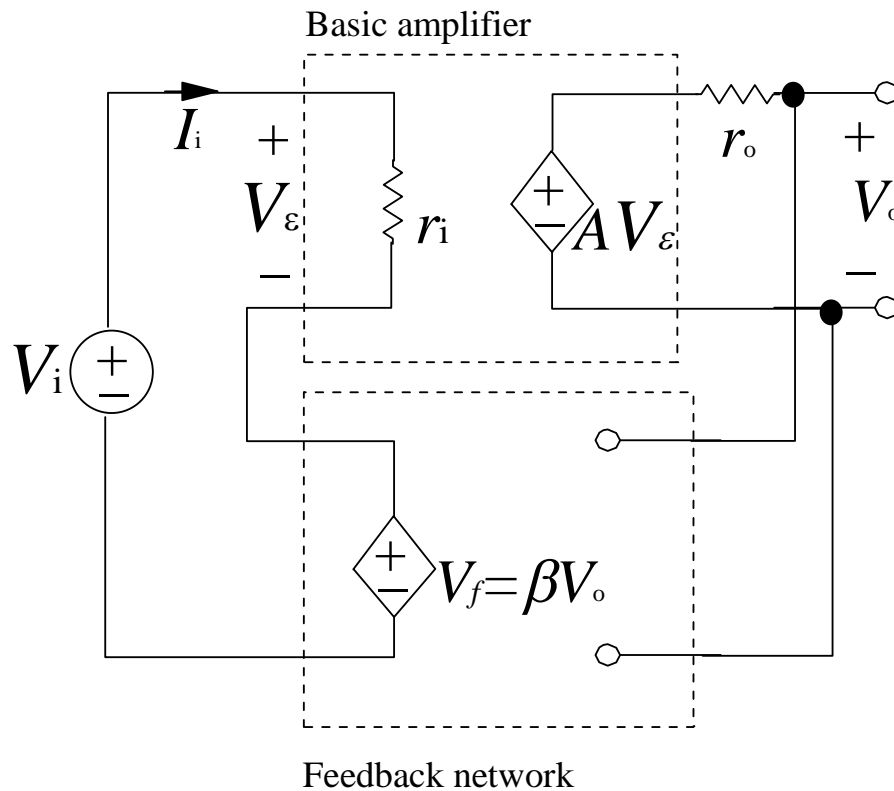

Fig. D current-shunt



# Feedback Structure (Series-Shunt) OR VOLTAGE SERIES



- Voltage amplifier voltage-controlled voltage source
- Requires high input impedance, low output impedance
- Voltage-voltage feedback

Voltage Gain Calculation:

$$V_o = A \cdot V_\varepsilon$$

$$V_f = \beta \cdot V_o$$

$$V_i = V_\varepsilon + V_f = \frac{V_o}{A} + \beta \cdot V_o$$

(Close Loop Voltage Gain)

$$\Rightarrow A_{CL} = \frac{V_o}{V_i} = \frac{1}{\beta} \left( \frac{T}{1+T} \right)$$

where  $T = A\beta$

And, we get

$$V_o = \frac{V_i \cdot A}{1 + A \cdot \beta}$$

$$V_i = V_\varepsilon (1 + A \cdot \beta)$$

# Input/Output Resistance (Series-Shunt)

Input Resistance:

$$R_{in} = \frac{V_i}{I_i}$$

$$V_i = (1+T) \cdot V_\varepsilon$$

$$I_i = \frac{V_\varepsilon}{r_i} = \frac{V_i}{(1+T) \cdot r_i}$$

$$R_{in} = \frac{V_i}{I_i} = (1+T) \cdot r_i$$

Output Resistance

(Closed loop output resistance with zero input voltage)

$$R_{out} |_{V_i=0} = \frac{V_o}{I_o}$$

$$I_o = \frac{V_o - A \cdot V_\varepsilon}{r_o}$$

$$V_\varepsilon + \beta \cdot V_o = V_i = 0$$

$$V_\varepsilon = -\beta \cdot V_o$$

$$I_o = \frac{V_o + A \cdot \beta \cdot V_o}{r_o}$$

$$\Rightarrow R_{out} = \frac{V_o}{I_o} = \frac{r_o}{1 + A \cdot \beta} = \frac{r_o}{1 + T}$$

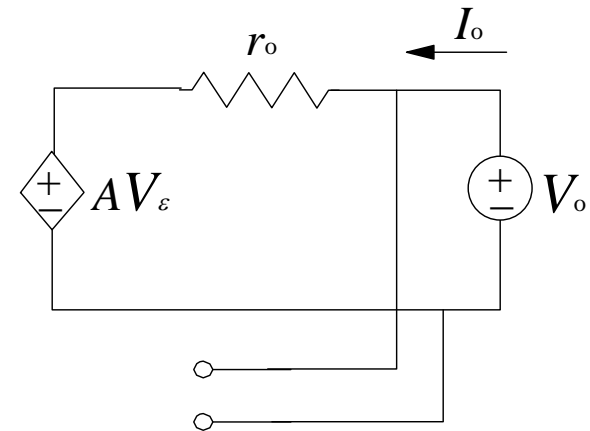

# Series-Shunt Example

Given:  $A = 10^5$ ,  $R_1 = 1k\Omega$ ,  $R_2 = 9k\Omega$ ,  $r_\pi = 10M\Omega$  and  $r_o = 40\Omega$

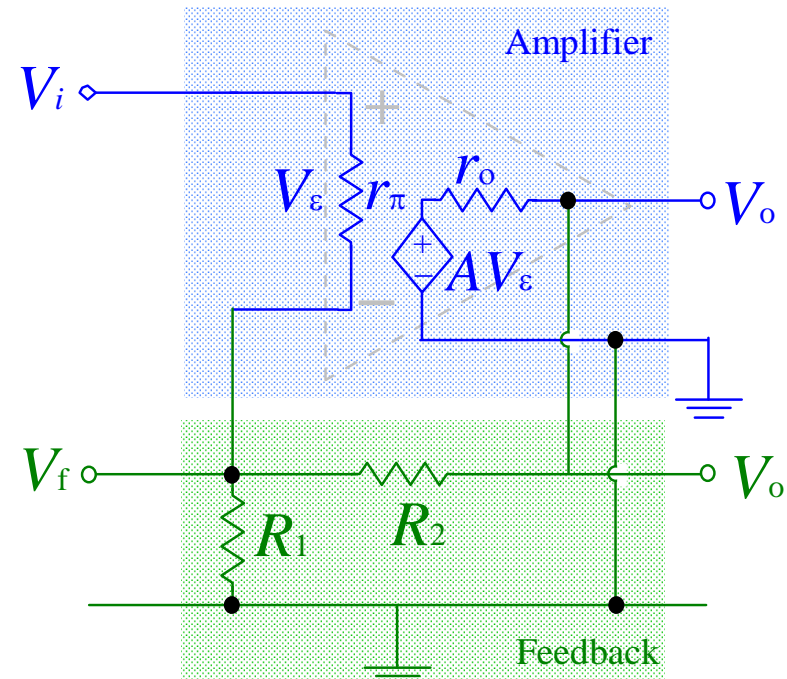
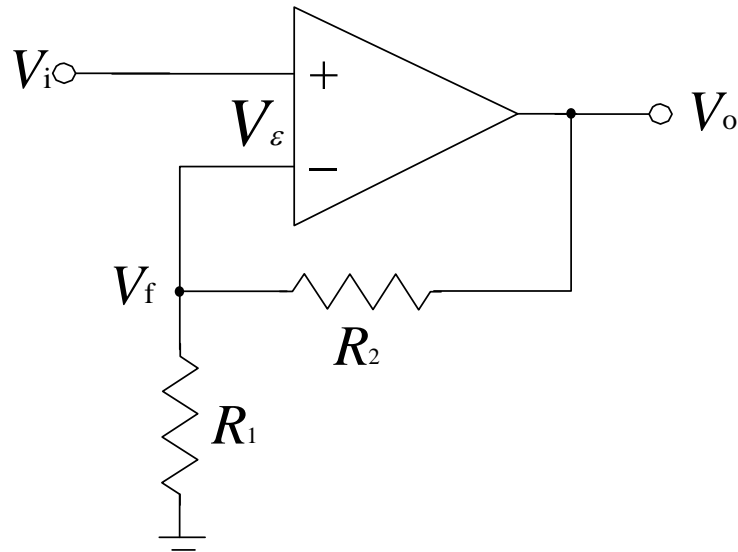

Equivalent circuit

It is observed that:

- (1) Series connection in input ports
  - (2) Shunt connection in output ports
- $\Rightarrow$  Series-Shunt connection  
 $h$ -parameter should be used.

# Feedback Structure (Series-Series)

## OR current series

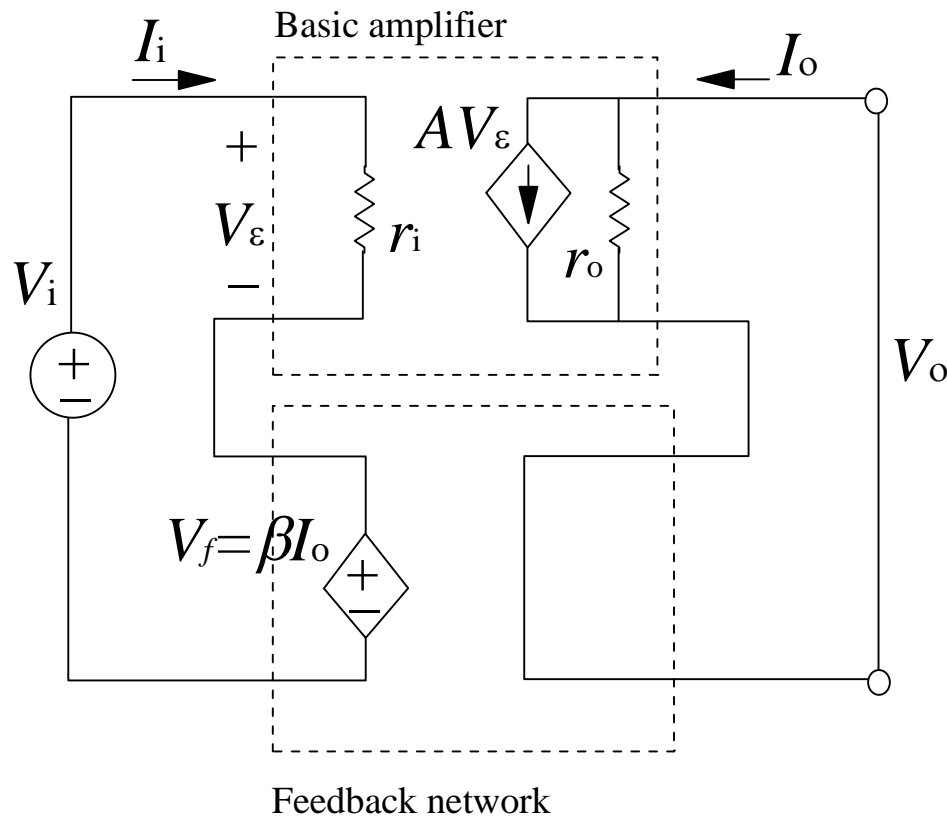

Gain Calculation :

$$I_o = A \cdot V_\epsilon$$

$$V_f = \beta \cdot I_o$$

$$V_i = V_\epsilon + V_f = \frac{I_o}{A} + \beta \cdot I_o$$

(Close Loop Transadmittance Gain)

$$\Rightarrow A_{CL} = \frac{I_o}{V_i} = \frac{1}{\beta} \left( \frac{T}{1+T} \right)$$

where  $T = A\beta$

And, we get

$$I_o = \frac{V_i \cdot A}{1 + A \cdot \beta}$$

$$V_i = V_\epsilon (1 + A \cdot \beta)$$

# Input/Output Resistance (Series-Series)

Input Resistance:

$$\begin{aligned}R_{\text{in}} &= \frac{V_i}{I_i} \\ &= \frac{(1+T) \cdot V_\varepsilon}{I_i} \\ &= (1+T) \cdot r_i\end{aligned}$$

Output Resistance

(Closed loop output resistance with zero input voltage)

$$R_{\text{out}} \big|_{V_i=0} = \frac{V_o}{I_o}$$

from input port,

$$V_\varepsilon = V_f = -\beta \cdot I_o$$

from output port,

$$I_o = AV_\varepsilon + \frac{V_o}{r_o} = -T \cdot I_o + \frac{V_o}{r_o}$$

$$\Rightarrow R_{\text{out}} = \frac{V_o}{I_o} = (1+T)r_o$$

# Feedback Structure (Shunt-Shunt) or voltage shunt

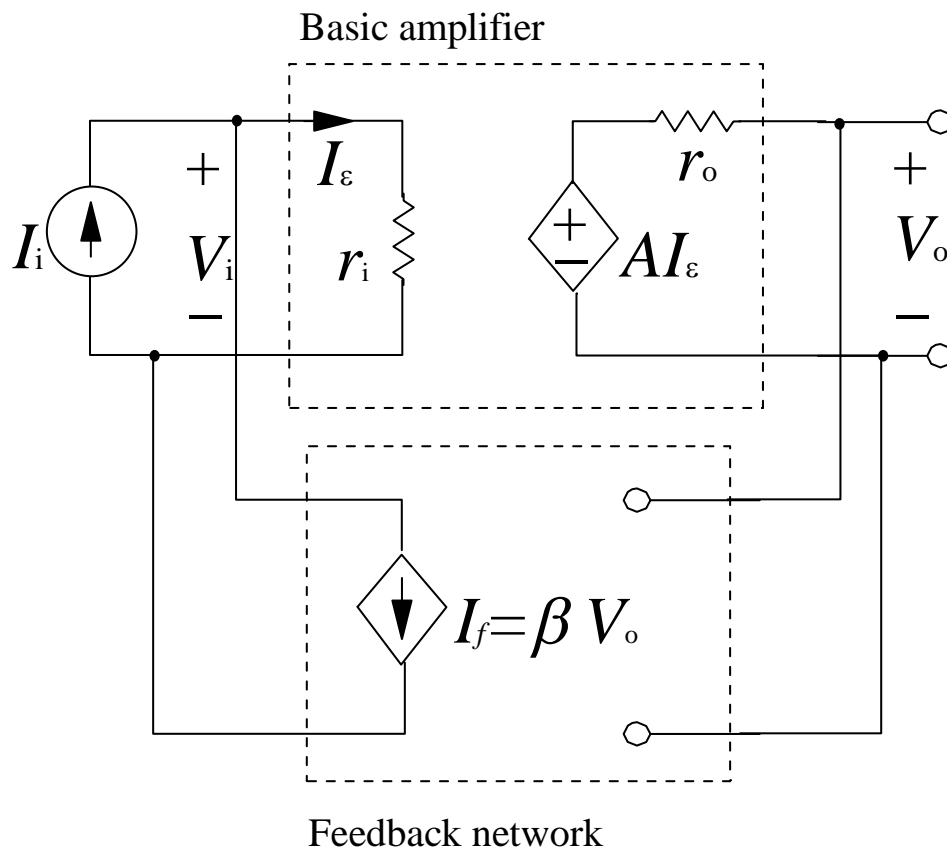

Gain Calculation :

$$V_o = A \cdot I_\epsilon = A(I_i - I_f)$$

$$I_f = \beta \cdot V_o$$

$$A(I_i - \beta V_o) = V_o$$

$$AI_i = (1 + T)V_o$$

(Close Loop Transimpedance Gain)

$$\Rightarrow A_{CL} = \frac{V_o}{I_i} = \frac{1}{\beta} \left( \frac{T}{1+T} \right)$$

where  $T = A\beta$

And, we get

$$V_o = \frac{I_i \cdot A}{1 + A \cdot \beta}$$

$$I_i = I_\epsilon (1 + A \cdot \beta)$$

# Input/Output Resistance (Shunt-Shunt)

Input Resistance:

$$\begin{aligned} R_{\text{in}} &= \frac{V_i}{I_i} \\ &= \frac{I_\varepsilon \cdot r_i}{I_\varepsilon (1+T)} \\ &= \frac{r_i}{(1+T)} \end{aligned}$$

Output Resistance

(Closed loop output resistance with zero input voltage)

$$R_{\text{out}} \big|_{V_i=0} = \frac{V_o}{I_o}$$

from input port,

$$I_\varepsilon = -I_f = -\beta V_o$$

from output port,

$$I_o = \frac{V_o - A I_\varepsilon}{r_o} = \frac{V_o + T V_o}{r_o}$$

$$\Rightarrow R_{\text{out}} = \frac{V_o}{I_o} = \frac{r_o}{(1+T)}$$

# Feedback Structure (Shunt-Series)

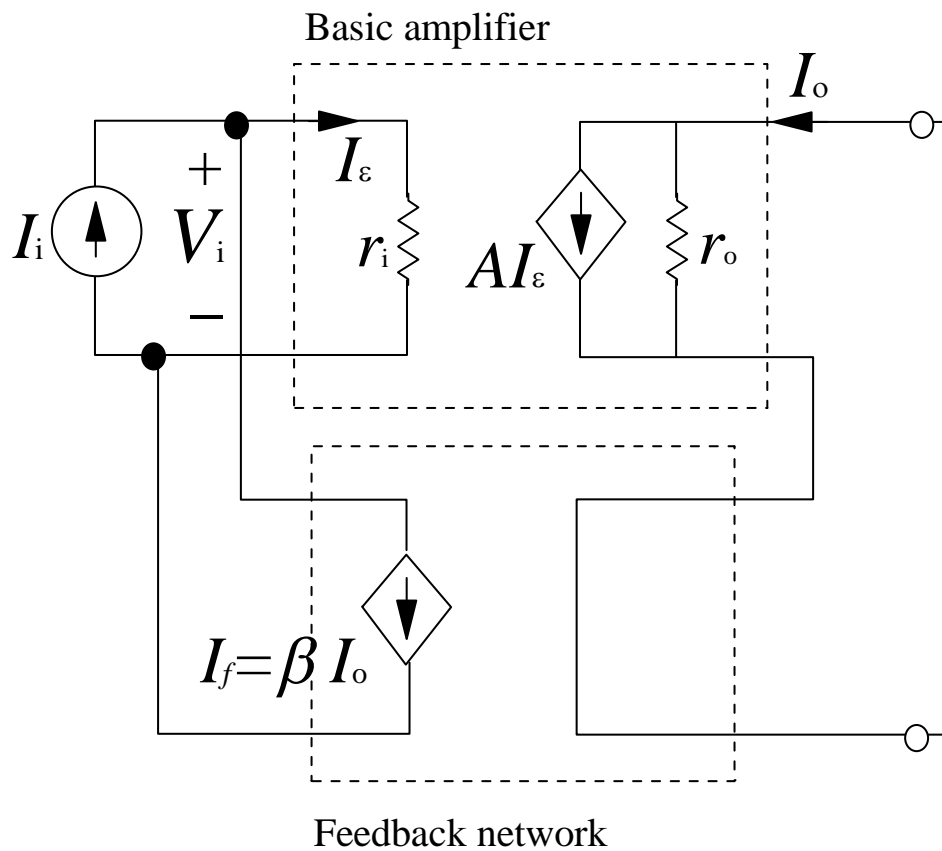

Gain Calculation :

$$I_o = A \cdot I_\varepsilon = A(I_i - I_f)$$

$$I_f = \beta \cdot I_o$$

$$A(I_i - \beta I_o) = I_o$$

$$A I_i = (1 + T) I_o$$

(Close Loop Current Gain)

$$\Rightarrow A_{CL} = \frac{I_o}{I_i} = \frac{1}{\beta} \left( \frac{T}{1+T} \right)$$

where  $T = A\beta$

And, we get

$$I_o = \frac{I_i \cdot A}{1 + A \cdot \beta}$$

$$I_i = I_\varepsilon (1 + A \cdot \beta)$$



# Input/Output Resistance (Shunt-Series)

Input Resistance:

$$\begin{aligned} R_{\text{in}} &= \frac{V_i}{I_i} = \frac{I_\varepsilon r_i}{I_i} \\ &= \frac{I_i}{(1+T)} \cdot r_i \\ &= \frac{r_i}{(1+T)} \end{aligned}$$

Output Resistance

(Closed loop output resistance with zero input voltage)

$$R_{\text{out}} \big|_{V_i=0} = \frac{V_o}{I_o}$$

from input port,

$$I_\varepsilon = -I_f = -\beta I_o$$

from output port,  $I_o = V_o / r_o + A I_\varepsilon$

$$V_o = (I_o - A I_\varepsilon) r_o$$

$$V_o = (I_o + T \cdot I_o) r_o$$

$$\Rightarrow R_{\text{out}} = \frac{V_o}{I_o} = (1+T) r_o$$

# Summary

Feedback Structure	Close loop gain	Input impedance	Output impedance	Parameter used
Series-Shunt	$\frac{V_o}{V_i} = \frac{1}{\beta} \left( \frac{T}{1+T} \right)$	$R_{in} = (1+T) \cdot r_i$	$R_{out} = \frac{r_o}{1+T}$	<i>h</i> -parameter
Series-Series	$\frac{I_o}{V_i} = \frac{1}{\beta} \left( \frac{T}{1+T} \right)$	$R_{in} = (1+T) \cdot r_i$	$R_{out} = (1+T) \cdot r_o$	<i>z</i> -parameter
Shunt-Shunt	$\frac{V_o}{I_i} = \frac{1}{\beta} \left( \frac{T}{1+T} \right)$	$R_{in} = \frac{r_i}{1+T}$	$R_{out} = \frac{r_o}{1+T}$	<i>y</i> -parameter
Shunt-Series	$\frac{I_o}{I_i} = \frac{1}{\beta} \left( \frac{T}{1+T} \right)$	$R_{in} = \frac{r_i}{1+T}$	$R_{out} = (1+T) \cdot r_o$	<i>g</i> -parameter