

Data Communications and Computer Networks: A Business User's Approach

Multiplexing : Sharing a Medium

Data Communications and Computer Networks

Last time

Making connections

- Synchronous vs asynchronous (temporal)
- Duplex vs simplex (directional)

Continue making connections – multiplexing

- Many into one; one into many (spatial)
 - Will use time and frequency to do it.

Introduction

Under the simplest conditions, a medium can carry only one signal at any moment in time.

For multiple signals to share one medium, the medium must somehow be divided, giving each signal a portion of the total bandwidth.

The current techniques that can accomplish this include

- frequency division multiplexing (FDM)
- time division multiplexing (TDM)
 - Synchronous vs statistical
- wavelength division multiplexing (WDM)
- code division multiplexing (CDM)

Multiplexing

Multiplexor (MUX)

Demultiplexor (DEMUX)

Sometimes just called a MUX

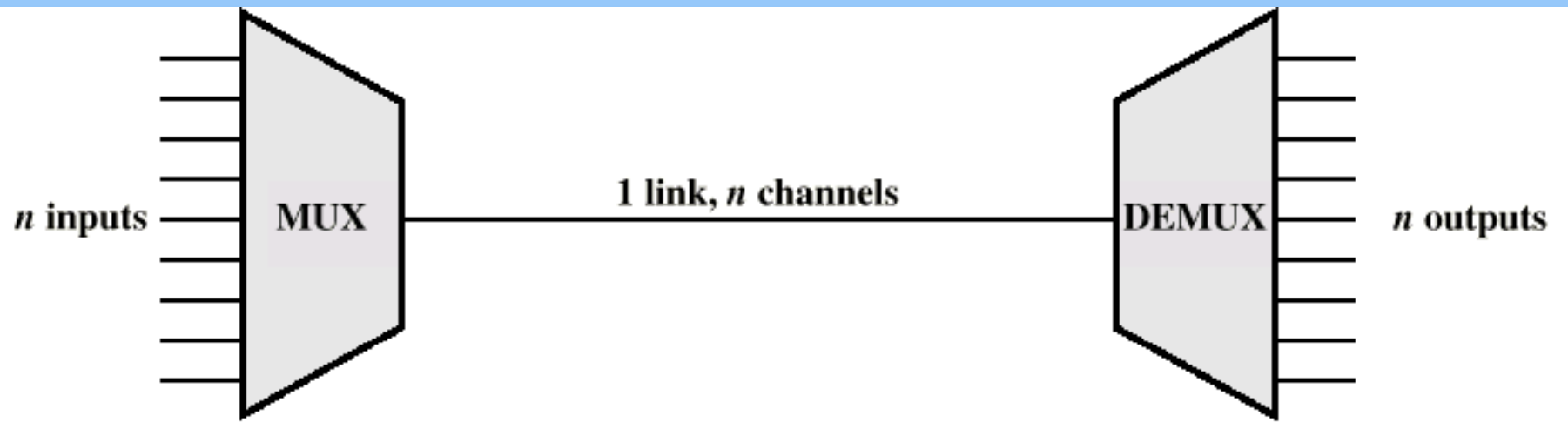

Multiplexing

- Two or more simultaneous transmissions on a single circuit.
 - Transparent to end user.
- *Multiplexing costs less.*

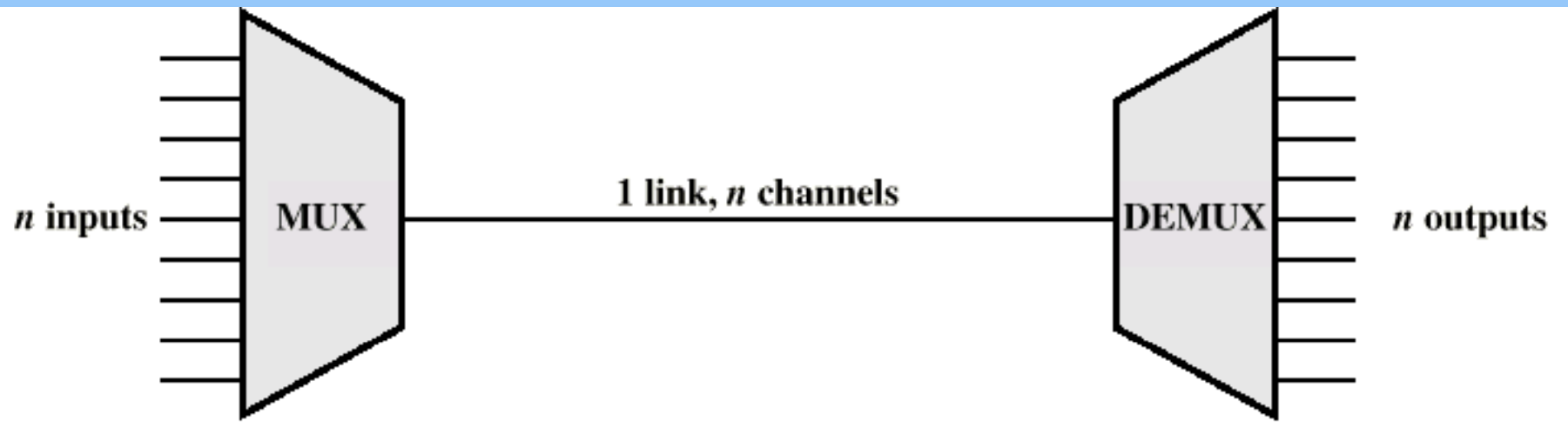

Data Communications and Computer Networks

Frequency Division Multiplexing

Assignment of non-overlapping frequency ranges to each “user” or signal on a medium. Thus, all signals are transmitted at the same time, each using different frequencies.

A multiplexor accepts inputs and assigns frequencies to each device.

The multiplexor is attached to a high-speed communications line.

A corresponding multiplexor, or demultiplexor, is on the end of the high-speed line and separates the multiplexed signals. 6

Data Communications and Computer Networks

Figure 5-1
*Simplified example of
frequency division
multiplexing*

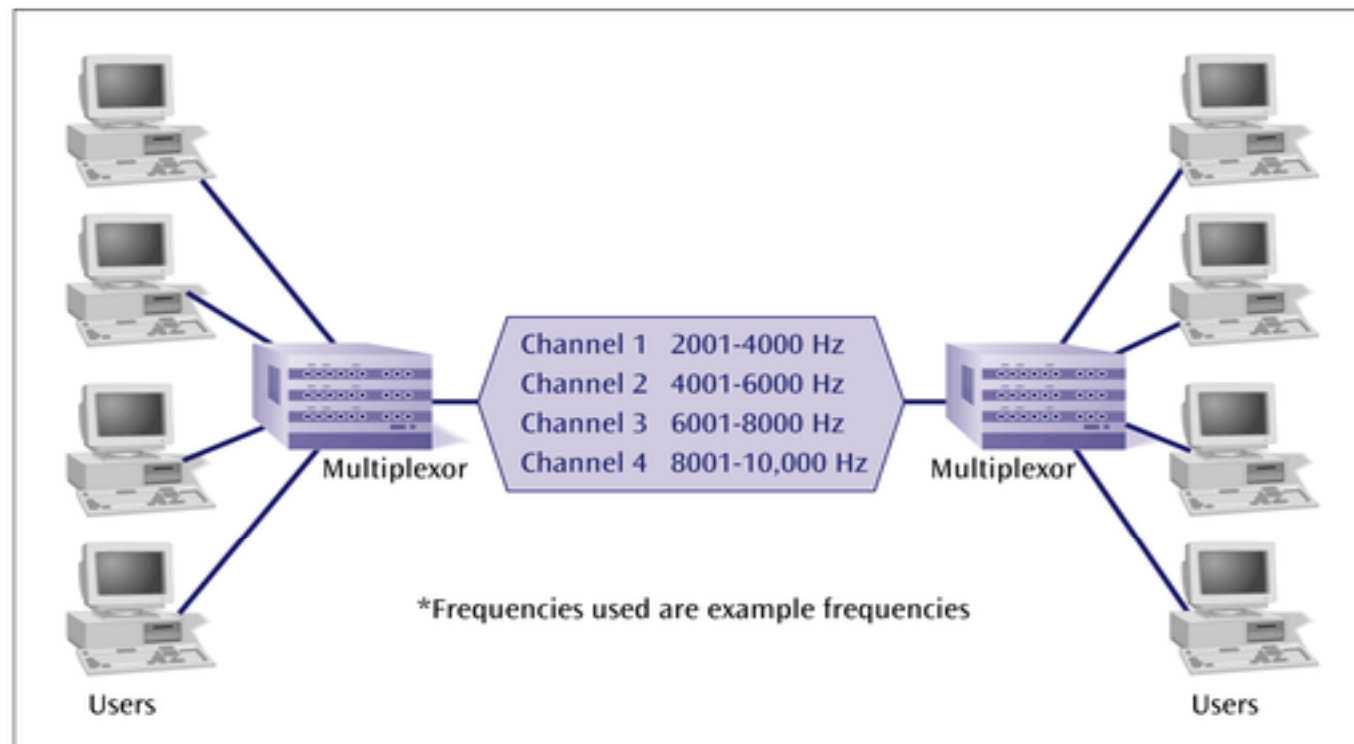

Data Communications and Computer Networks

Frequency Division Multiplexing

Analog signaling is used to transmits the signals.

Broadcast radio and television, cable television, and the AMPS cellular phone systems use frequency division multiplexing.

This technique is the oldest multiplexing technique.

Since it involves analog signaling, it is more susceptible to noise.

Table 5-1
Assignment of frequencies for cable television channels

	Channel	Frequency in MHz
Low-Band VHF and Cable	2	54–60
	3	60–66
	4	66–72
	5	76–82
	6	82–88
	Mid-Band Cable	95
96		96–102
97		102–108
98		108–114
99		114–120
14		120–126
15		126–132
16		132–138
17		138–144
18		144–150
19		150–156
20		156–162
21		162–168
22		168–174
High-Band VHF and Cable	7	174–180
	8	180–186
	9	186–192
	10	192–198
	11	198–204
	12	204–210
	13	210–216

Data Communications and Computer Networks

Time Division Multiplexing

Sharing of the signal is accomplished by dividing available transmission time on a medium among users.

Digital signaling is used exclusively.

Time division multiplexing comes in two basic forms:

1. Synchronous time division multiplexing, and
2. Statistical, or asynchronous time division multiplexing.

Data Communications and Computer Networks

Synchronous Time Division Multiplexing

The original time division multiplexing.

The multiplexor accepts input from attached devices in a round-robin fashion and transmit the data in a never ending pattern.

T-1 and ISDN telephone lines are common examples of synchronous time division multiplexing.

Data Communications and Computer Networks

Figure 5-2
*Sample output stream
generated by a syn-
chronous time division
multiplexor*

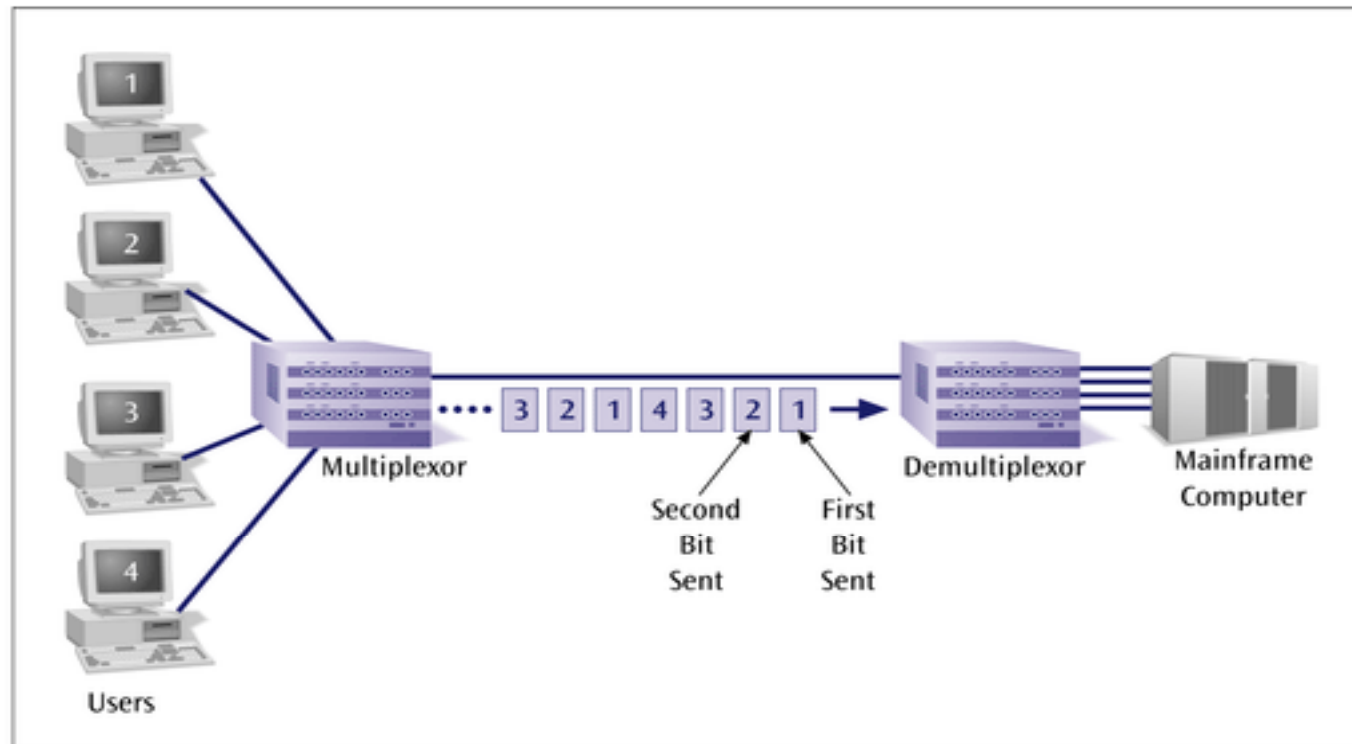

Synchronous Time Division Multiplexing

If one device generates data at a faster rate than other devices, then the multiplexor must either sample the incoming data stream from that device more often than it samples the other devices, or buffer the faster incoming stream.

If a device has nothing to transmit, the multiplexor must still insert a piece of data from that device into the multiplexed stream.

Data Communications and Computer Networks

Figure 5-3

A synchronous time division multiplexor system which samples device A twice as fast as the other devices

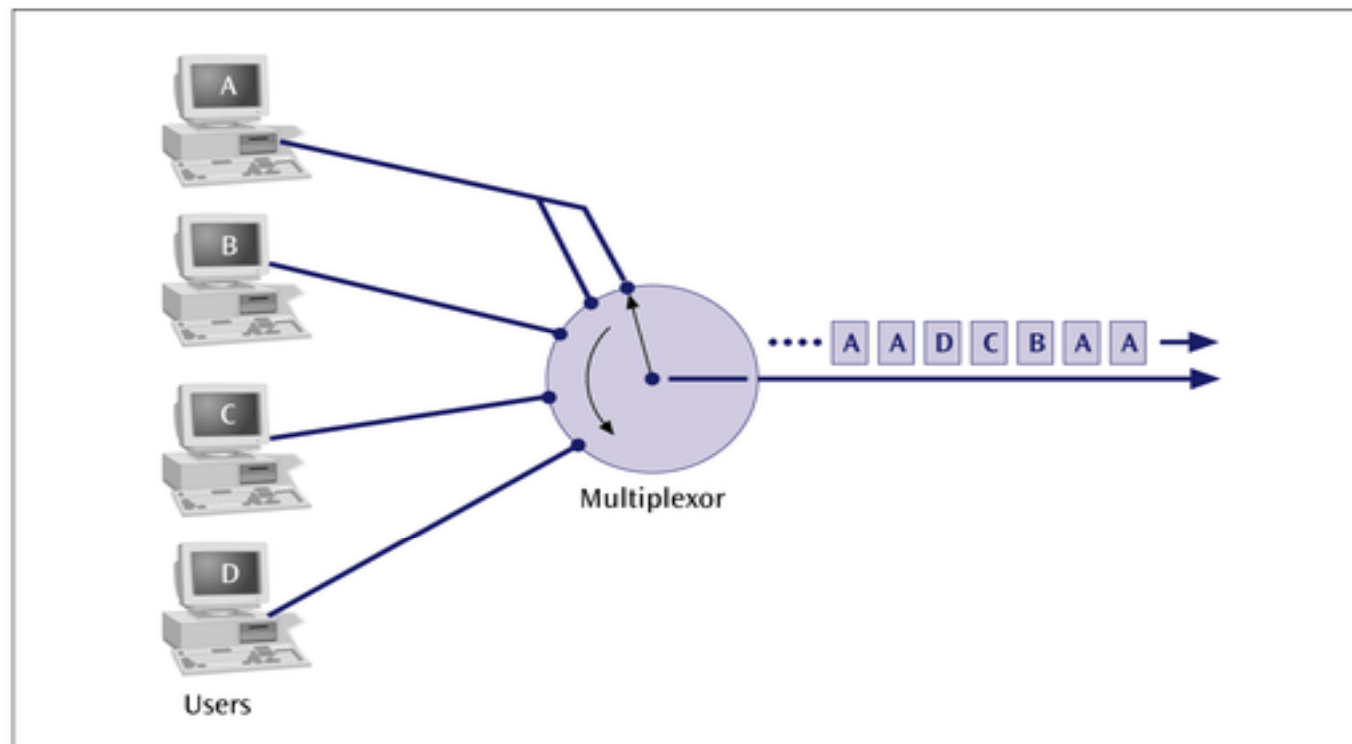
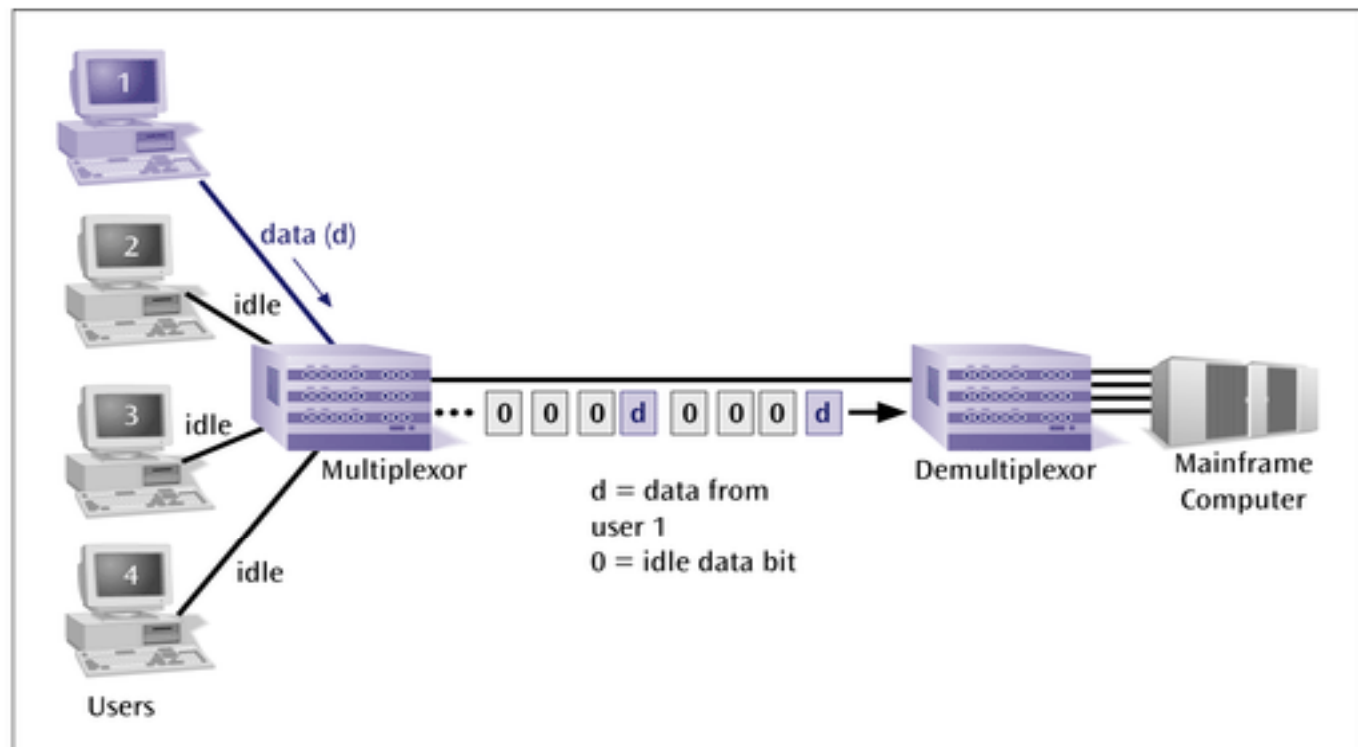

Figure 5-4
Multiplexor transmission stream with only one input device transmitting data



Synchronous time division multiplexing

So that the receiver may stay synchronized with the incoming data stream, the transmitting multiplexor can insert alternating 1s and 0s into the data stream.

Figure 5-5
*Transmitted frame
with added synchro-
nization bits*

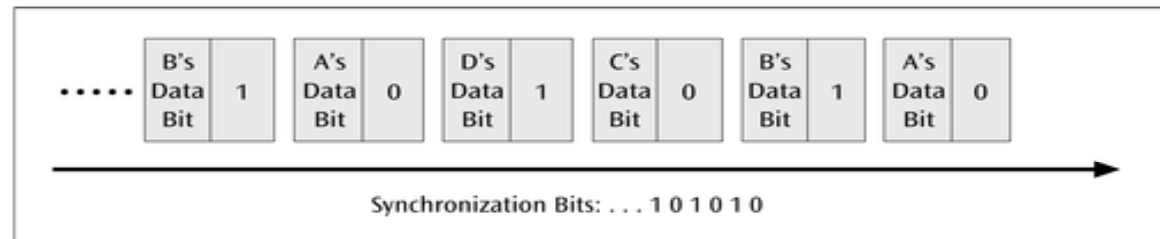

Data Communications and Computer Networks

Synchronous Time Division Multiplexing

Three types popular today:

- T-1 multiplexing (the classic)
- ISDN multiplexing
- SONET (Synchronous Optical NETWORKwork)

The T1 (1.54 Mbps) multiplexor stream is a *continuous* series of frames of both digitized data and voice channels.

Figure 5-6
T1 multiplexed data stream

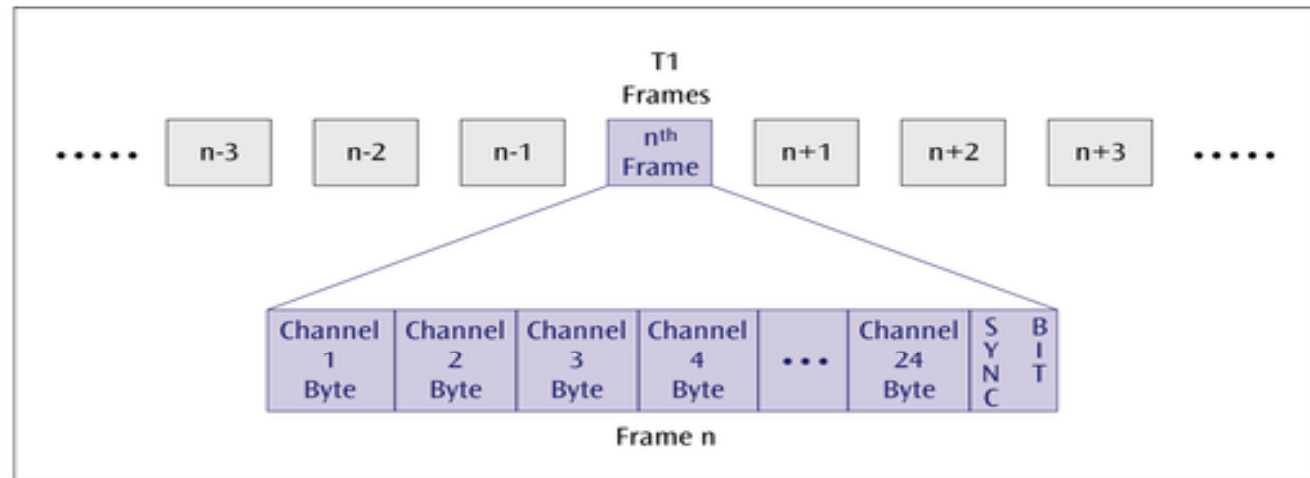

24 separate 64Kbps channels

Data Communications and Computer Networks

The ISDN multiplexor stream is also a continuous stream of frames. Each frame contains various control and sync info.

Figure 5-8
ISDN frame layout showing B channel bits and signaling control information bits

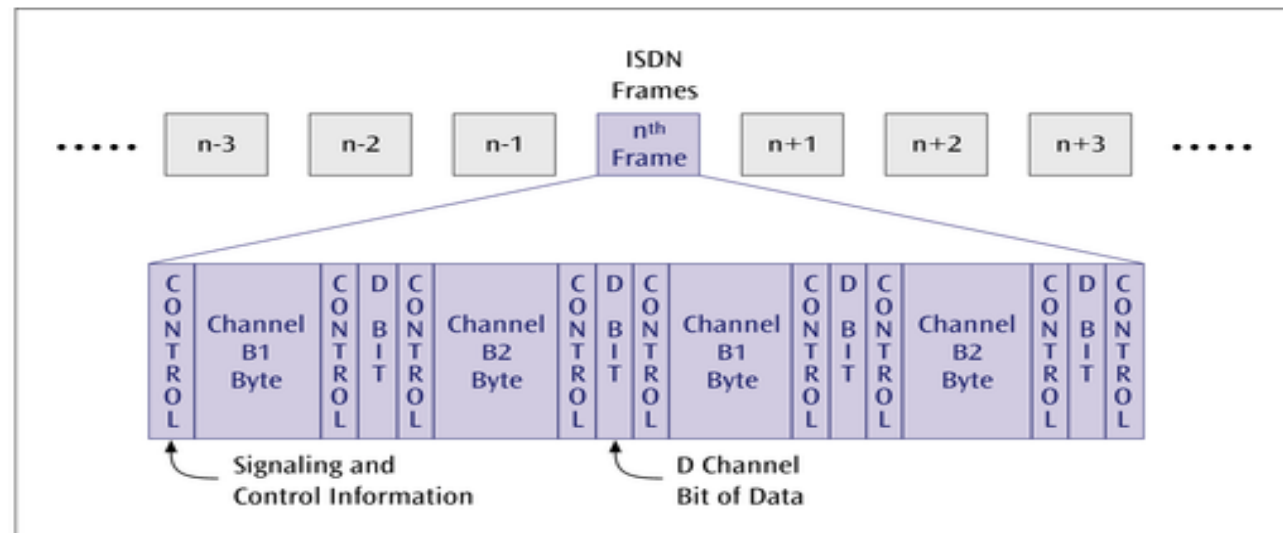

Data Communications and Computer Networks

SONET – massive data rates

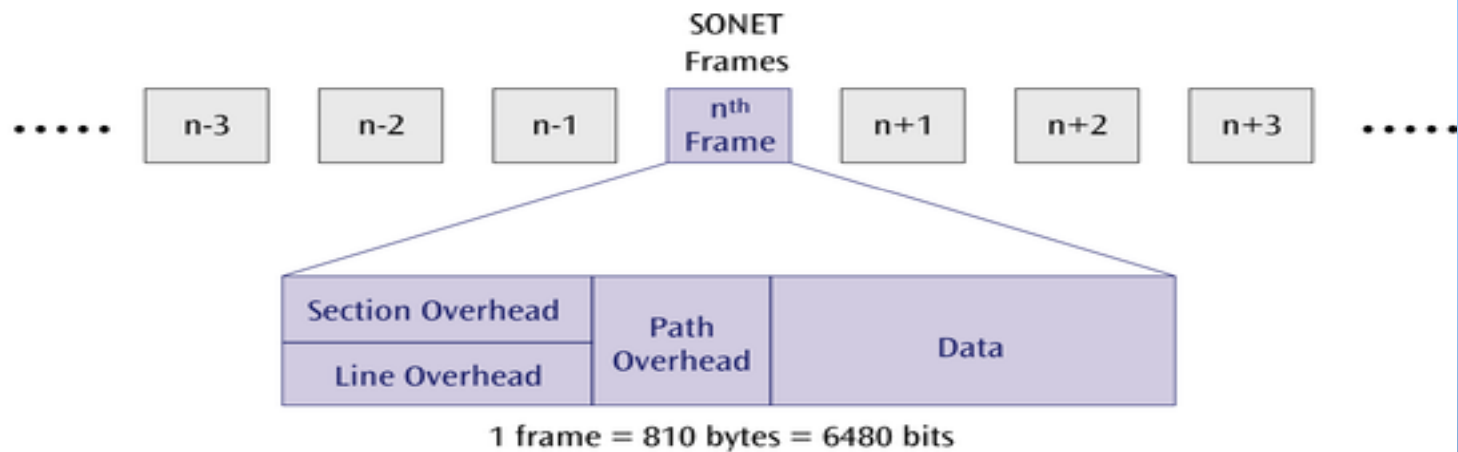

Figure 5-7 SONET STS-1 frame layout

Synchronous TDM

- Very popular
- Line will require as much bandwidth as all the bandwidths of the sources

Data Communications and Computer Networks

Statistical Time Division Multiplexing

A statistical multiplexor transmits only the data from active workstations (*or why work when you don't have to*).

If a workstation is not active, no space is wasted on the multiplexed stream.

A statistical multiplexor accepts the incoming data streams and creates a frame containing only the data to be transmitted.

Data Communications and Computer Networks

Figure 5-9
Two stations out of four transmitting via a statistical multiplexor

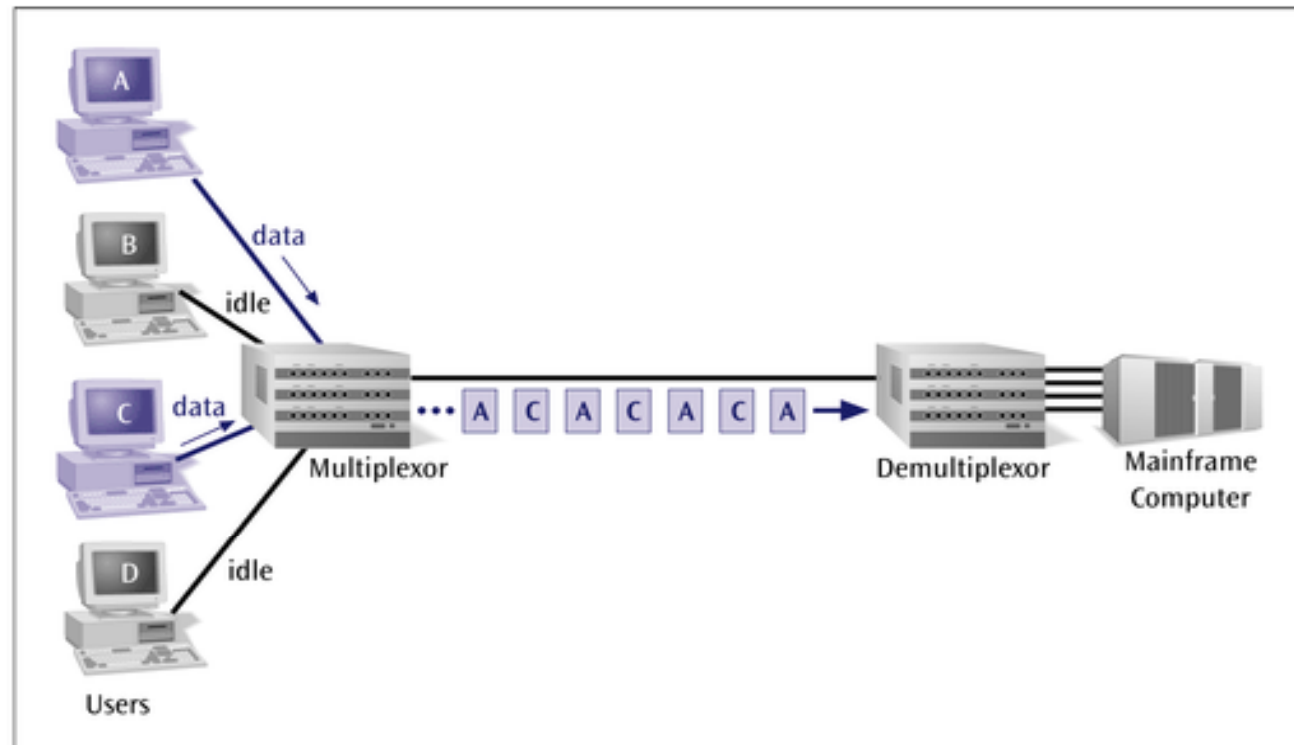

Data Communications and Computer Networks

To identify each piece of data, an address is included.

Figure 5-10
Sample address and data in a statistical multiplexor output stream

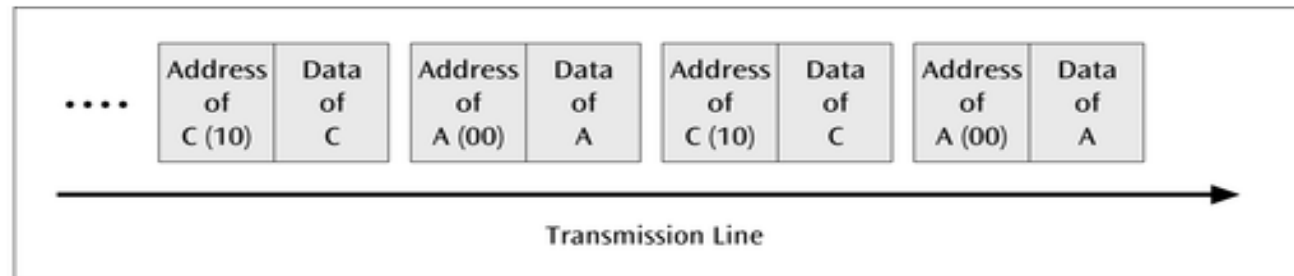

Data Communications and Computer Networks

If the data is of variable size, a length is also included.

Figure 5-11
Packets of address and data fields in a statistical multiplexor output stream

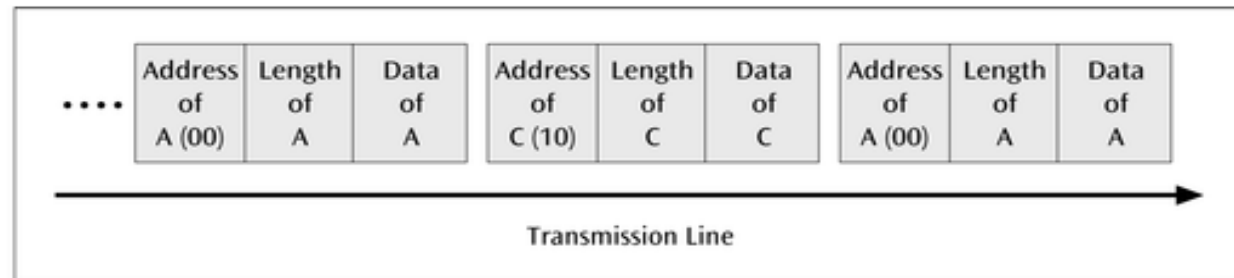

Data Communications and Computer Networks

More precisely, the transmitted frame contains a collection of data groups.

Figure 5-12
Frame layout for the information packet transferred between statistical multiplexors

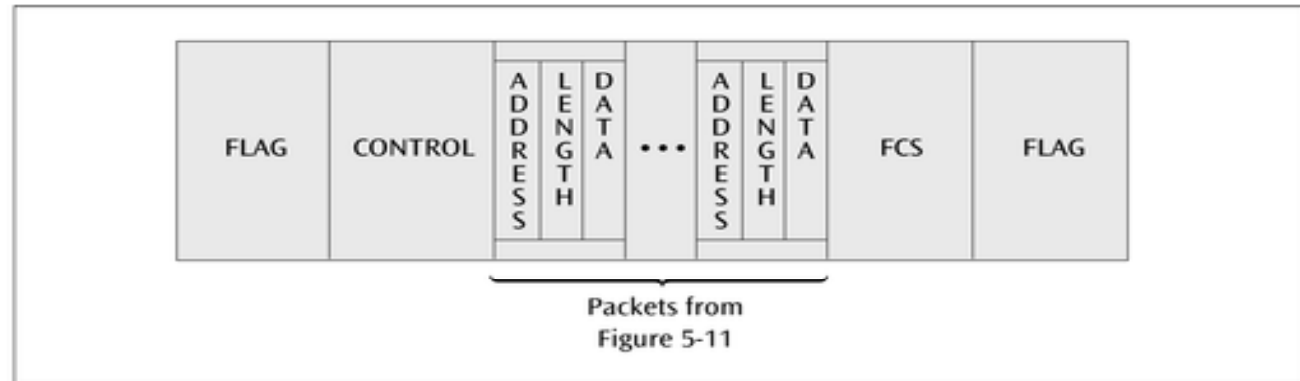

Data Communications and Computer Networks

Statistical Time Division Multiplexing

A statistical multiplexor does not require a line over as high a speed line as synchronous time division multiplexing since STDM does not assume all sources will transmit all of the time!

Good for low bandwidth lines (used for LANs)

Much more efficient use of bandwidth!

Data Communications and Computer Networks

Wavelength Division Multiplexing (WDM)

Give each message a different wavelength (frequency)

Easy to do with fiber optics and optical sources

Dense Wavelength Division Multiplexing (DWDM)

Dense wavelength division multiplexing is often called just wavelength division multiplexing

Dense wavelength division multiplexing multiplexes multiple data streams onto a single fiber optic line.

Different wavelength lasers (called lambdas) transmit the multiple signals.

Each signal carried on the fiber can be transmitted at a different rate from the other signals.

Dense wavelength division multiplexing combines many (30, 40, 50, 60, more?) onto one fiber.

Data Communications and Computer Networks

Figure 5-13
Multiple lasers transmitting data signals down a single fiber optic line

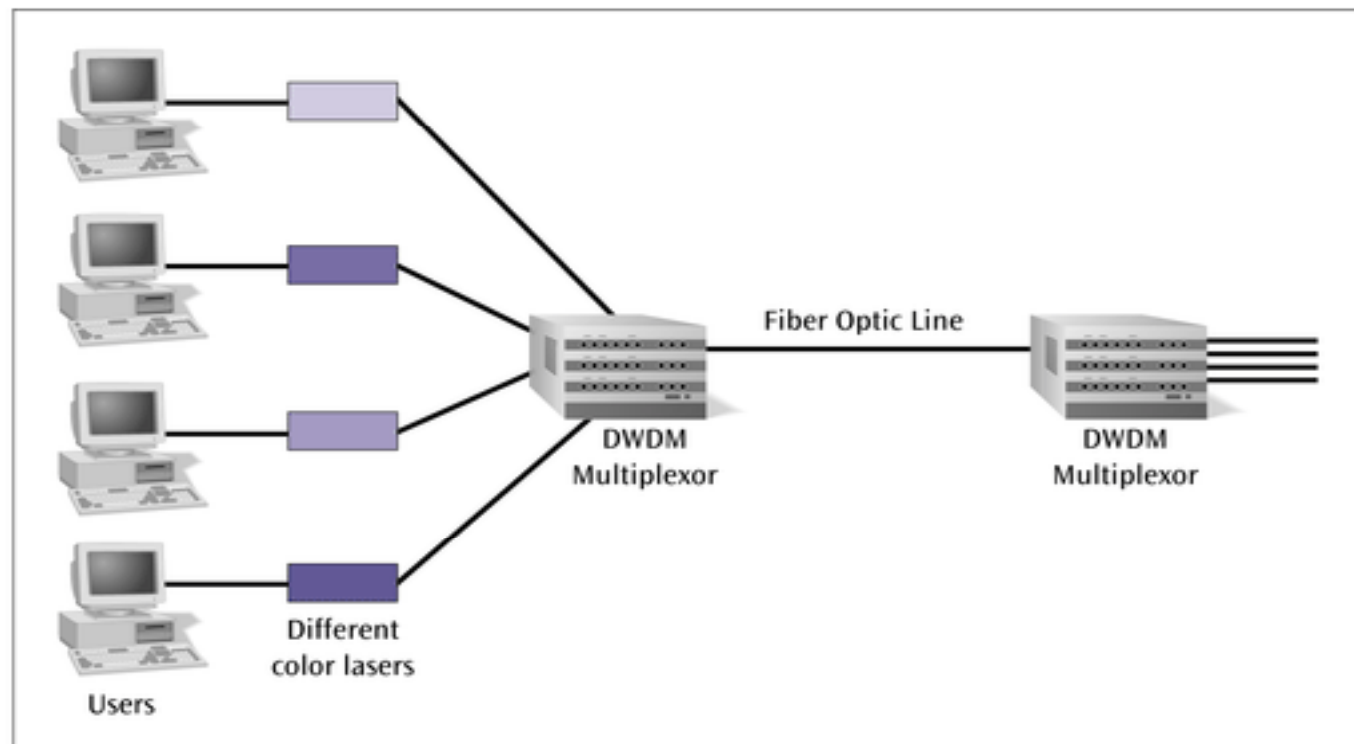

Data Communications and Computer Networks

Figure 5-14

Fiber optic line using dense wavelength division multiplexing and supporting multiple-speed transmissions

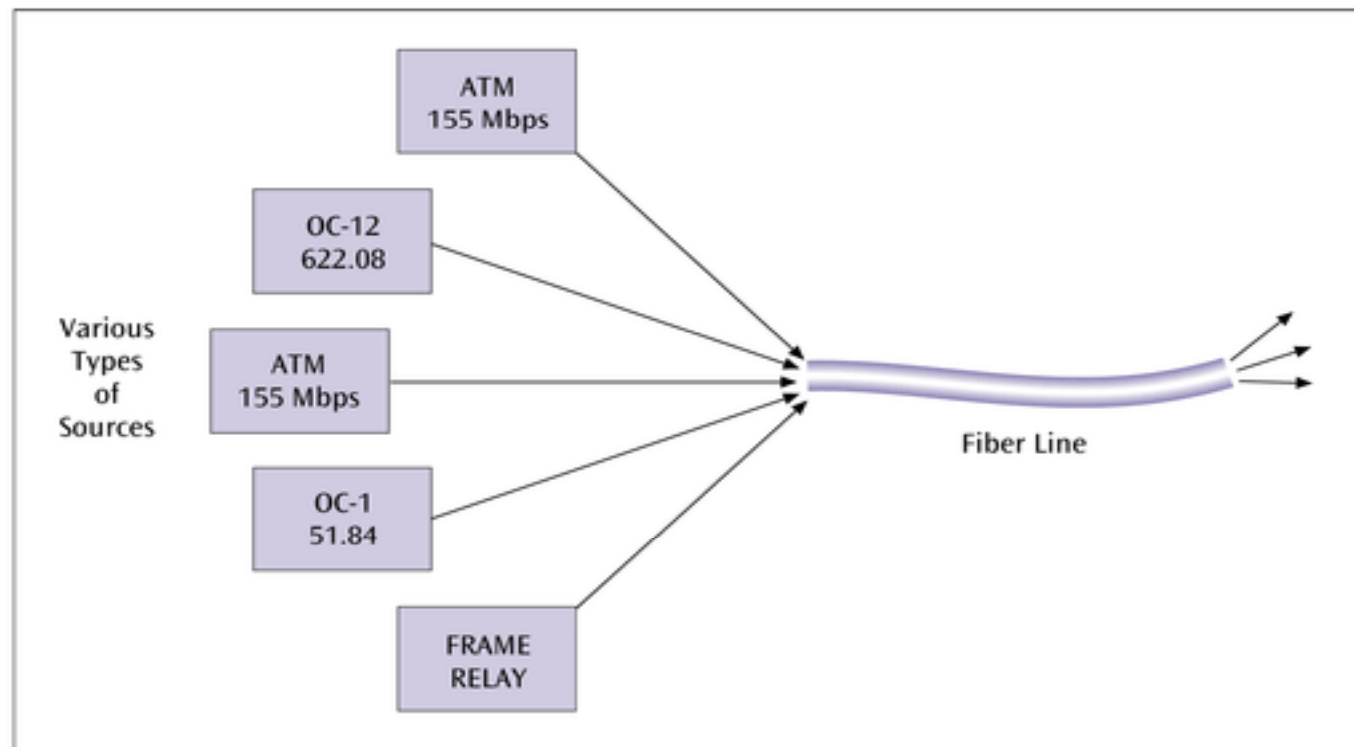

Data Communications and Computer Networks

Code Division Multiplexing (CDM)

Old but now new method

Also known as code division multiple access (CDMA)

An advanced technique that allows multiple devices to transmit on the *same* frequencies at the *same* time using different codes

Used for mobile communications

Data Communications and Computer Networks

Code Division Multiplexing

An advanced technique that allows multiple devices to transmit on the *same* frequencies at the *same* time.

Each mobile device is assigned a unique 64-bit code (chip spreading code)

To send a binary 1, mobile device transmits the unique code

To send a binary 0, mobile device transmits the inverse of code

Data Communications and Computer Networks

Code Division Multiplexing

Receiver gets summed signal, multiplies it by receiver code, adds up the resulting values

Interprets as a binary 1 if sum is near +64

Interprets as a binary 0 if sum is near -64

Table 5-3*Advantages and disadvantages of multiplexing techniques*

Multiplexing Technique	Advantages	Disadvantages
Frequency Division Multiplexing	Simple Popular with radio, TV, cable TV Relatively inexpensive All the receivers, such as cellular telephones, do not need to be at the same location	Analog signals only Limited by frequency ranges
Synchronous Time Division Multiplexing	Digital signals Relatively simple Commonly used with T-1 and ISDN	Wastes bandwidth
Statistical Time Division Multiplexing	More efficient use of bandwidth Packets can be various sizes Frame can contain control and error information	More complex than synchronous time division multiplexing
Dense Wavelength Division Multiplexing	Very high capacities over fiber Scalable Signals can have varying speeds	Cost Complexity
Code Division Multiplexing	Large capacities Scalable	Complexity

Data Communications and Computer Networks

Business Multiplexing In Action

XYZ Corporation has two buildings separated by a distance of 300 meters.

A 3-inch diameter tunnel extends underground between the two buildings.

Building A has a mainframe computer and Building B has 66 terminals.

List some efficient techniques to link the two buildings.

Data Communications and Computer Networks

Figure 5-15
Buildings A and B and the 3-inch tunnel connecting the buildings

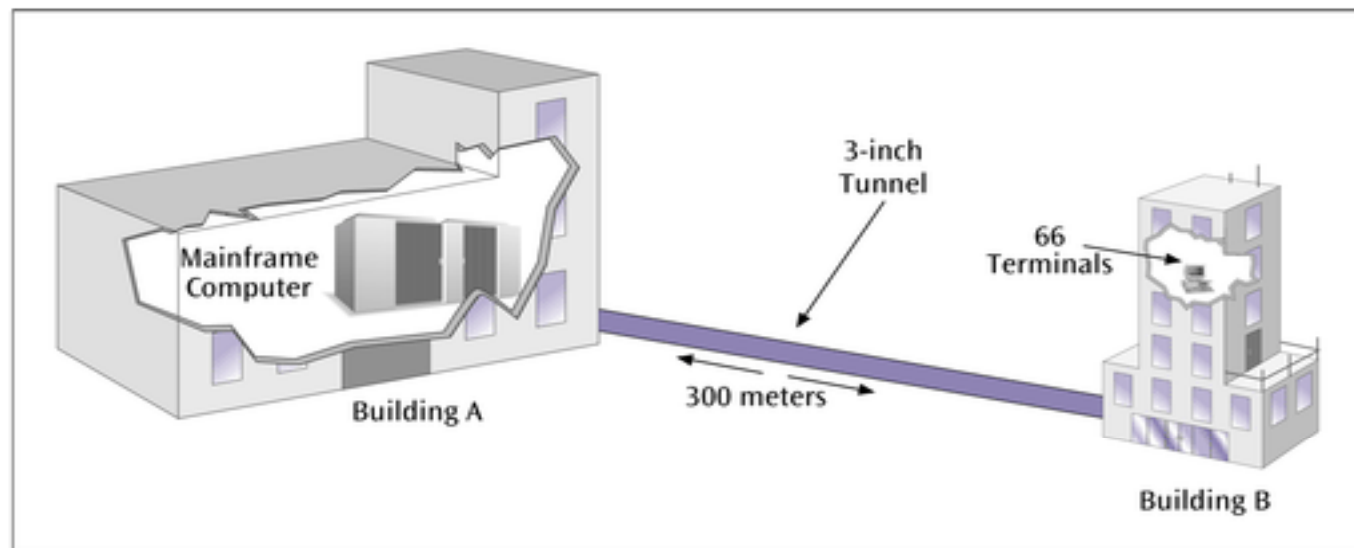

Data Communications and Computer Networks

Possible Solutions

Connect each terminal to the mainframe computer using separate point-to-point lines.

Connect all the terminals to the mainframe computer using one multipoint line.

Connect all the terminal outputs and use microwave transmissions to send the data to the mainframe.

Collect all the terminal outputs using multiplexing and send the data to the mainframe computer using a conducted line.

What did we cover

- Multiplexing
- Types of multiplexing
 - TDM
 - Synchronous TDM (T-1, ISDN, optical fiber)
 - Statistical TDM (LANs)
 - FDM (cable, cell phones, broadband)
 - WDM (optical fiber)
 - CDM (cell phones)