



Control Principles

Block diagram practice

Block diagram

Transfer Function

Consists of Blocks

Can be reduced

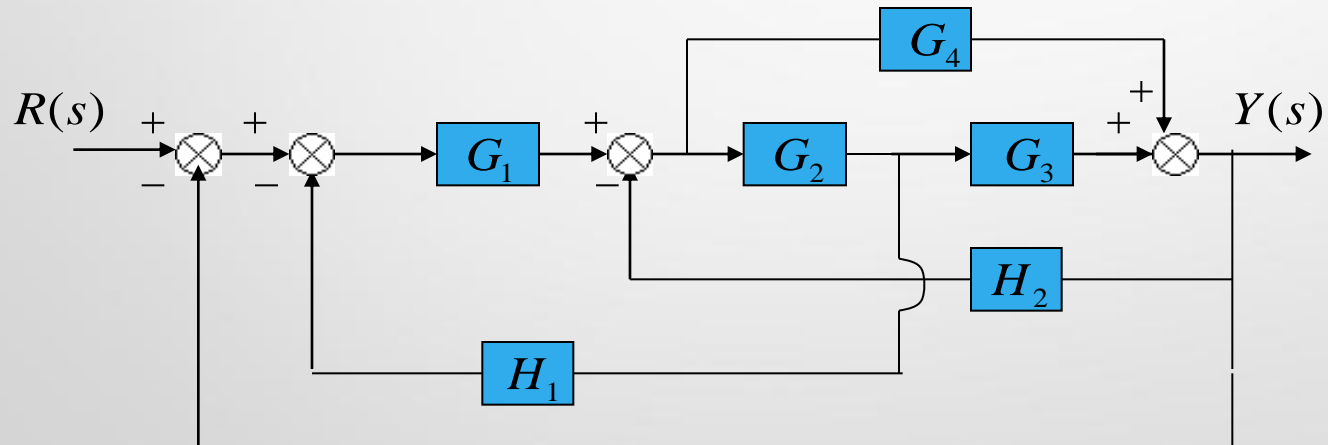

Reduction techniques

1. Combining blocks in cascade or in parallel

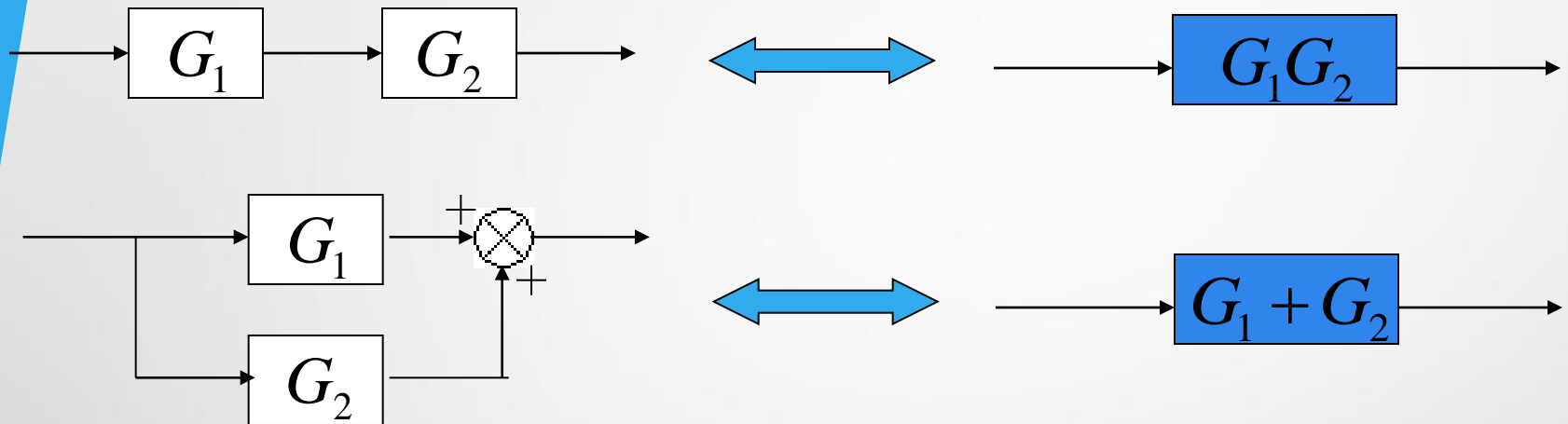

2. Moving a summing point behind a block

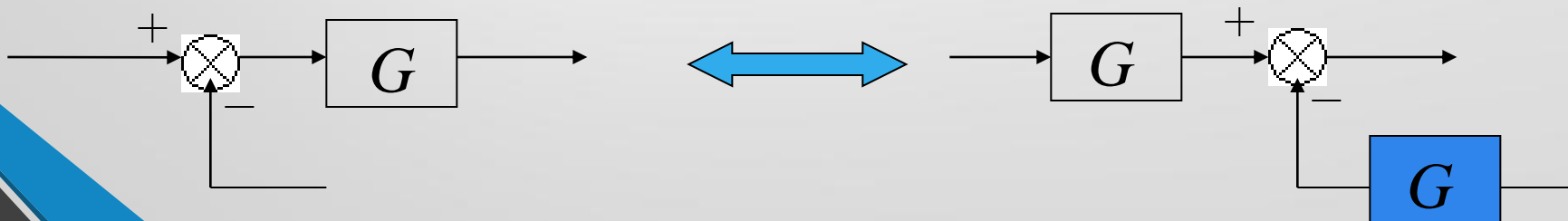

3. Moving a summing point ahead of a block

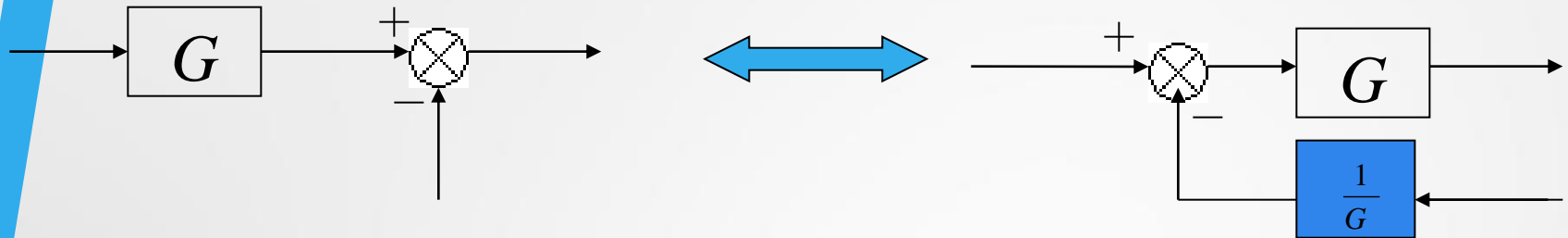

4. Moving a pickoff point behind a block

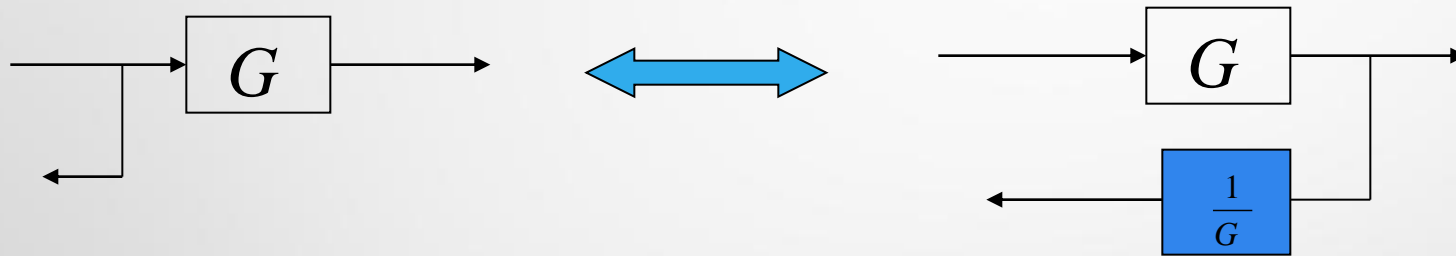

5. Moving a pickoff point ahead of a block

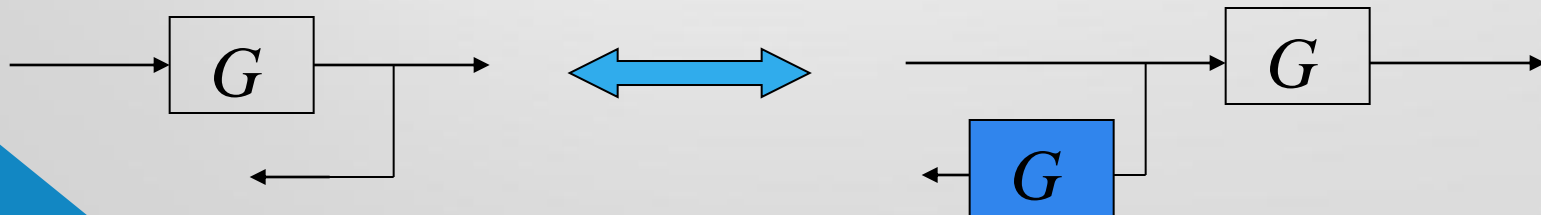

6. Eliminating a feedback loop

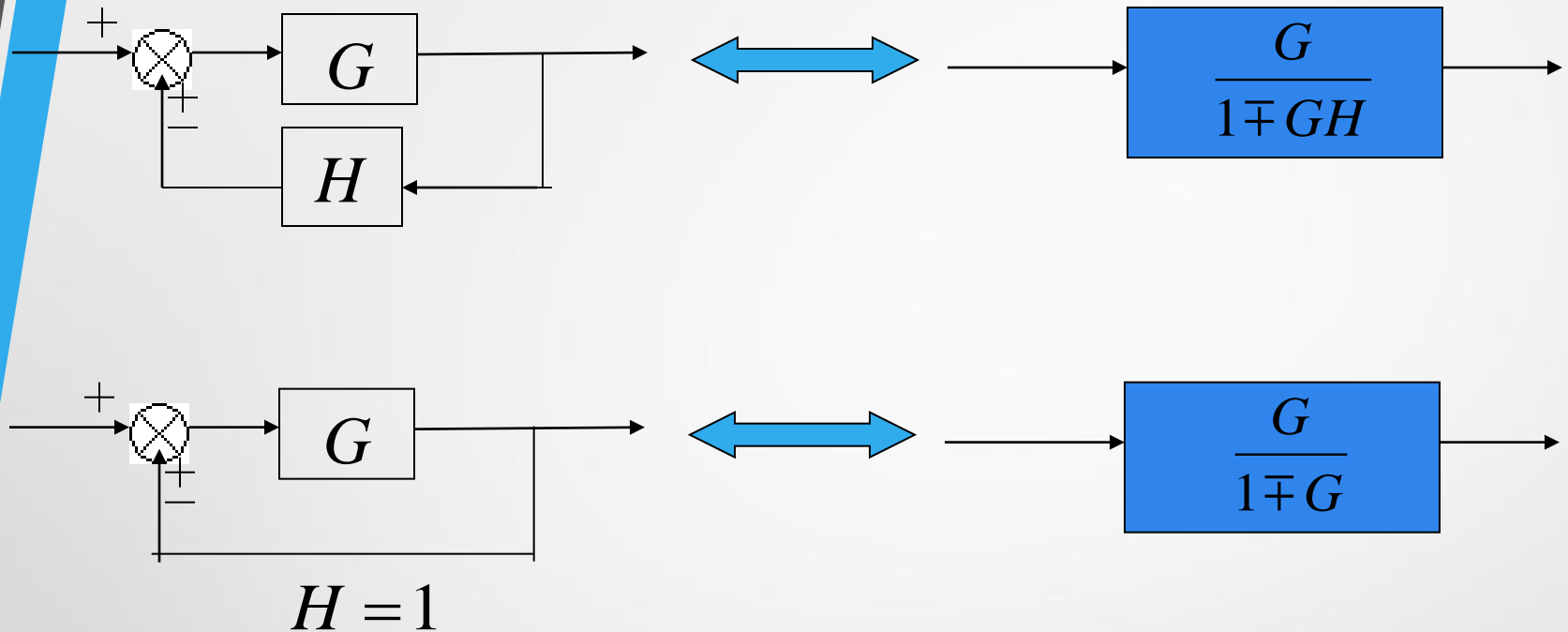

7. Swap with two neighboring summing points

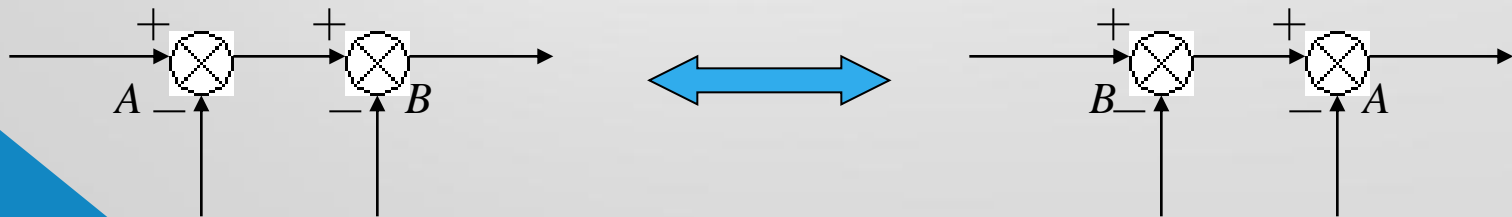

Example 1

Find the transfer function of the following block diagrams

(a)

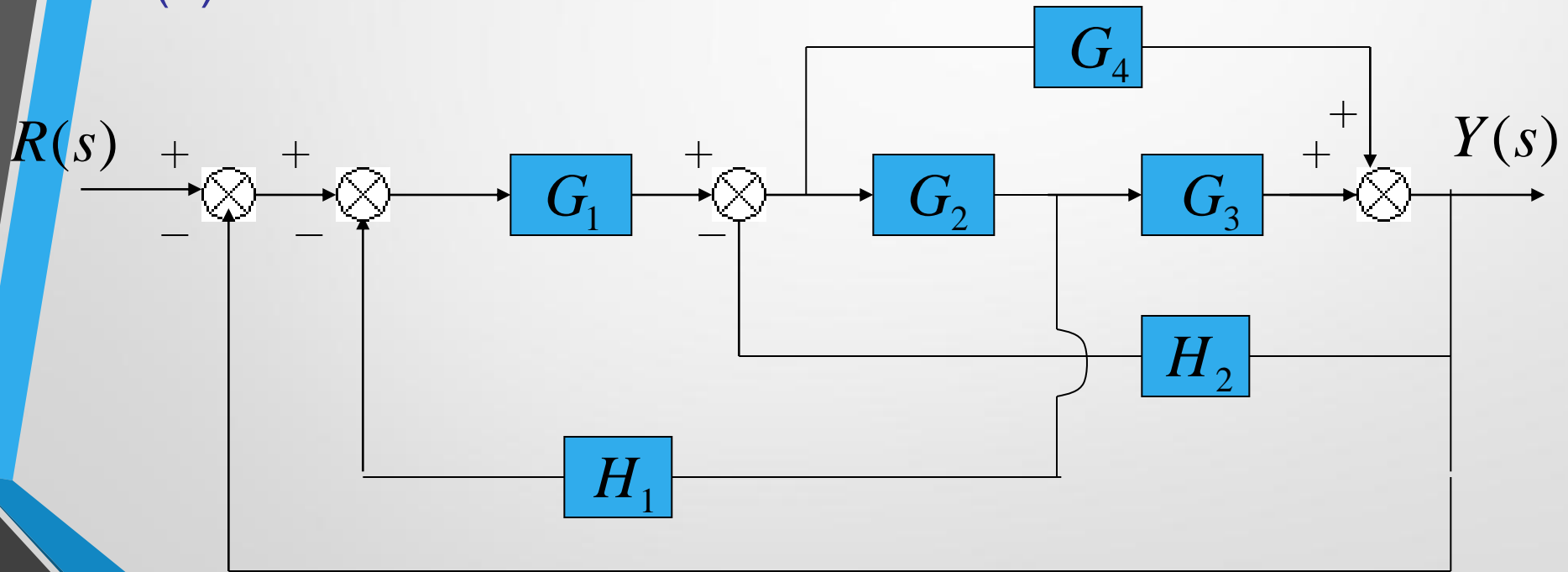

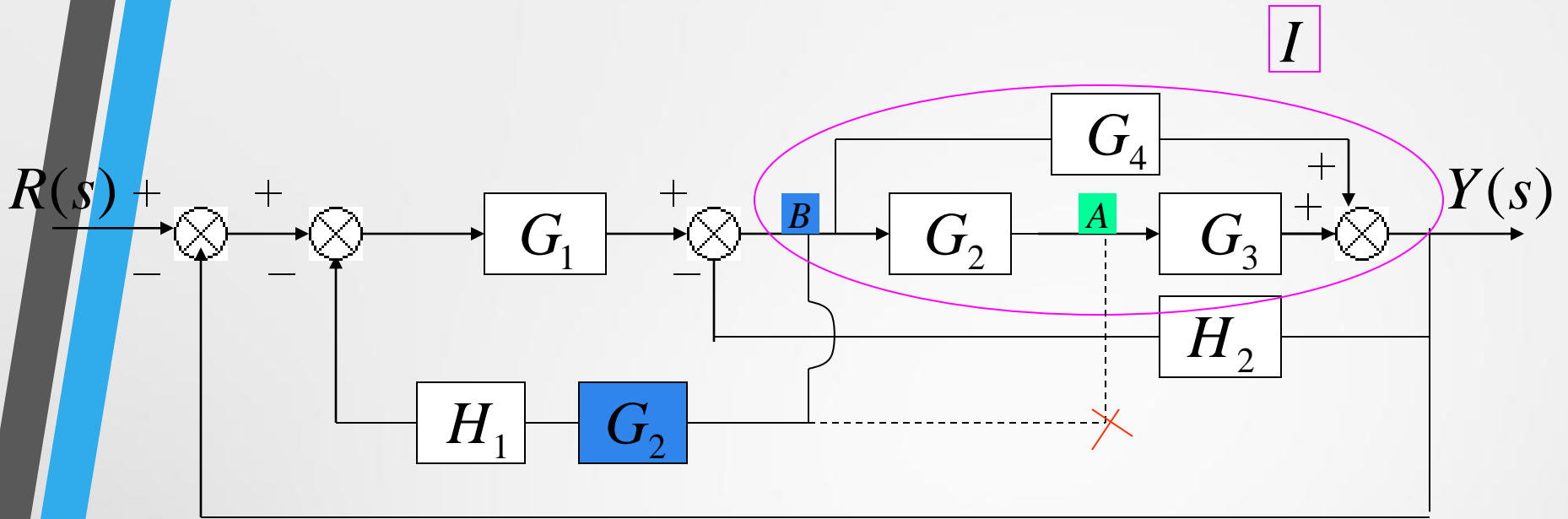

Solution:

1. Moving pickoff point A ahead of block G_2
2. Eliminate loop I & simplify

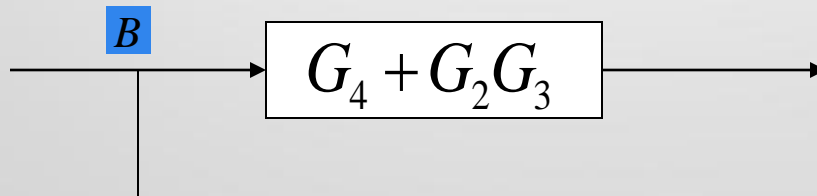

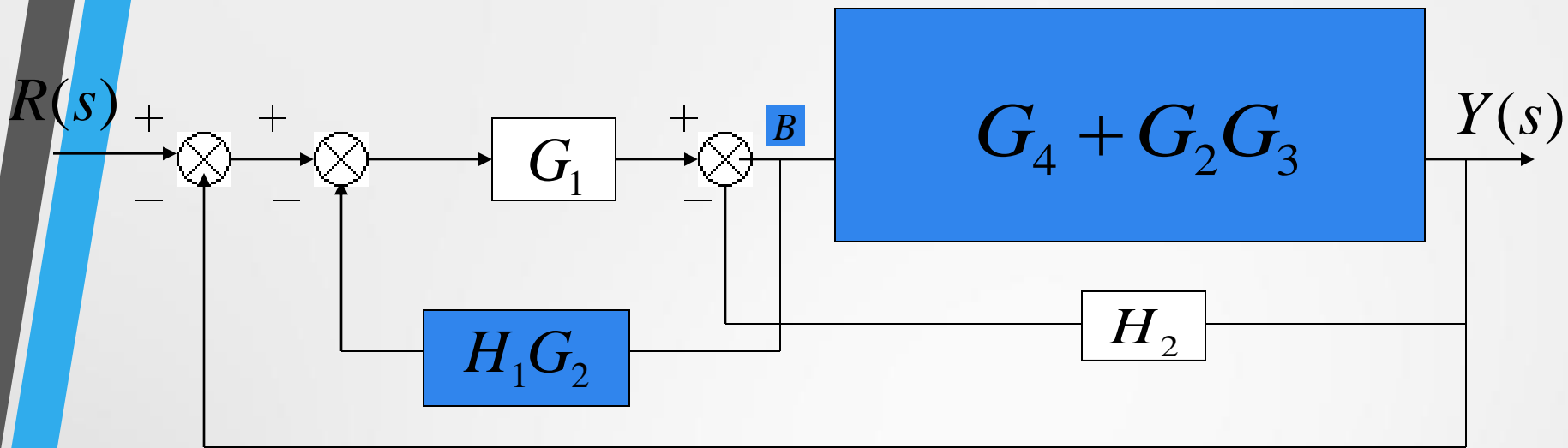

3. Moving pickoff point B behind block $G_4 + G_2G_3$

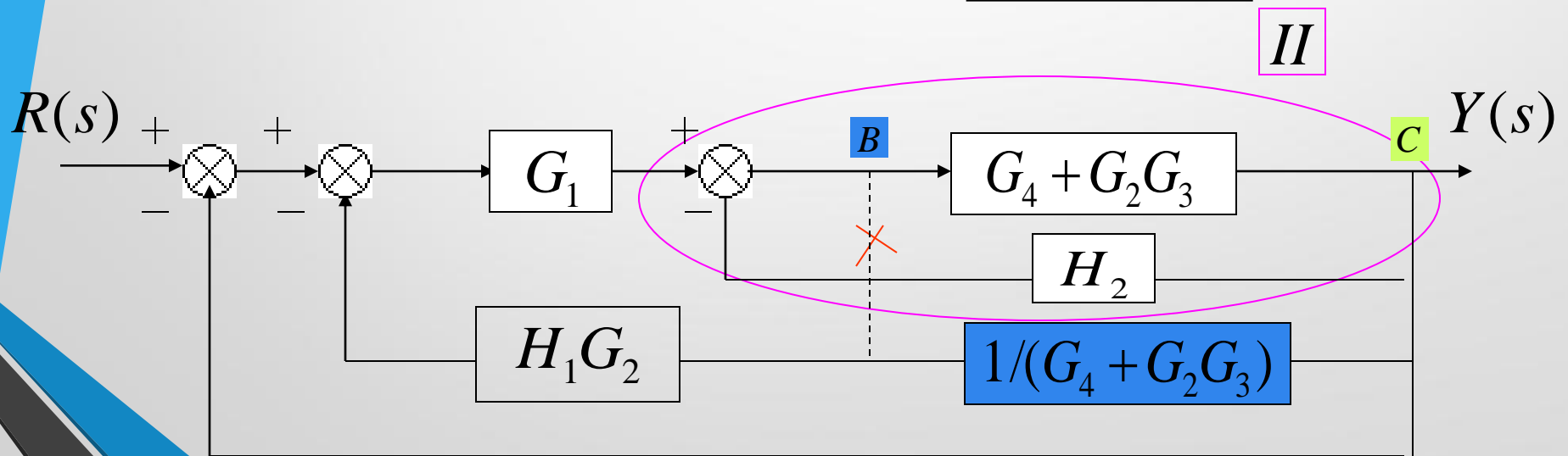

4. Eliminate loop III

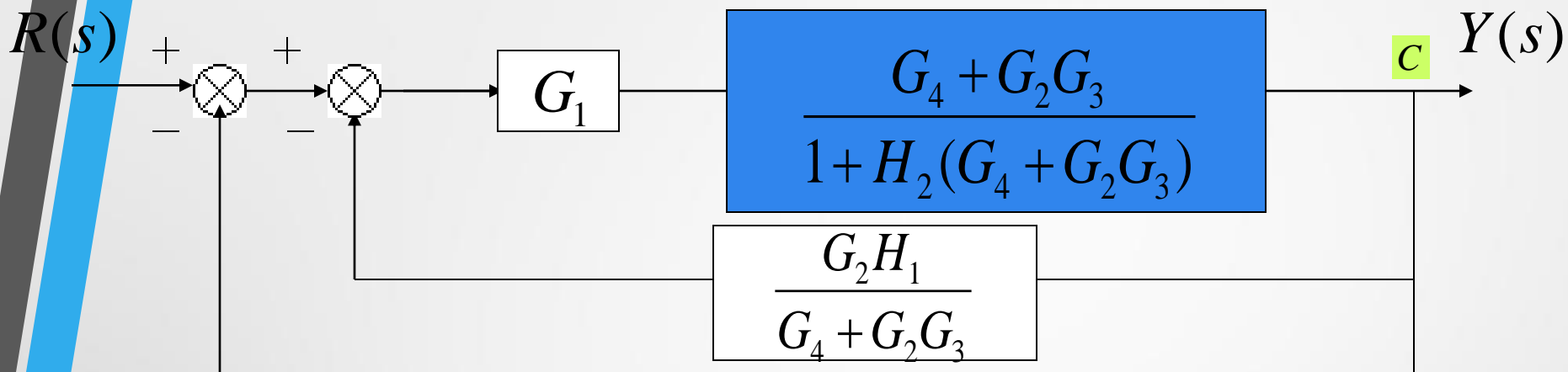

↓ Using rule 6

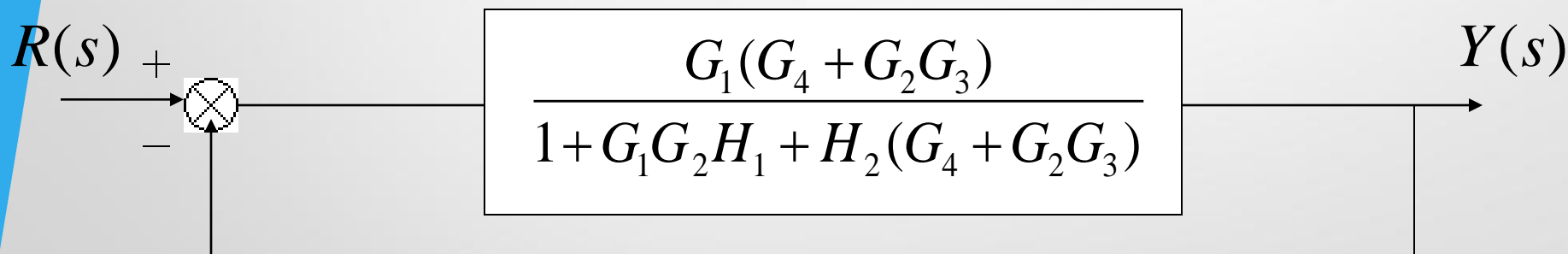

$$T(s) = \frac{Y(s)}{R(s)} = \frac{G_1(G_4 + G_2G_3)}{1 + G_1G_2H_1 + H_2(G_4 + G_2G_3) + G_1(G_4 + G_2G_3)}$$

(b)

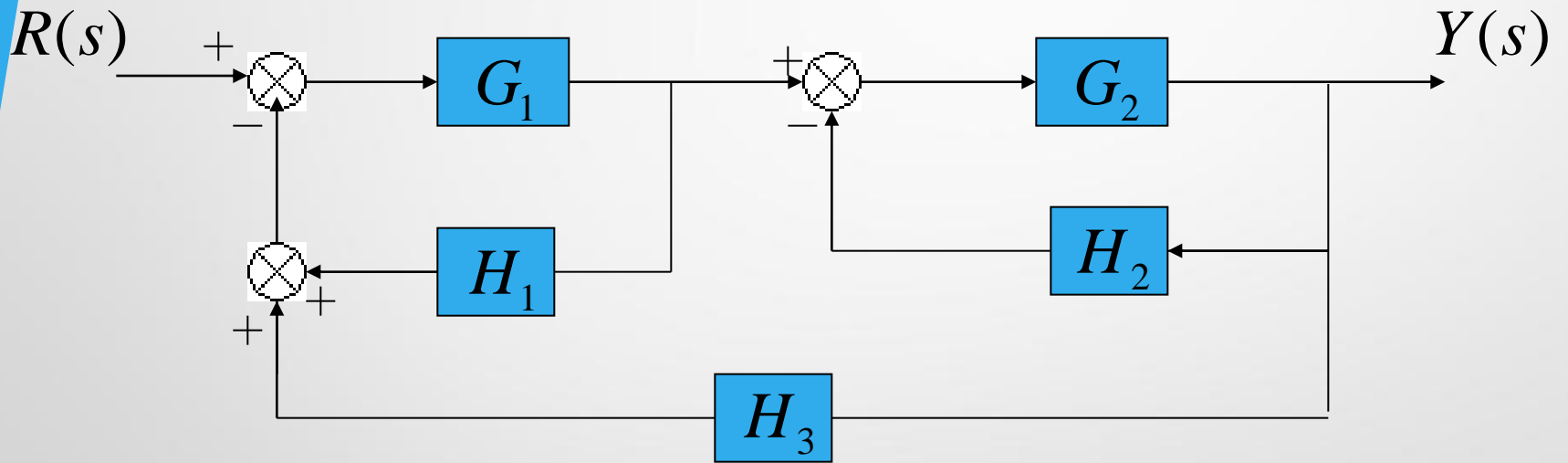

Solution:

1. Eliminate loop I

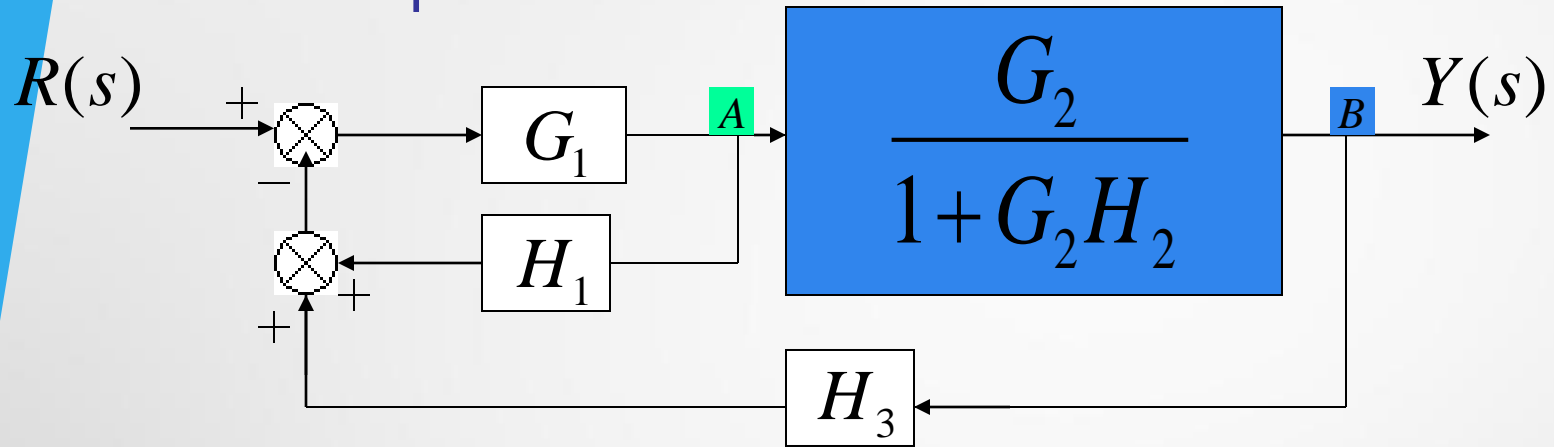

2. Moving pickoff point A behind block $\frac{G_2}{1+G_2H_2}$

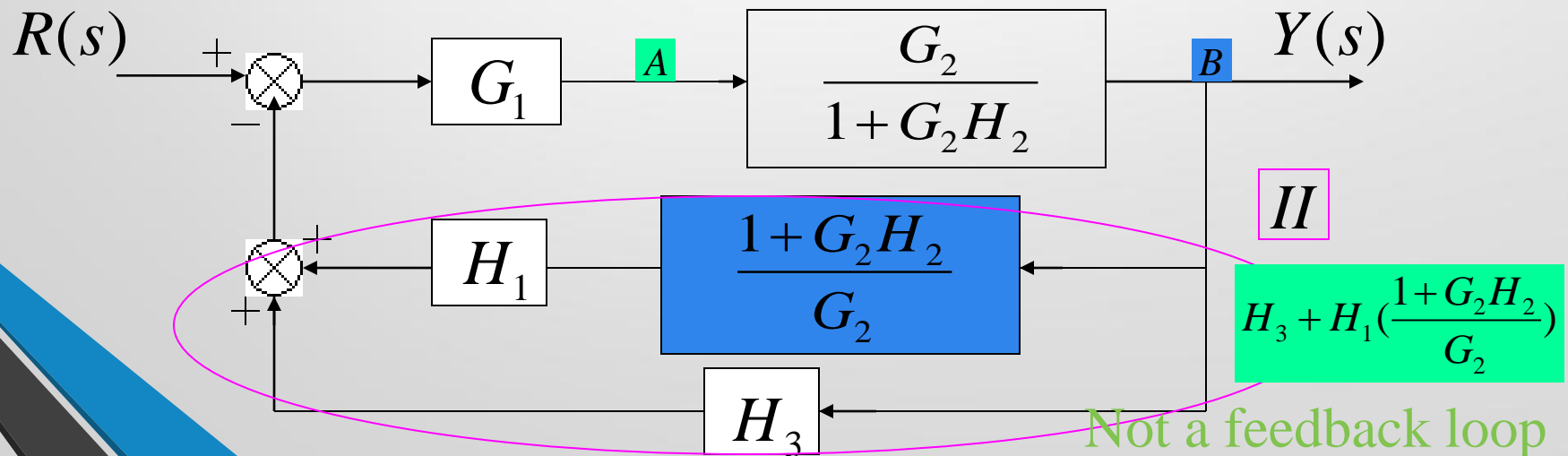

3. Eliminate loop II

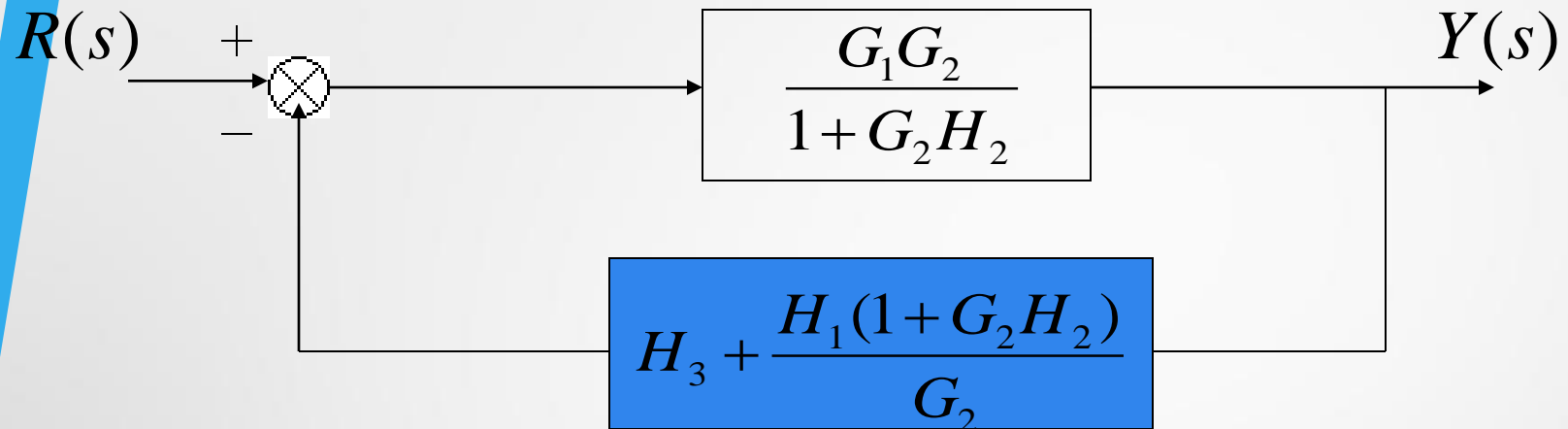

↓ Using rule 6

$$T(s) = \frac{Y(s)}{R(s)} = \frac{G_1 G_2}{1 + G_2 H_2 + G_1 G_2 H_3 + G_1 H_1 + G_1 G_2 H_1 H_2}$$

(c)

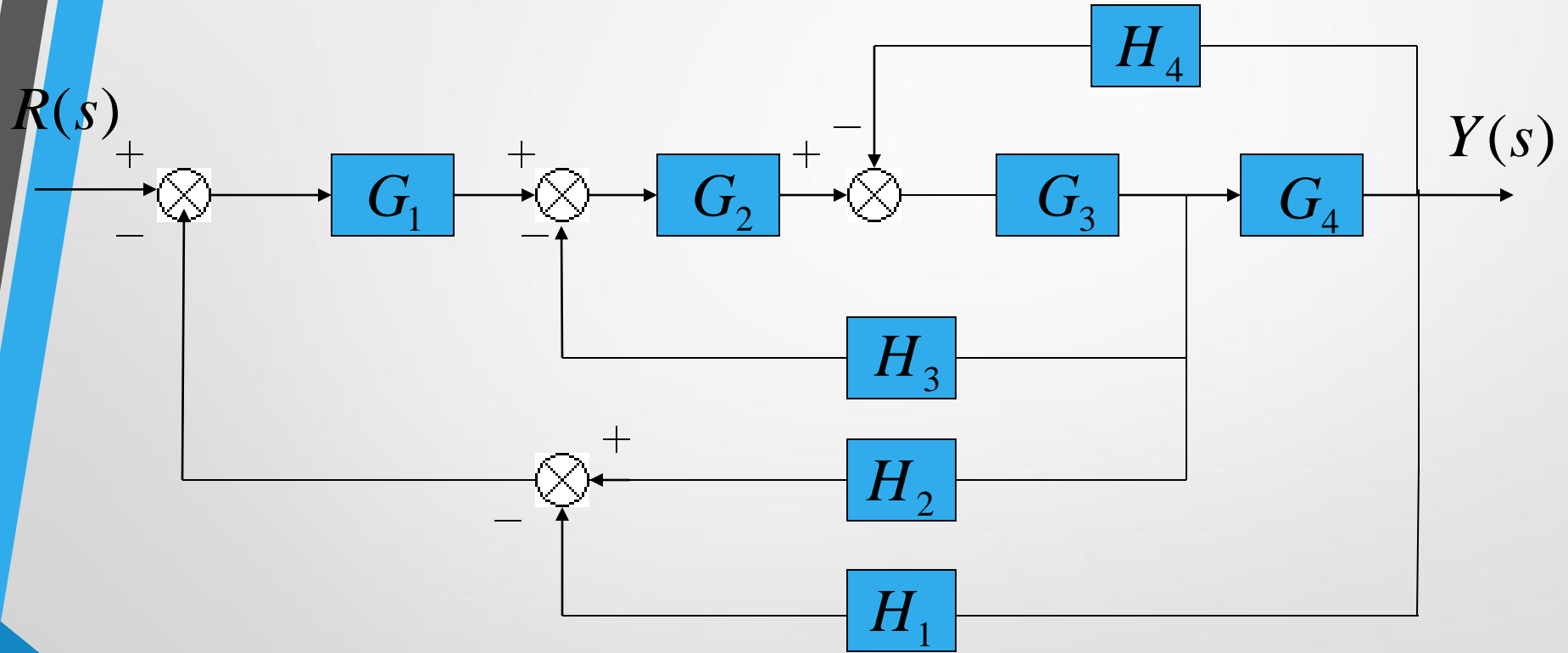

Solution:

1. Moving pickoff point A behind block G_4

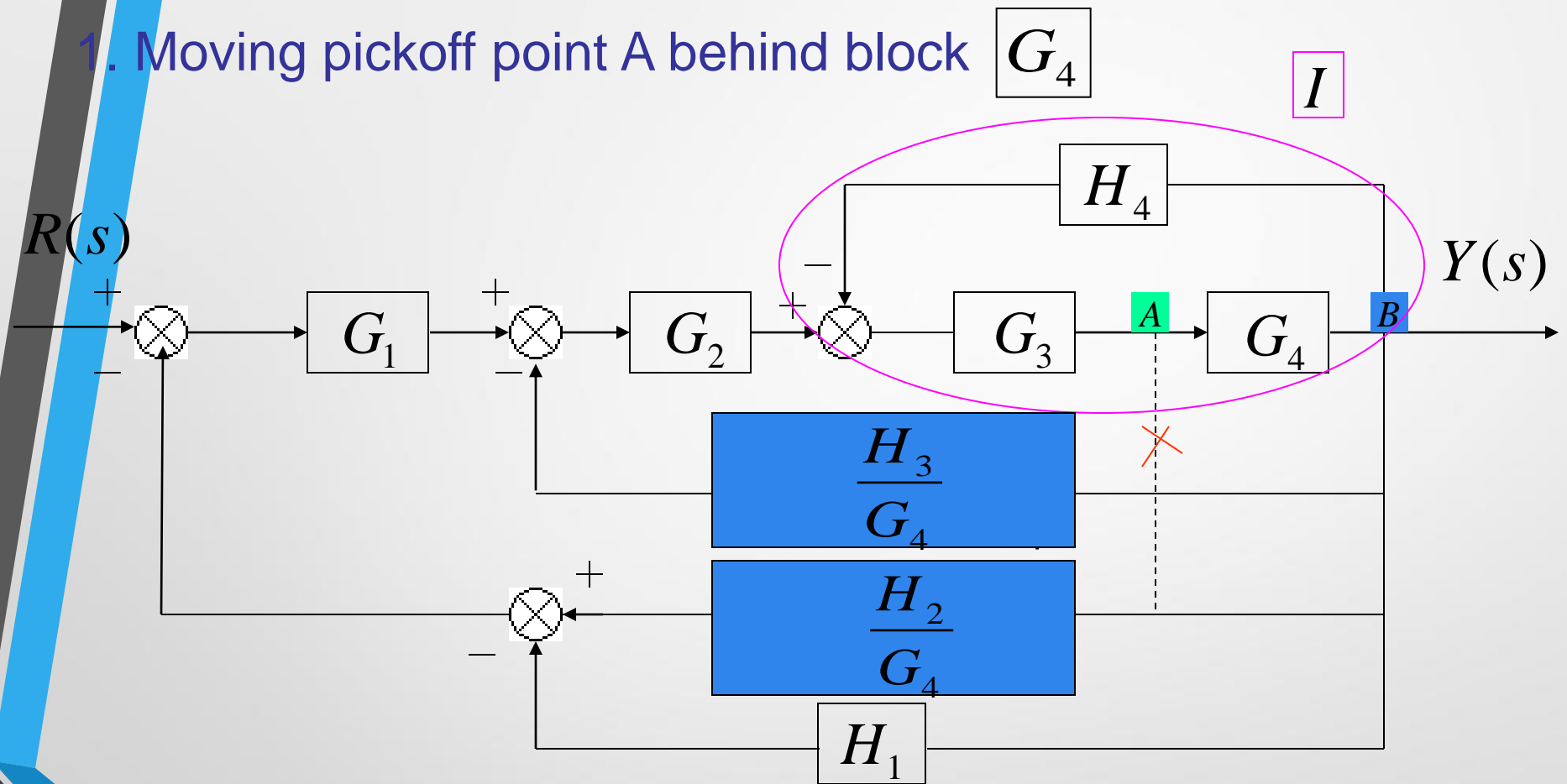

2. Eliminate loop I and Simplify

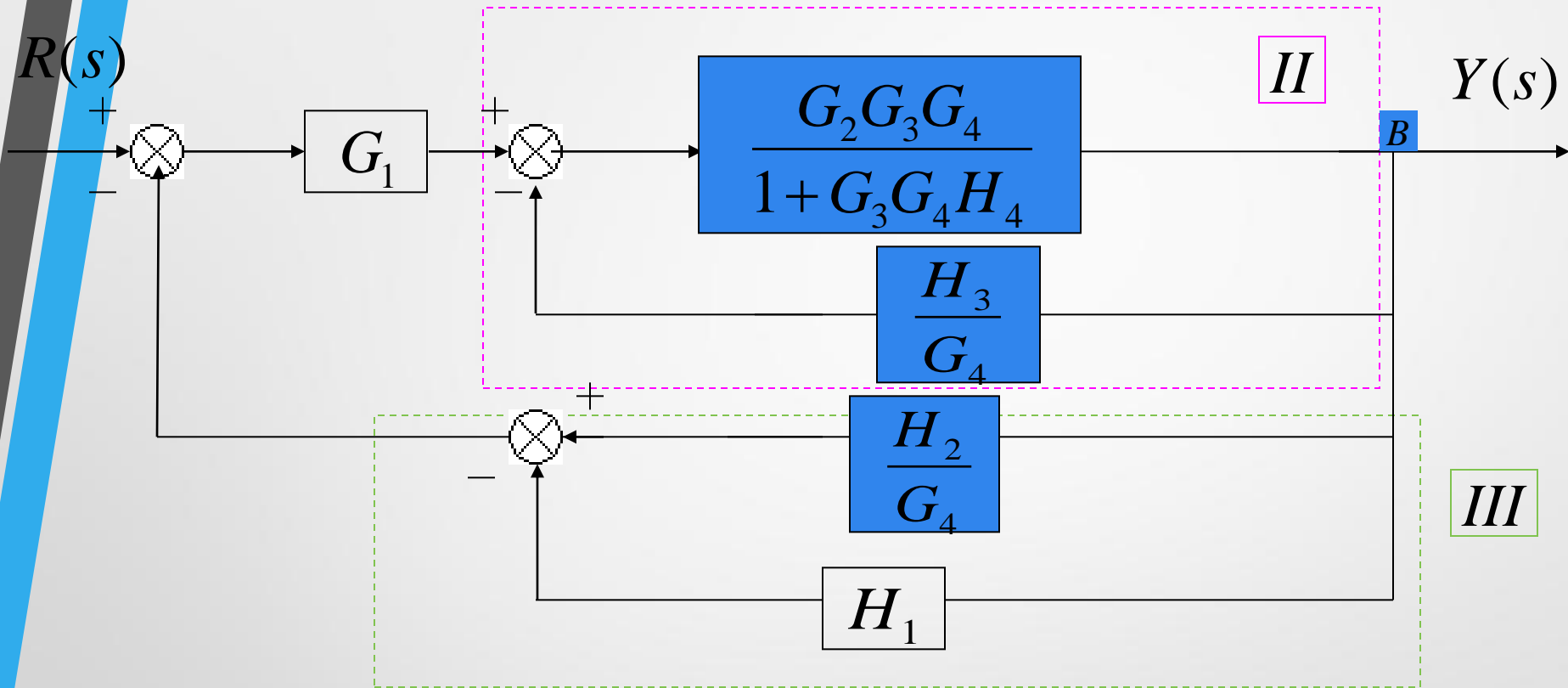

II  feedback

$$\frac{G_2 G_3 G_4}{1 + G_3 G_4 H_4 + G_2 G_3 H_3}$$

III  Not feedback

$$\frac{H_2 - G_4 H_1}{G_4}$$

3. Eliminate loop II & III

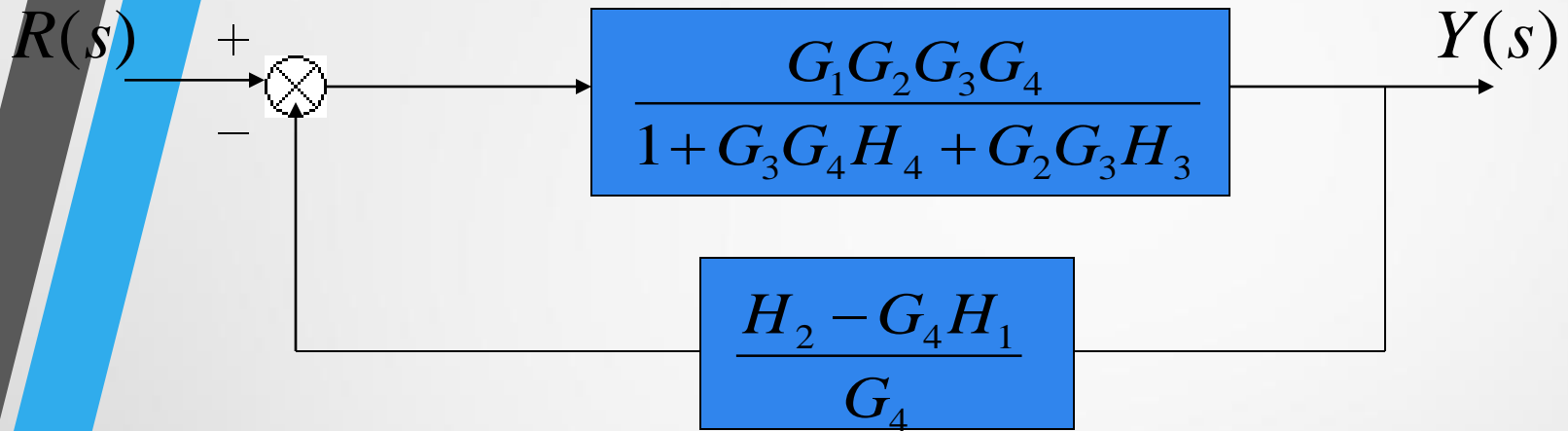

↓ Using rule 6

$$T(s) = \frac{Y(s)}{R(s)} = \frac{G_1 G_2 G_3 G_4}{1 + G_2 G_3 H_3 + G_3 G_4 H_4 + G_1 G_2 G_3 H_2 - G_1 G_2 G_3 G_4 H_1}$$

(d)

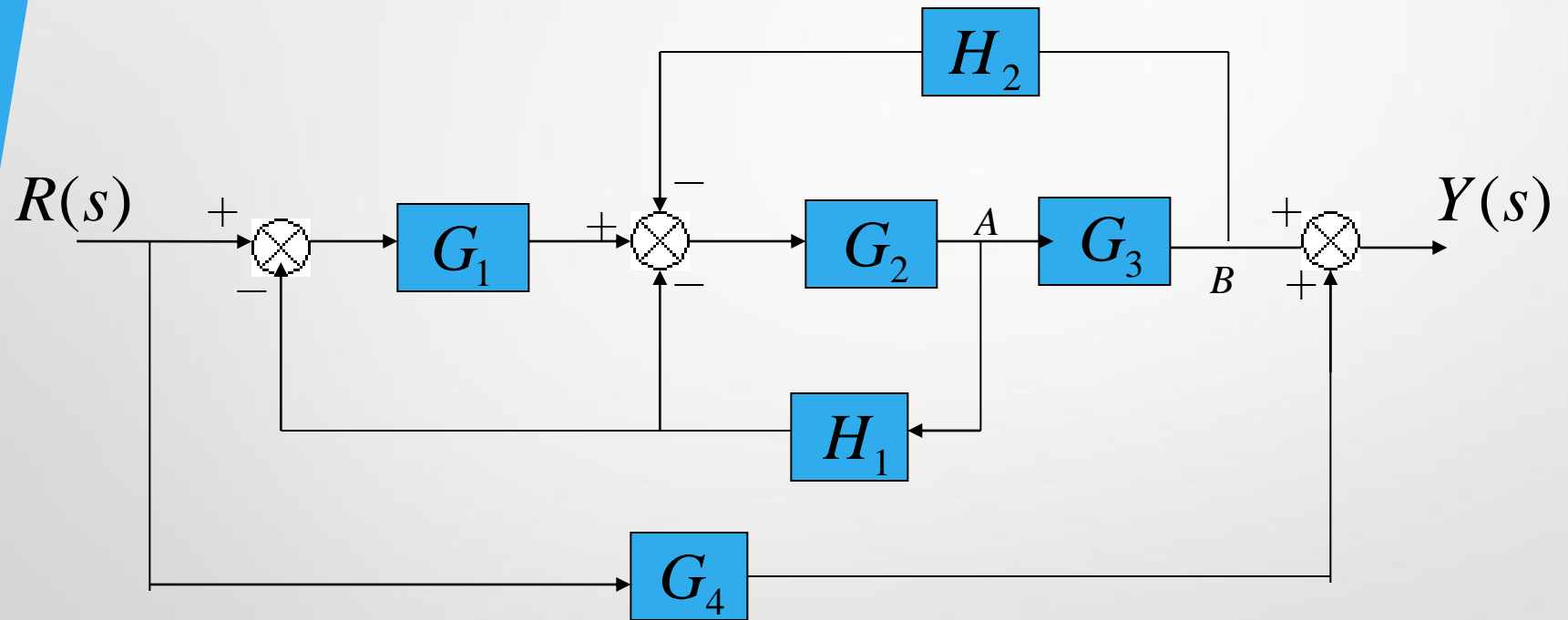

Solution:

1. Moving pickoff point A behind block G_3 I

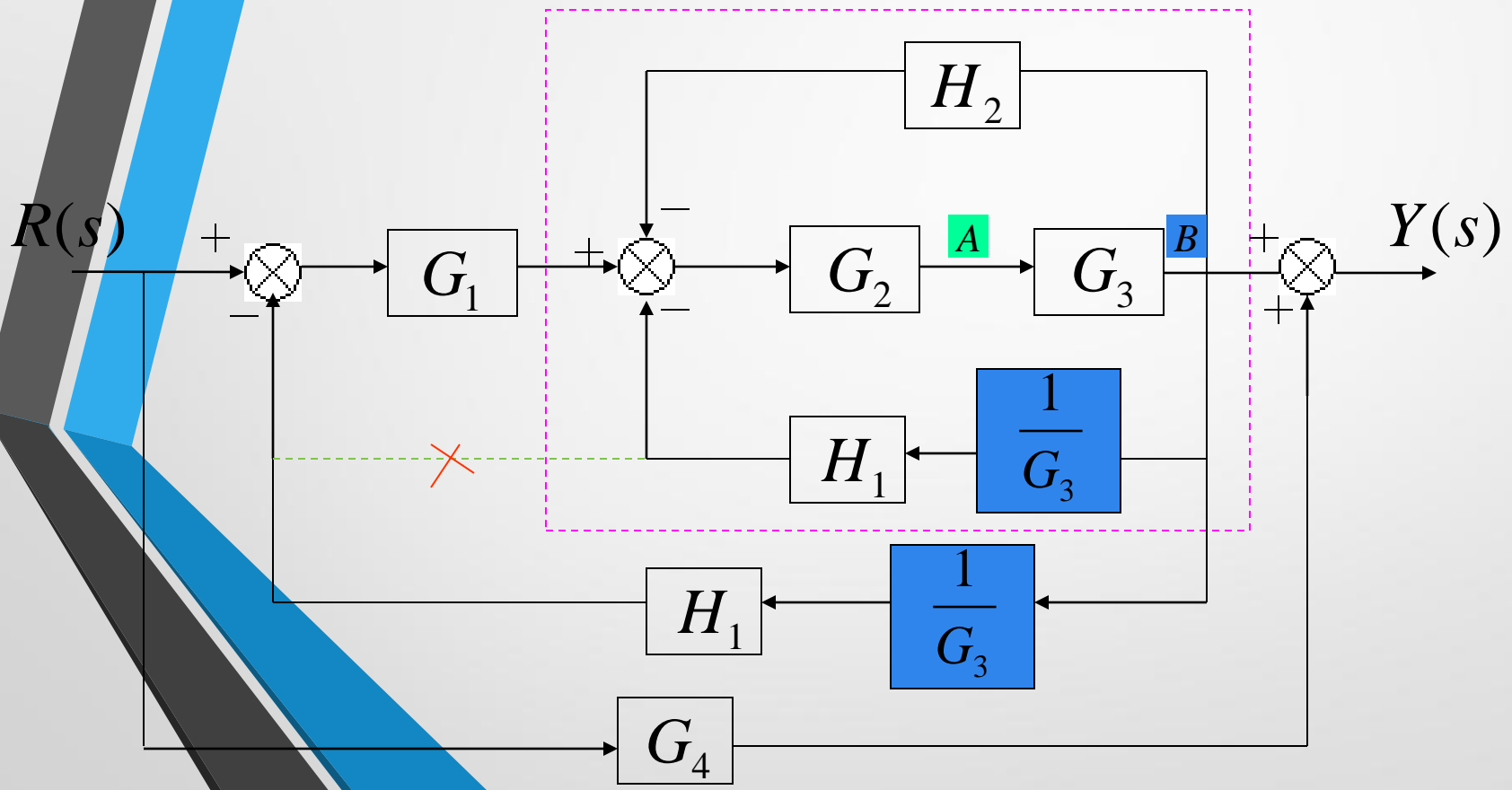

2. Eliminate loop I & Simplify

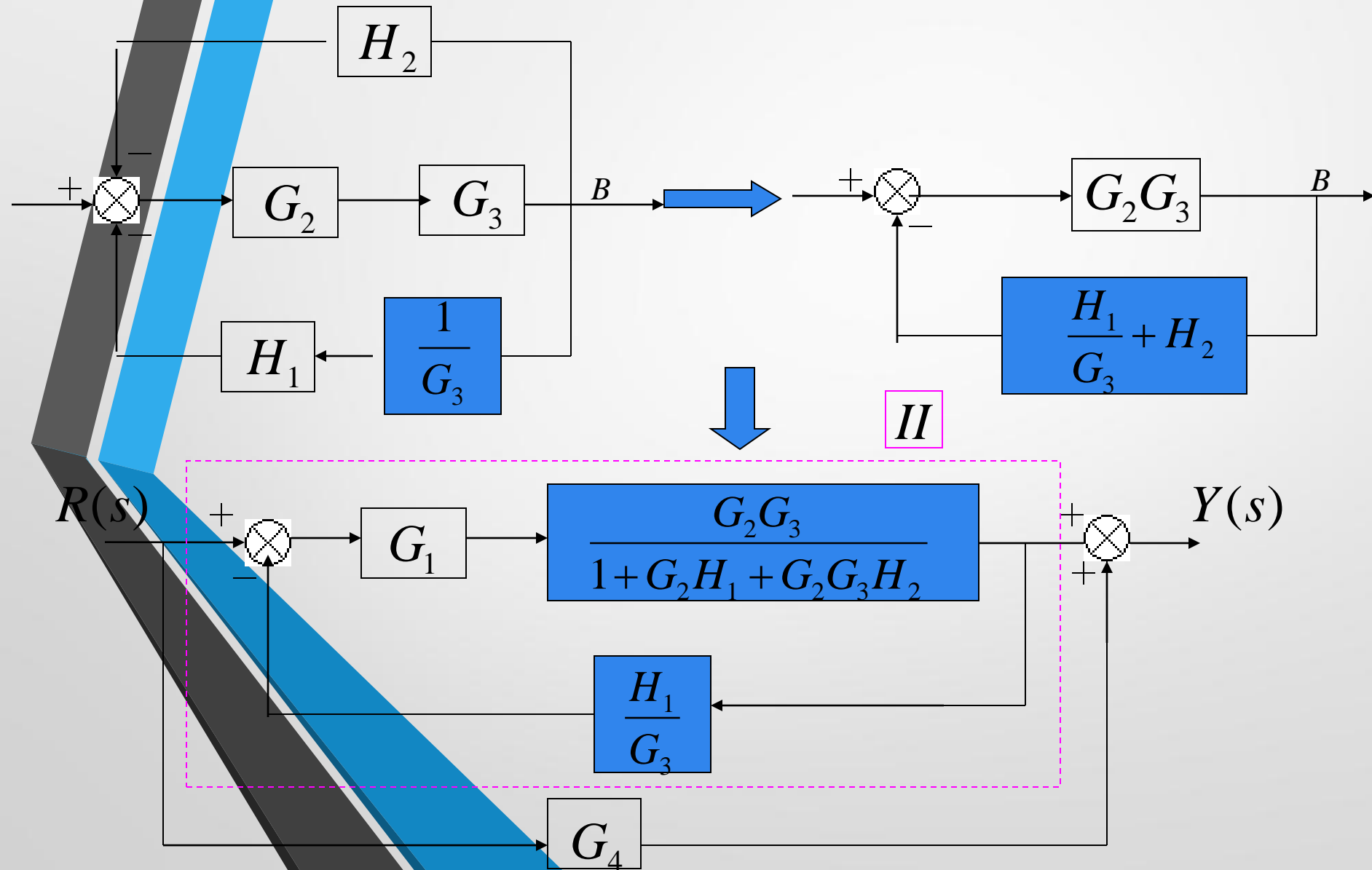

3. Eliminate loop II

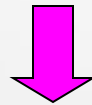
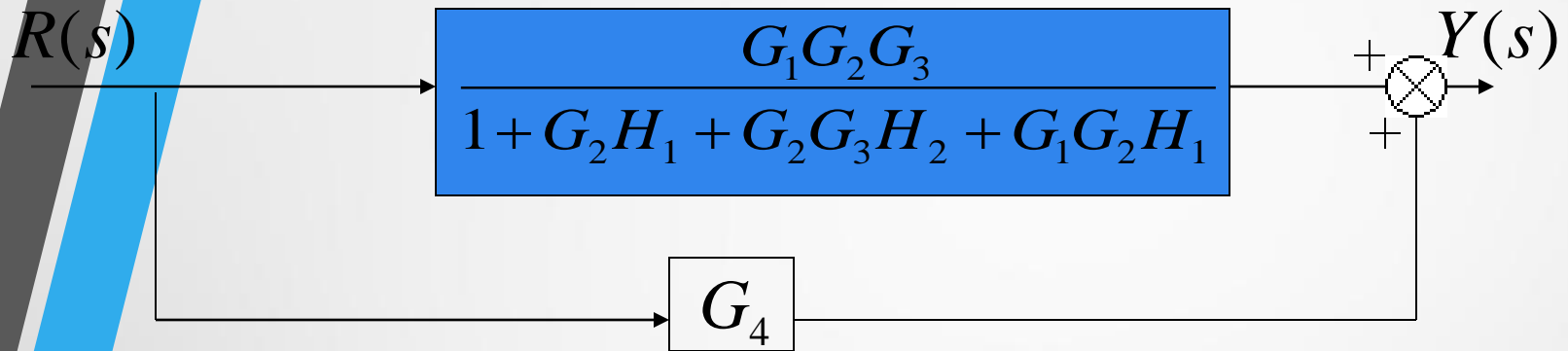

$$T(s) = \frac{Y(s)}{R(s)} = G_4 + \frac{G_1 G_2 G_3}{1 + G_2 H_1 + G_2 G_3 H_2 + G_1 G_2 H_1}$$

Example 2

Determine the effect of R and N on Y in the following diagram

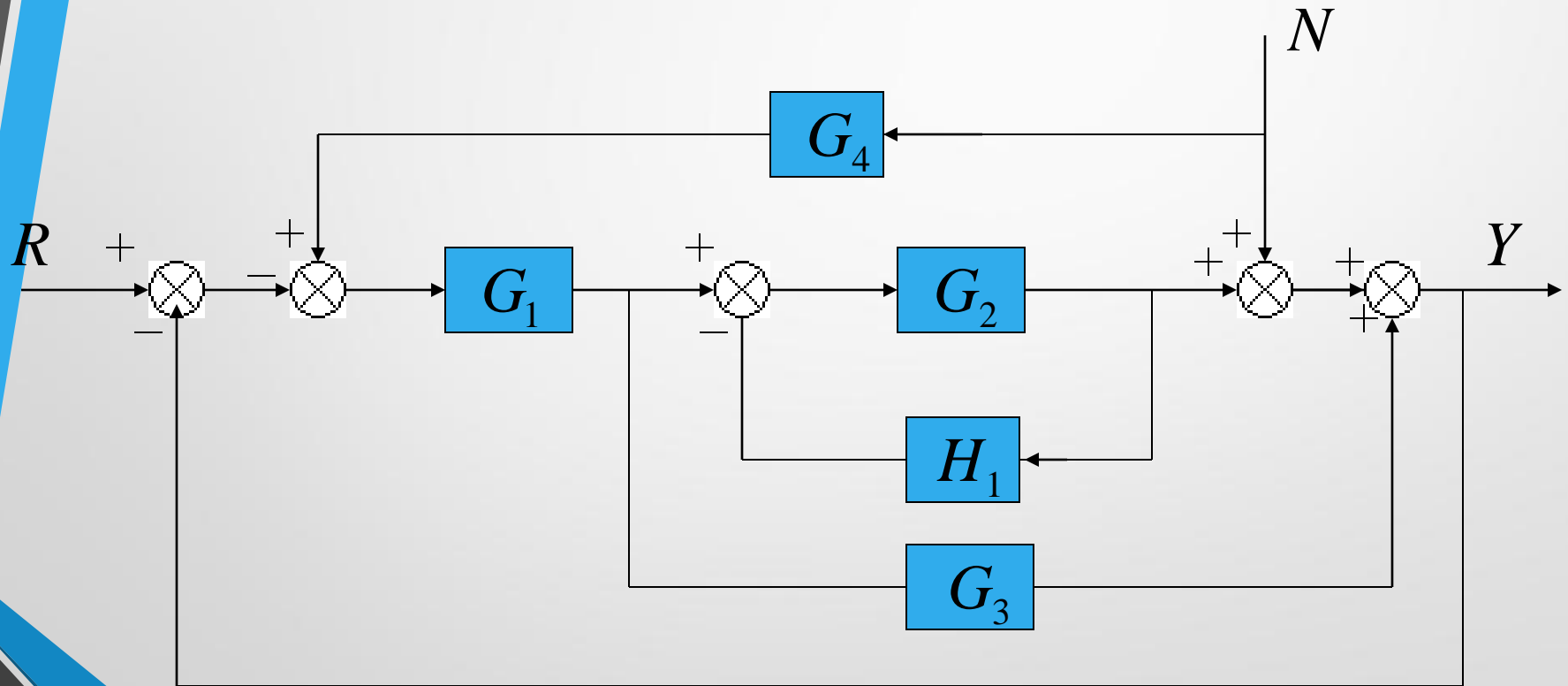

In this linear system, the output Y contains two parts, one part is related to R and the other is caused by N :

$$Y = Y_1 + Y_2 = T_1 R + T_2 N$$

If we set $N=0$, then we can get Y_1 :

$$Y_1 = Y_{N=0} = T_1 R$$

The same, we set $R=0$ and Y_2 is also obtained:

$$Y_2 = Y_{R=0} = T_2 N$$

Thus, the output Y is given as follows:

$$Y = Y_1 + Y_2 = Y_{N=0} + Y_{R=0}$$

Solution:

1. Swap the summing points A and B

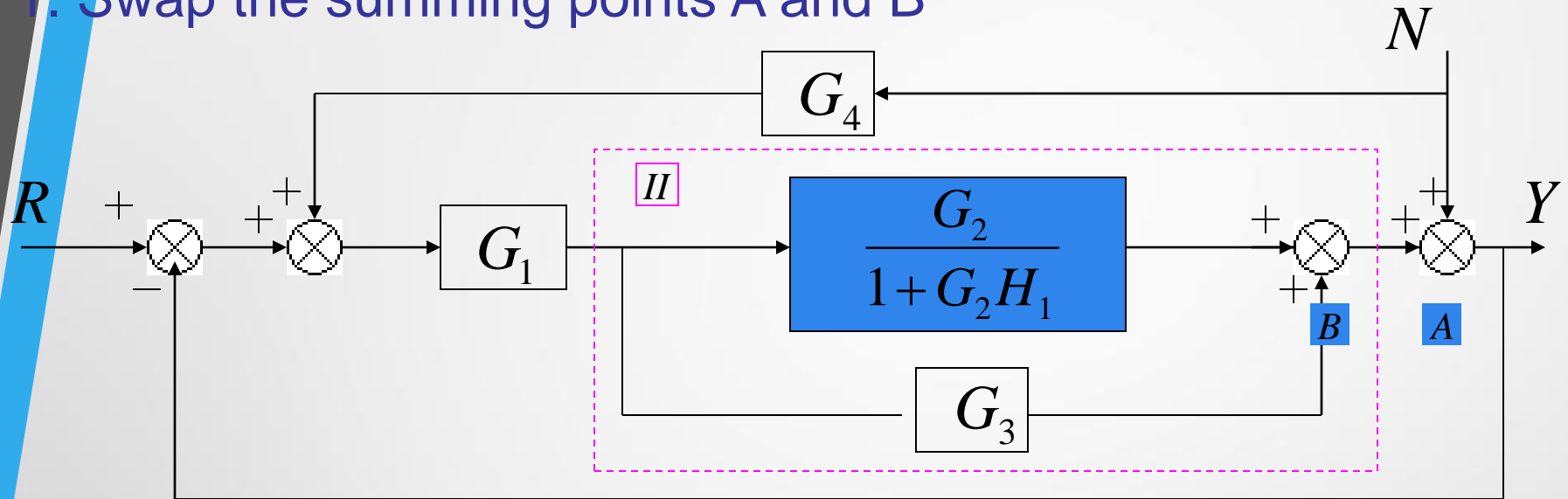

2. Eliminate loop II & simplify

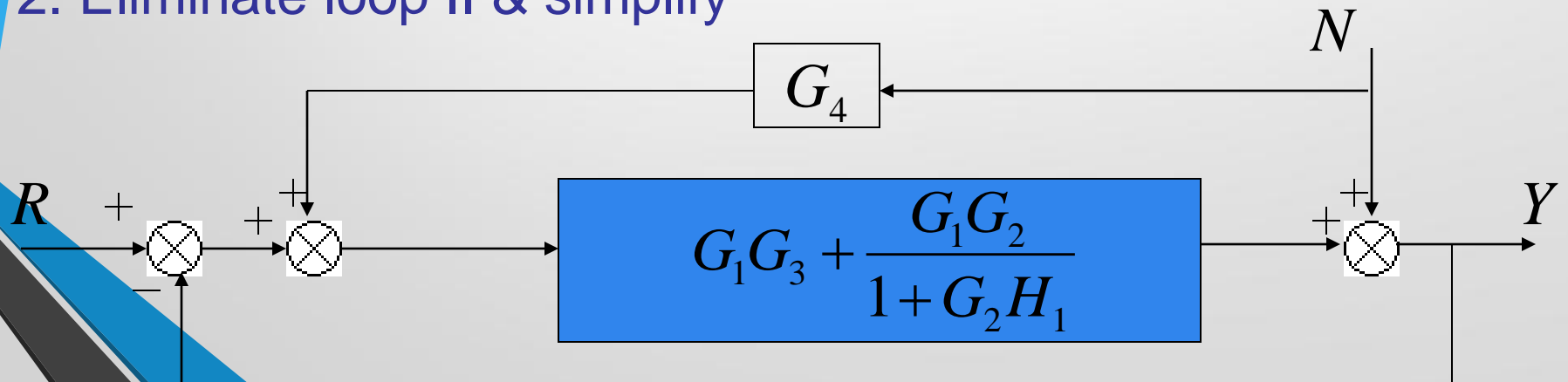

Rewrite the diagram:

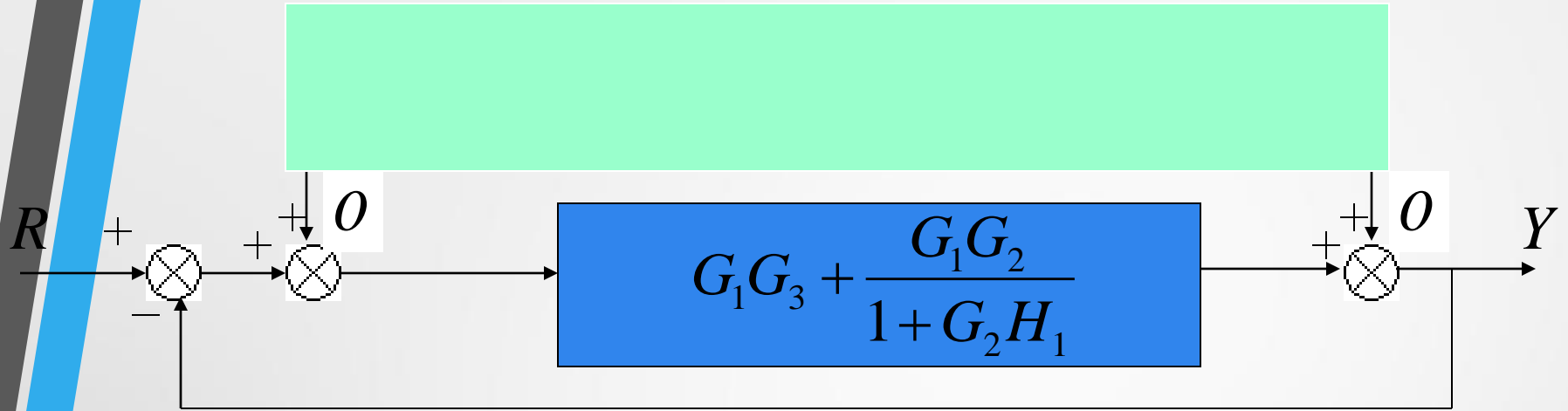

3. Let $N=0$

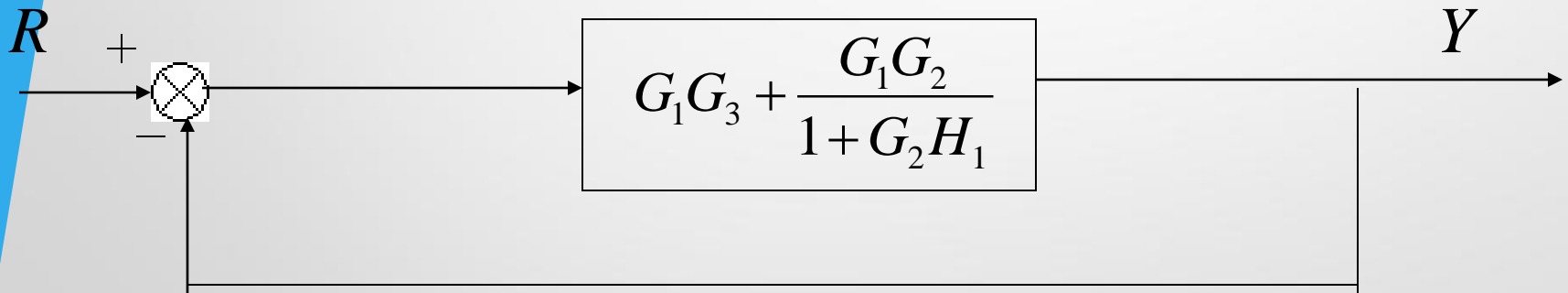

We can easily get Y_1

$$Y_1 = \frac{G_1G_2 + G_1G_3 + G_1G_2G_3H_1}{1 + G_2H_1 + G_1G_2 + G_1G_3 + G_1G_2G_3H_1} R$$

4. Let $R=0$, we can get:

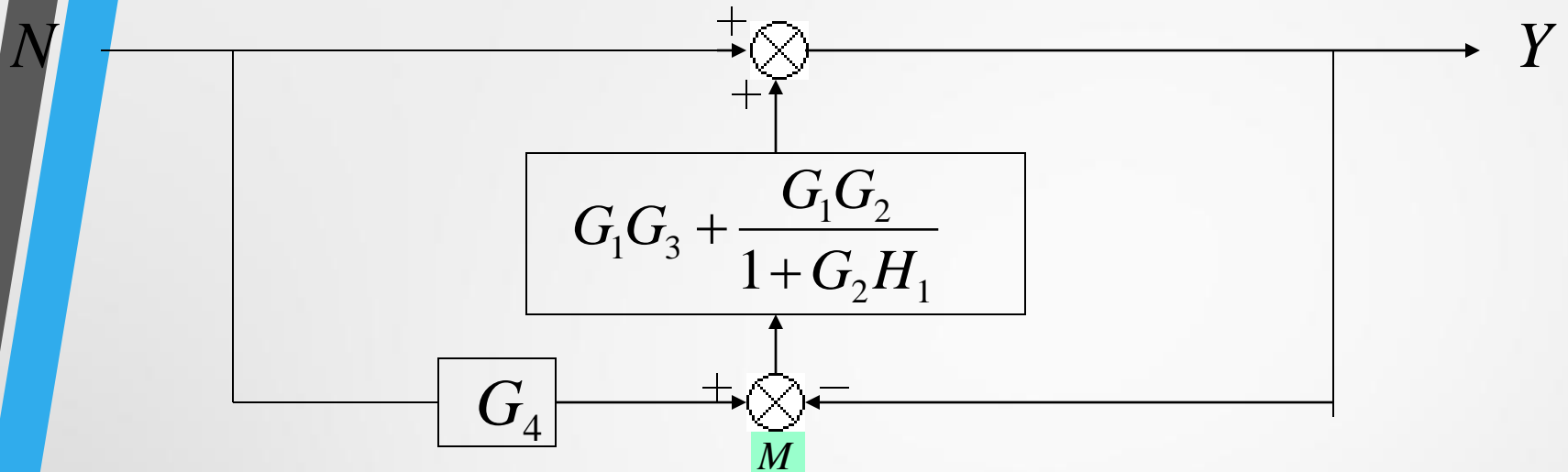

5. Break down the summing point M:

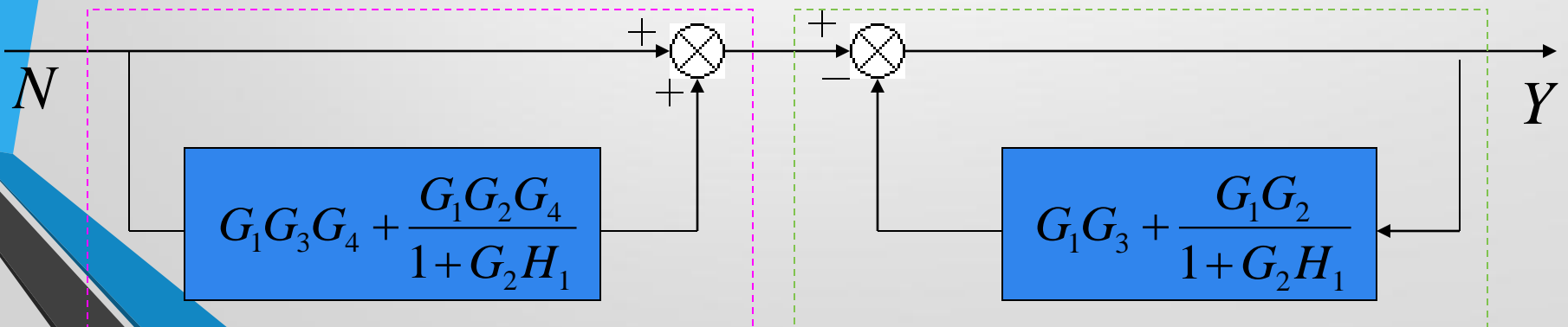

6. Eliminate above loops:

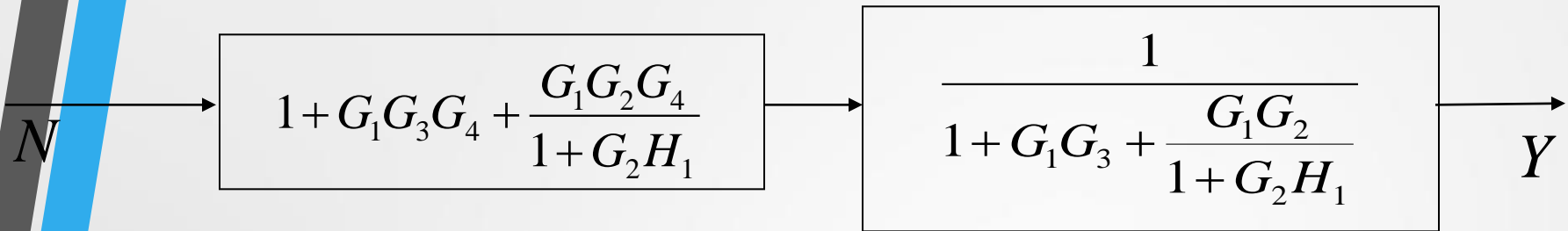

$$Y_2 = \frac{1 + G_2H_1 + G_1G_2G_4 + G_1G_3G_4 + G_1G_2G_3G_4H_1}{1 + G_2H_1 + G_1G_2 + G_1G_3 + G_1G_2G_3H_1} N$$

7. According to the principle of superposition, Y_1 and Y_2 can be combined together, So:

$$Y = Y_1 + Y_2$$

$$= \frac{1}{1 + G_2H_1 + G_1G_2 + G_1G_3 + G_1G_2G_3H_1} [(G_1G_2 + G_1G_3 + G_1G_2G_3H_1)R + (1 + G_2H_1 + G_1G_2G_4 + G_1G_3G_4 + G_1G_2G_3G_4H_1)N]$$