

Lecture 26

Op- Amp

Op-Amp Differentiator

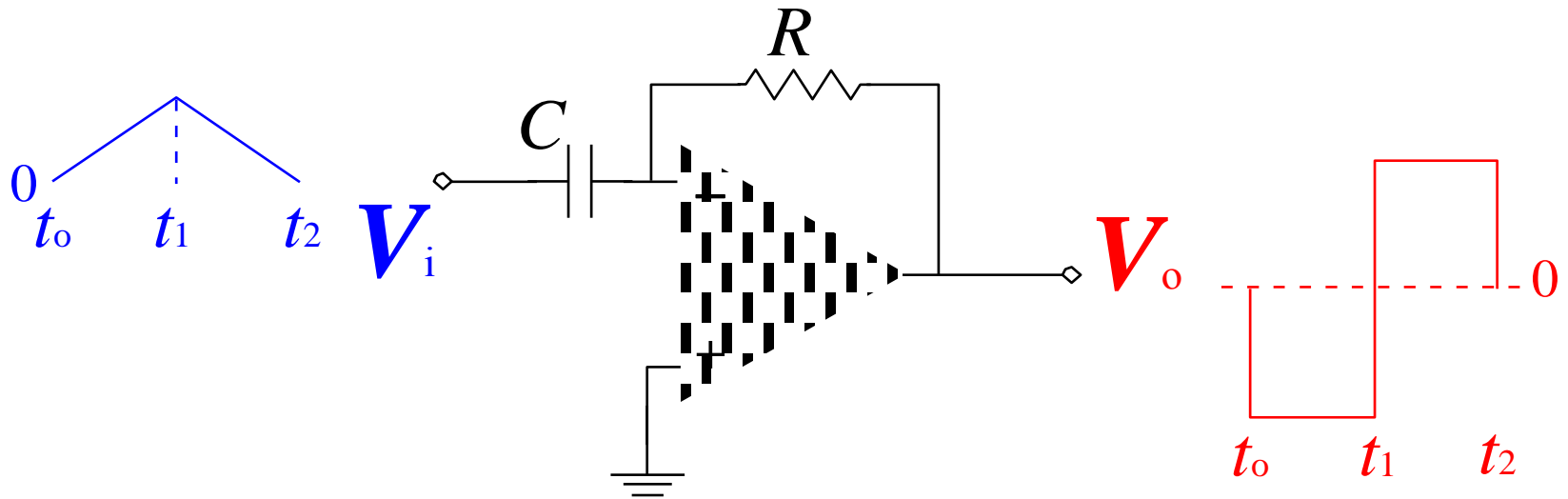

$$v_o = -\left(\frac{dV_i}{dt}\right)RC$$

Non-ideal case (Inverting Amplifier)

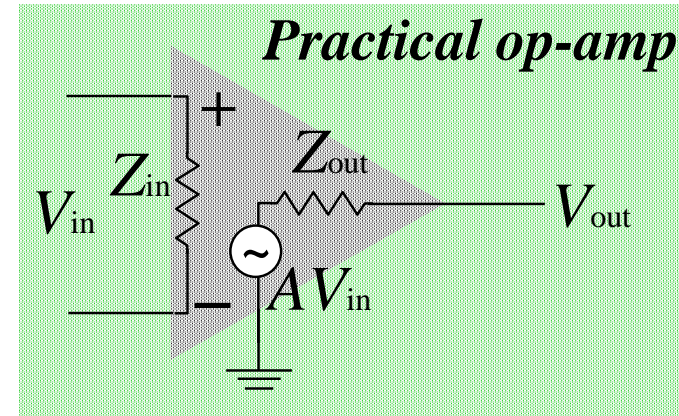
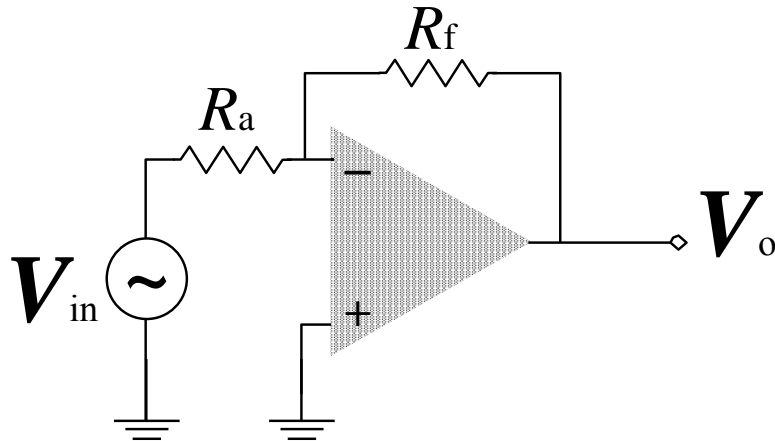

⇓ Equivalent Circuit

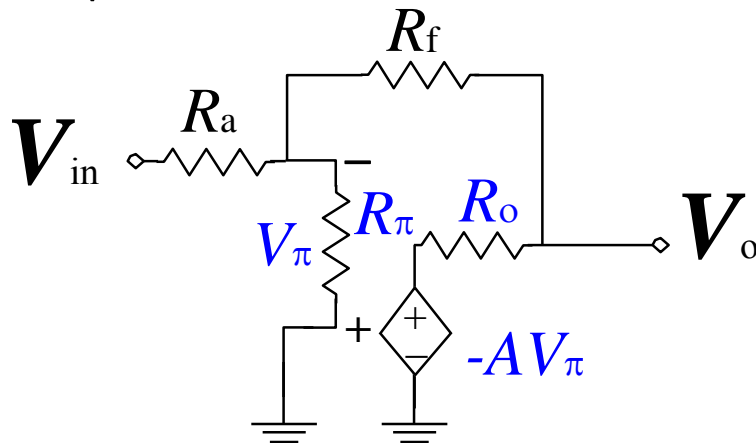

3 categories are considering

- Close-Loop Voltage Gain
- Input impedance
- Output impedance

Close-Loop Gain

Applied KCL at V- terminal,

$$\frac{V_{in} - V_{\pi}}{R_a} + \frac{-V_{\pi}}{R_{\pi}} + \frac{V_o - V_{\pi}}{R_f} = 0$$

By using the open loop gain,

$$V_o = -AV_{\pi}$$

$$\Rightarrow \frac{V_{in}}{R_a} + \frac{V_o}{AR_a} + \frac{V_o}{AR_{\pi}} + \frac{V_o}{R_f} + \frac{V_o}{AR_f} = 0$$

$$\Rightarrow \frac{V_{in}}{R_a} = -V_o \frac{R_{\pi}R_f + R_aR_f + R_aR_{\pi} + AR_aR_{\pi}}{AR_aR_{\pi}R_f}$$

The Close-Loop Gain, A_v

$$A_v = \frac{V_o}{V_{in}} = \frac{-AR_{\pi}R_f}{R_{\pi}R_f + R_aR_f + R_aR_{\pi} + AR_aR_{\pi}}$$

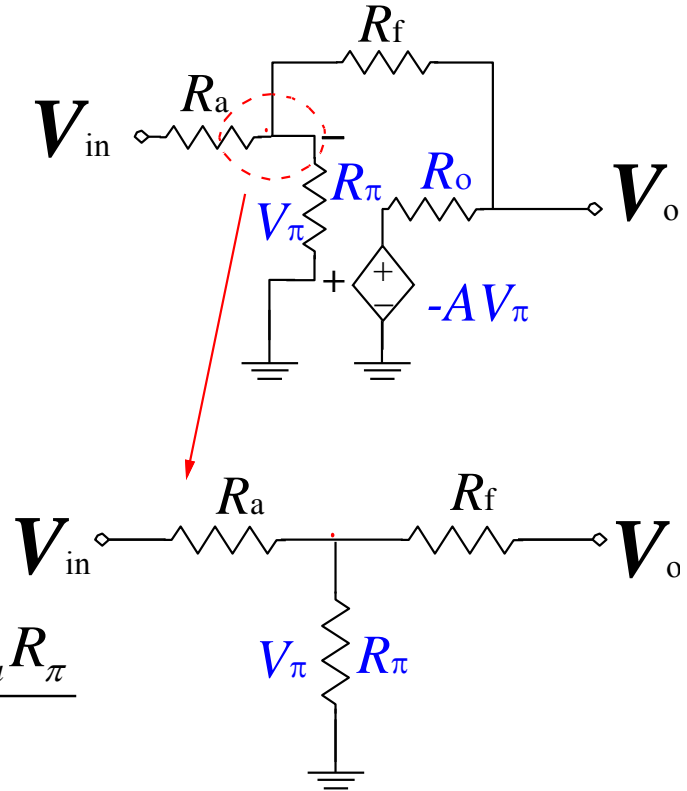

Close-Loop Gain

When the open loop gain is very large, the above equation become,

$$A_v \sim \frac{-R_f}{R_a}$$

Note : The close-loop gain now reduce to the same form as an ideal case

Input Impedance

Input Impedance can be regarded as,

$$R_{in} = R_a + R_\pi // R'$$

where R' is the equivalent impedance of the red box circuit, that is

$$R' = \frac{V_\pi}{i_f}$$

However, with the below circuit,

$$V_\pi - (-AV_\pi) = i_f (R_f + R_o)$$

$$\Rightarrow R' = \frac{V_\pi}{i_f} = \frac{R_f + R_o}{1 + A}$$

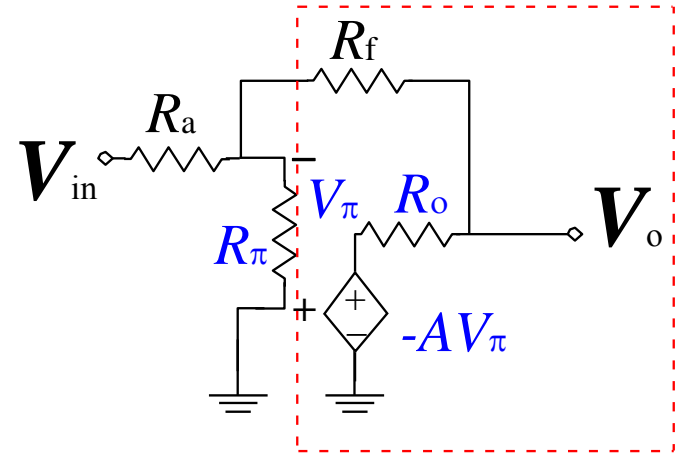

R'

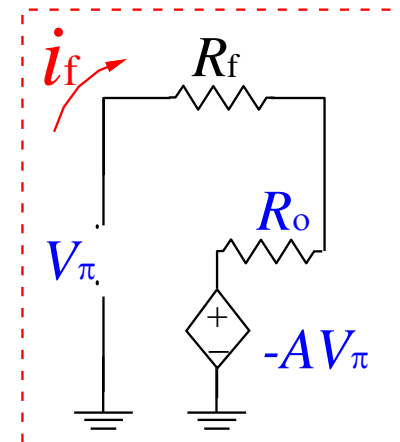

Input Impedance

Finally, we find the input impedance as,

$$R_{in} = R_a + \left[\frac{1}{R_\pi} + \frac{1+A}{R_f + R_o} \right]^{-1} \Rightarrow R_{in} = R_a + \frac{R_\pi (R_f + R_o)}{R_f + R_o + (1+A)R_\pi}$$

Since, $R_f + R_o \ll (1+A)R_\pi$, R_{in} become,

$$R_{in} \sim R_a + \frac{(R_f + R_o)}{(1+A)}$$

Again with $R_f + R_o \ll (1+A)$

$$R_{in} \sim R_a$$

Note: The op-amp can provide an impedance isolated from input to output

Output Impedance

Only source-free output impedance would be considered, i.e. V_i is assumed to be 0

Firstly, with figure (a),

$$V_\pi = \frac{R_a \parallel R_\pi}{R_f + R_a \parallel R_\pi} V_o \Rightarrow V_\pi = \frac{R_a R_\pi}{R_a R_f + R_a R_\pi + R_f R_\pi} V_o$$

By using KCL, $i_o = i_1 + i_2$

$$i_o = \frac{V_o}{R_f + R_a \parallel R_f} + \frac{V_o - (-AV_\pi)}{R_o}$$

By substitute the equation from Fig. (a),

The output impedance, R_{out} is

$$\frac{V_o}{i_o} = \frac{R_o (R_a R_f + R_a R_\pi + R_f R_\pi)}{(1 + R_o)(R_a R_f + R_a R_\pi + R_f R_\pi) + (1 + A)R_a R_\pi}$$

$\therefore R_\pi$ and A comparably large,

$$R_{out} \sim \frac{R_o (R_a + R_f)}{AR_a}$$

