

Lecture 22

BJT



Ch6 Basic BJT Amplifiers Circuits

6.2 Single-Stage BJT Amplifiers

Common-Base Amplifier

Ground the base and drive the input signal into the emitter

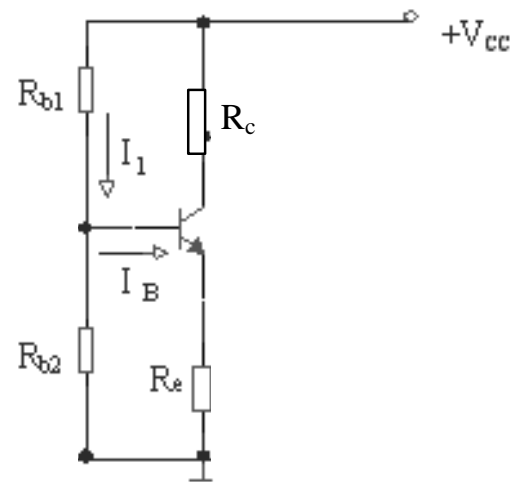
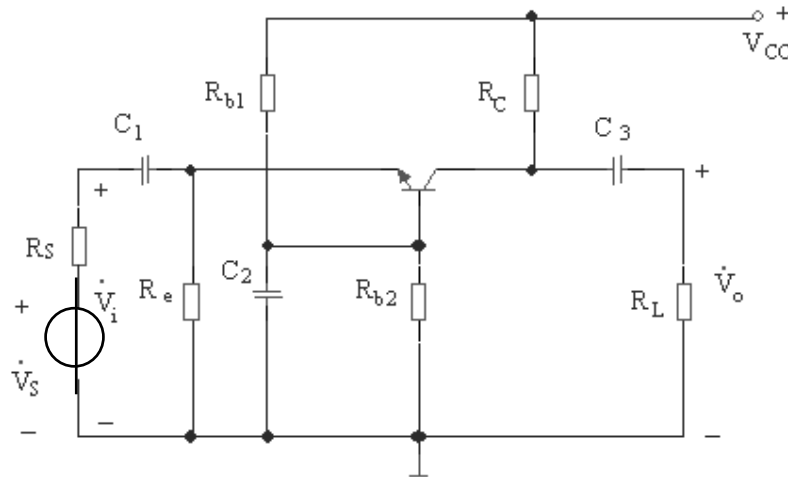

$$V_B - V_{BE} = I_E R_e \quad V_B = \frac{V_{CC}}{R_{b1} + R_{b2}} R_{b2}$$

$$I_C \approx I_E = \frac{V_B - V_{BE}}{R_e} \approx \frac{V_B}{R_e}$$

$$V_{CE} = V_{CC} - I_C R_C - I_E R_e \approx V_{CC} - I_C (R_C + R_e)$$

$$I_B = \frac{I_C}{\beta}$$



Ch6 Basic BJT Amplifiers Circuits

6.2 Single-Stage BJT Amplifiers

Common-Base Amplifier

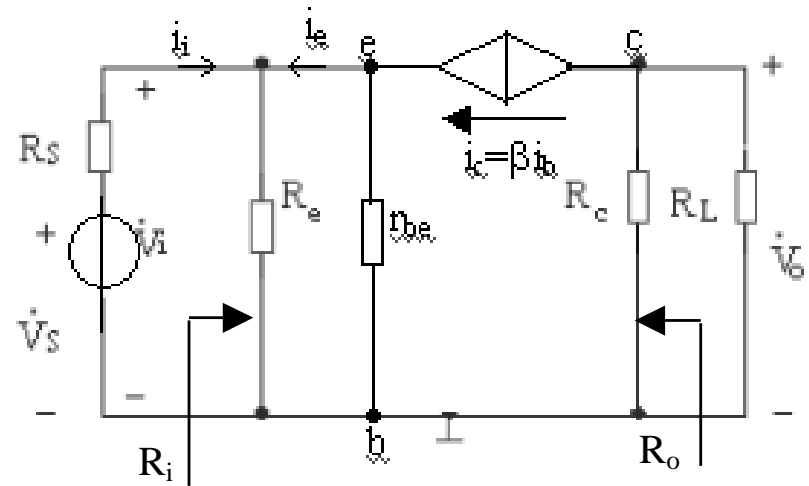
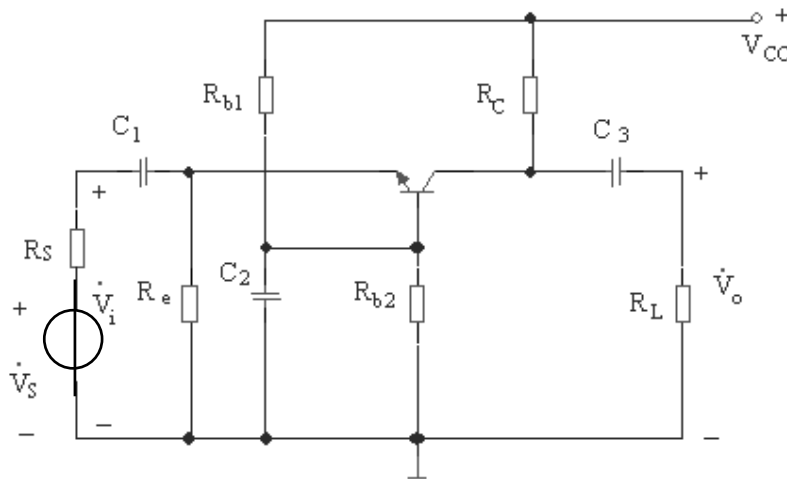

$$\rightarrow A_v = \frac{-i_c(R_C // R_L)}{-i_b r_{be}} = \frac{\beta(R_C // R_L)}{r_{be}}$$

$$R_i = \frac{r_{be}}{(1 + \beta)} // R_e$$

$$R_o \approx R_C$$

$$\dot{A}_i = \frac{\dot{I}_o}{\dot{I}_i} = \frac{-\beta R_C / (R_C + R_L)}{-\frac{r_{be}}{(1 + \beta)} // R_e} \approx \frac{\beta R_C / (R_C + R_L)}{(1 + \beta)} \cong \frac{I_E}{I_C} \approx 1$$

$$\text{For } R_L \ll R_C, A_i \approx \frac{\beta}{(1 + \beta)} \approx 1 (\text{since } I_E \cong I_C)$$



Ch6 Basic BJT Amplifiers Circuits

6.2 Single-Stage BJT Amplifiers

Common-Base Amplifier

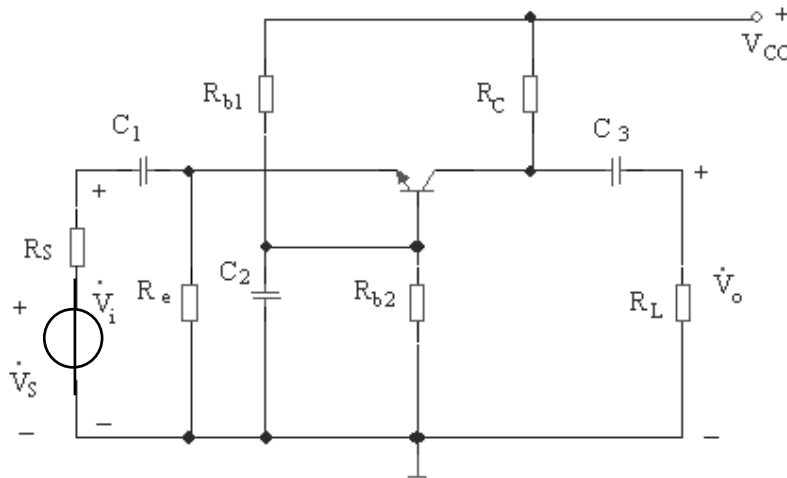

$$\dot{A}_i = \frac{\dot{I}_o}{\dot{I}_i} \approx \frac{\beta R_C / (R_C + R_L)}{(1 + \beta)} \approx \frac{R_C}{R_C + R_L}$$

$$\text{For } R_L \ll R_C \quad A_i \approx \frac{\beta}{(1 + \beta)} \approx 1$$

$$A_v = \frac{\beta(R_C \parallel R_L)}{r_{be}}$$

$$R_i = \frac{r_{be}}{(1 + \beta)} \parallel R_e \approx \frac{r_{be}}{(1 + \beta)}$$

$$R_o \approx R_C$$

CB amp characteristics:

- current gain has little dependence on β
- is non-inverting
- most commonly used as a unity-gain current amplifier or current buffer and not as a voltage amplifier: accepts an input signal current with low input resistance and delivers a nearly equal current with high output impedance
- most significant advantage is its excellent frequency response



Ch6 Basic BJT Amplifiers Circuits

Summary for three types of diodes:

	C-C	C-E	C-B
Input	I_B	I_B	I_B
Output	I_E	I_C	I_C
Functions	$Z_{out} < Z_{in}$ $V_{out} \approx V_{in}$	$Z_{out} > Z_{in}$ $V_{out} > V_{in}$	$Z_{out} > Z_{in}$ $V_{out} > V_{in}$