



# **ELECTRONICS DEVICES AND CIRCUITS**

## **SECTION - D**

### **SOME SPECIAL DEVICES**



**SCR**

# SCR

- A **silicon-controlled rectifier** (or **semiconductor-controlled rectifier**) is a four-layer solid state device that controls current.
- Silicon is chosen because of its high temperature and power capabilities.
- The basic operation of the SCR is different from that of an ordinary two-layer semiconductor diode in that a third terminal, called a gate, determines when the rectifier switches from on-state to off state.

# Construction of SCR

- It consists of a four layers pellet of P and N type semiconductor materials.
- Silicon is used as the intrinsic semiconductor to which the proper impurities are added.
- The junctions are either diffused or alloyed.

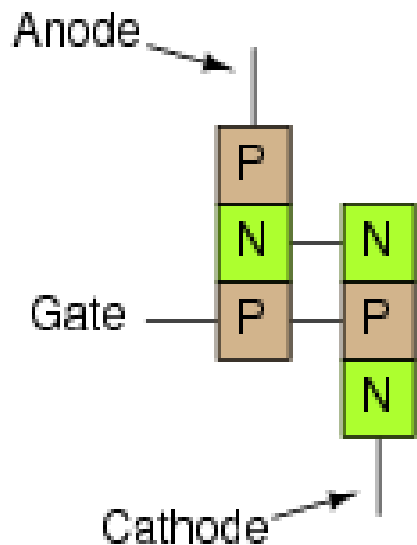

*Physical diagram*

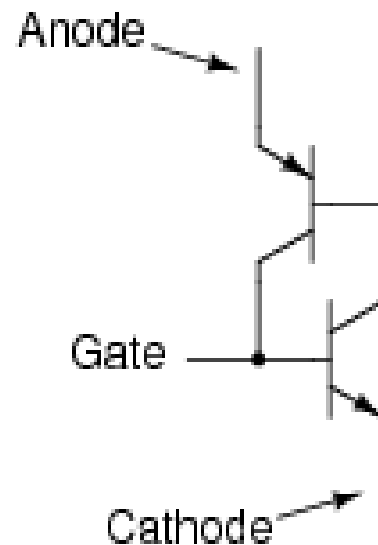

*Equivalent schematic*

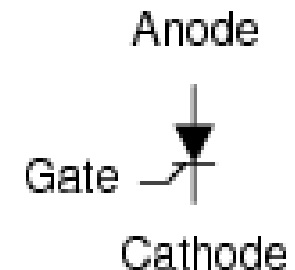

*Schematic symbol*

# Construction of SCR

- The Planar construction is used for **low power SCRs**, here all the junctions are diffused.
- The **Mesa type construction** is used for high power SCRs. In this case junction J2 is obtained by diffusion method and then the outer two layers are alloyed to it because the PNPN pellet is required to handle large currents.
- It is properly braced with tungsten or molybdenum plates to provide greater mechanical strength. One of these plates is hard soldered to a copper stud, which is threaded for attachment of heat sink. The doping of PNPN will depend on the application of SCR.

# Modes of operation

- In the normal "off" state, the device restricts current to the leakage current.
- When the gate-to-cathode voltage exceeds a certain threshold, the device turns "on" and conducts current.
- The device will remain in the "on" state even after gate current is removed so long as current through the device remains above the holding current.

## Conti...

- Once current falls below the holding current for an appropriate period of time, the device will switch **"off"**.
- If the gate is pulsed and the current through the device is below the holding current, the device will remain in the **"off"** state.

# Modes of operation

- If the applied voltage increases rapidly enough, **capacitive coupling** may induce enough charge into the gate to trigger the device into the "on" state; this is referred to as "dv/dt triggering."
- This is usually prevented by limiting the rate of voltage rise across the device, perhaps by using a **snubber**. "dv/dt triggering" may not switch the SCR into full conduction rapidly and the partially-triggered SCR may dissipate more power than is usual, possibly harming the device.



## Modes of operation

- SCRs can also be triggered by increasing the forward voltage beyond their rated **breakdown voltage** (also called as break over voltage), but again, this does not rapidly switch the entire device into conduction and so may be harmful so this mode of operation is also usually avoided.
- Also, the actual breakdown voltage may be substantially higher than the rated breakdown voltage, so the exact trigger point will vary from device to device.

# Modes of operation

- SCRs are used in power switching, phase control, chopper, battery chargers.
- Industrially they are applied to produce variable DC voltages for motors from AC line voltage.
- They control the bulk of the dimmers used in stage lighting, and can also be used in some electric vehicles to modulate the working voltage in a .

## Conti....

- Another common application is phase control circuits used with inductive loads.
- SCRs can also be found in welding power supplies where they are used to maintain a constant output current or voltage.
- Large silicon-controlled rectifier assemblies with many individual devices connected in series are used in high-voltage DC converter stations.

## Modes of operation

- Two SCRs in "inverse parallel" are often used in place of a TRIAC for switching inductive loads on AC circuits.
- Because each SCR only conducts for half of the power cycle and is reverse-biased for the other half-cycle, turn-off of the SCRs is assured.
- By comparison, the TRIAC is capable of conducting current in both directions and assuring that it switches "off" during the brief zero-crossing of current can be difficult.

# Modes of operation

- A switch (**S**) is used to apply or remove the input gate voltage which is obtained from a voltage source and resistor  $R_g$ .

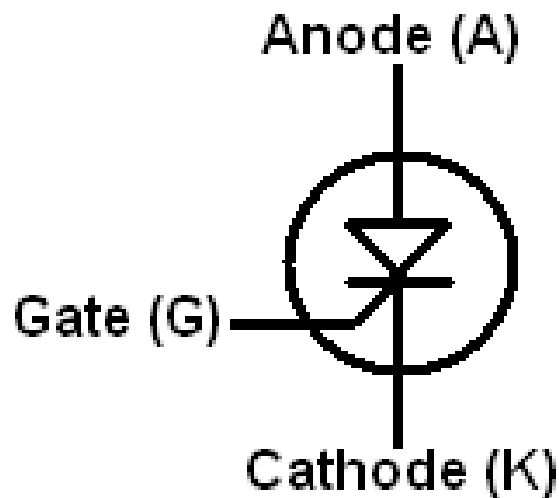
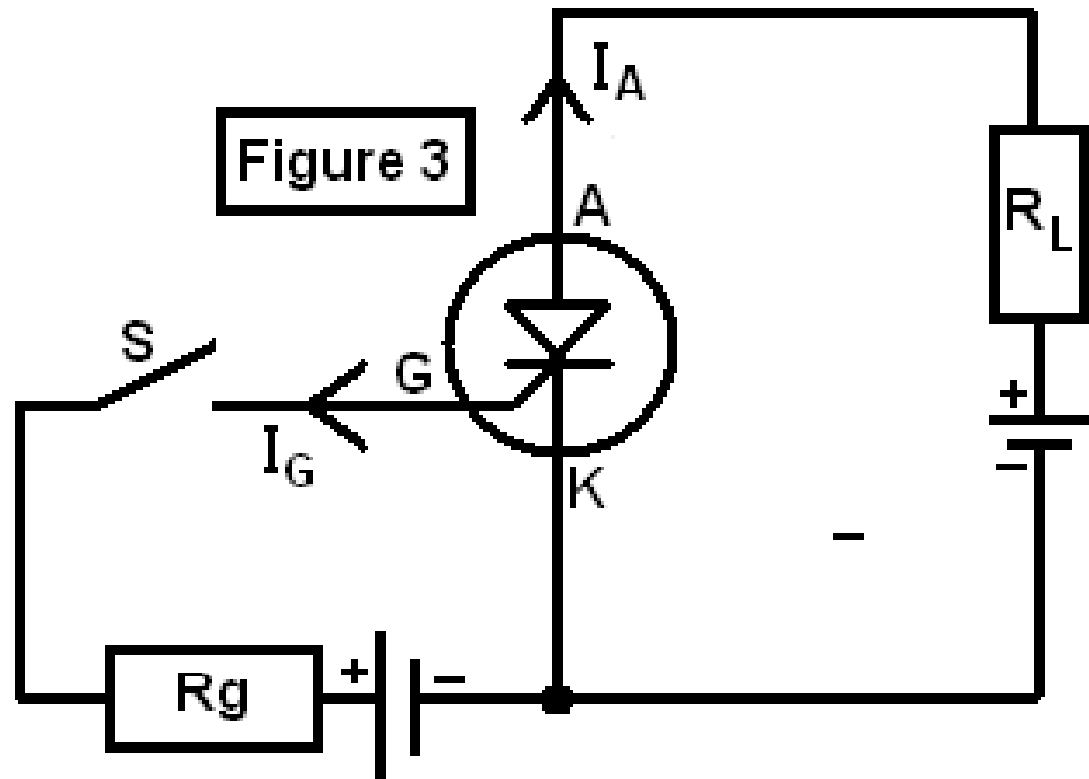

Figure 2



## Conti...

- This resistor is used to limit the gate current ( $I_G$ ) to a specific value.
- The SCR's **anode-to-cathode** voltage is provided by another voltage source and a series load resistor ( $R_L$ ) is also used to limit the SCR's cathode-to-anode current to a safe value when the device is turned on.
- Without this resistor, the SCR would conduct a very high cathode-to-anode current (also referred to as anode current or  $I_A$  ) and could be permanently damaged.

# I-V Characteristics of SCR

- The SCR is first biased in the forward direction while its gate is left open.
- The SCR's cathode-to-anode voltage is designated as  $V_F$  at this time.
- The curve shows that as  $V_F$  increases from zero, the SCR conducts only a small forward current ( $I_F$ ) which is due to leakage.
- As  $V_F$  continues to increase,  $I_F$  remains very low and almost constant but eventually a point is reached where  $I_F$  increases rapidly and  $V_F$  drops to a low value (note the horizontal dotted line).

# I-V Characteristics of SCR

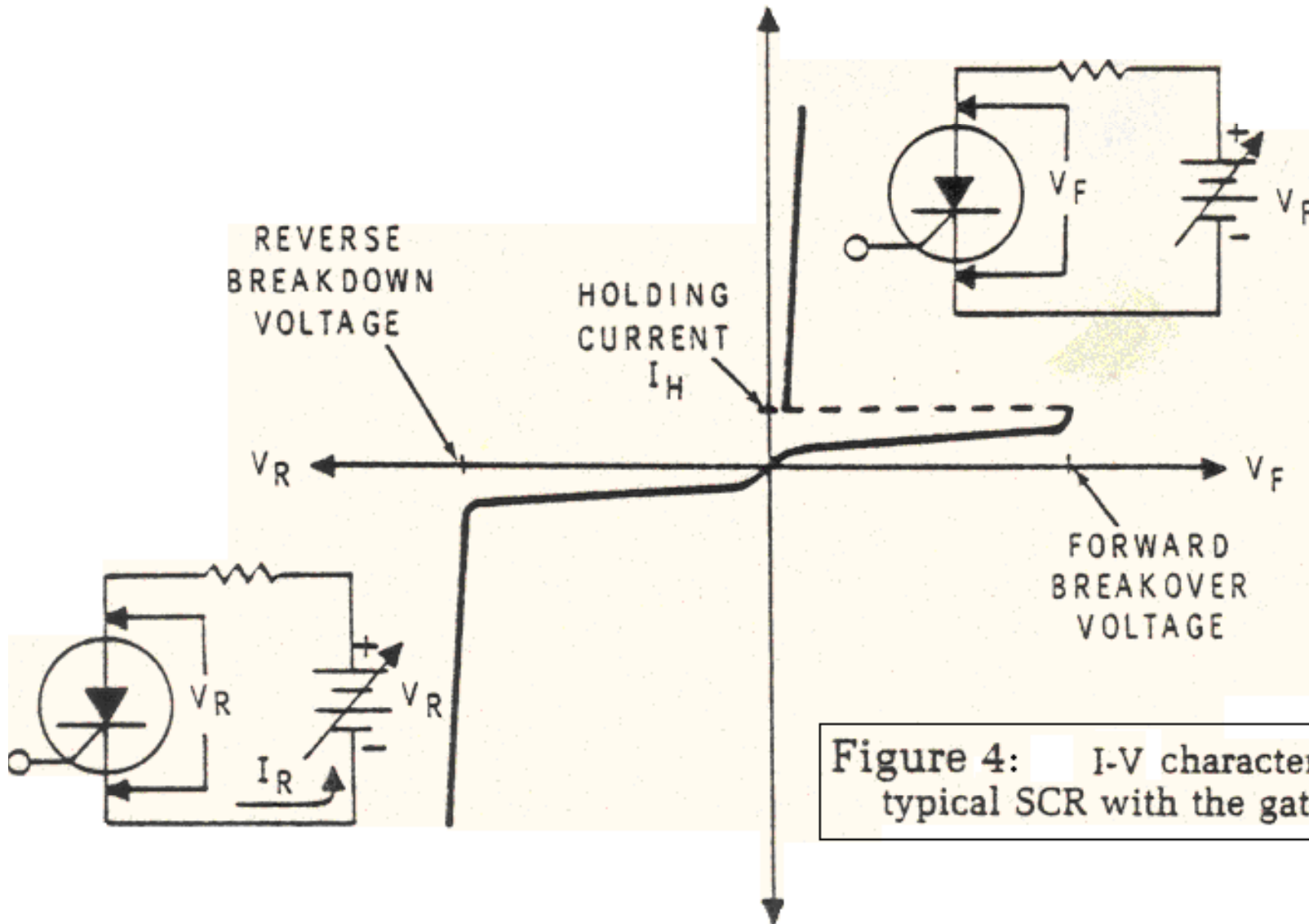

Figure 4: I-V characteristics of a typical SCR with the gate open.



# I-V Characteristics of SCR

- The VF value required to trigger this sudden change is referred to as the Forward Breakover Voltage ( $V_p$ ).
- When this value of  $V_p$  is reached the SCR simply breaks down, and conducts a high  $I_F$  which is limited only by the external resistance in series with the device.

# I-V Characteristics of SCR

- The SCR switches from the off state to the on state at this time. The drop in  $V_F$  occurs because the SCR's resistance drops to an extremely low value and most of the source voltage appears across the series resistor.
- When the SCR is in the on state, only a slight increase in  $V_F$  is required to produce a tremendous increase in  $I_F$  (the curve is almost vertical and straight).

# I-V Characteristics of SCR

- Furthermore, the SCR will remain in the on state as long as  $I_F$  remains at a substantial value.
- Only when  $I_F$  drops below a certain minimum value, will the SCR switch back to its off-state.
- This minimum value of  $I_F$  which will hold the SCR in the on state is referred to as the SCR's Holding Current and is usually designated at  $I_H$ .
- The  $I_H$  value is located at the point where breakover occurs (just to the left of the horizontal dotted line).

# I-V Characteristics of SCR

- When a reverse voltage is applied to the SCR, the device functions in basically the same manner as a reverse-biased PN junction diode.
- As the reverse voltage ( $V_R$ ) across the SCR increases from zero, only a small reverse current ( $I_R$ ) will flow through the device due to leakage.

## I-V Characteristics of SCR

- This current will remain small until  $V_R$  becomes large enough to cause the SCR to breakdown. Then  $I_R$  will increase rapidly if  $V_R$  increases even slightly above the breakdown point.

**(the curve is almost vertical and straight).**

## I-V Characteristics of SCR

- **The reverse voltage** ( $V_R$ ) required to breakdown the SCR is referred to as the SCR's Reverse Breakdown Voltage. If too much reverse current is allowed to flow through the SCR after breakdown occurs, the device could be permanently damaged.
- However, this situation is normally avoided because the SCR is usually subjected to operating voltages which are well below its **breakdown rating**.

# Applications of SCR

## 1. *Power Control.*

- Because of the **bistable characteristics** of semiconductor devices, they can be switched **on and off**, and the efficiency of gate control to trigger such devices.
- SCRs are ideally suited for many industrial applications.
- SCRs have got specific advantages over **saturable core reactors** and **gas tubes** owing to their compactness, reliability, low losses, and speedy turn-on and turn-off.

# Applications of SCR

- The bistable states (conducting and non-conducting) of the SCR and the property that enables fast transition from one state to the other are made use of in the control of power in both ac and dc circuits.

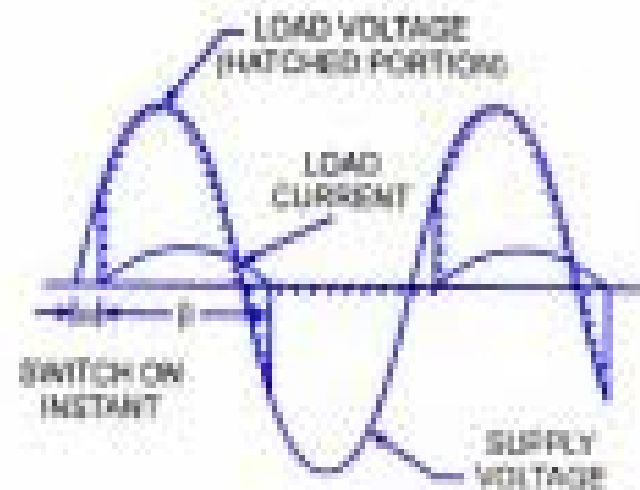
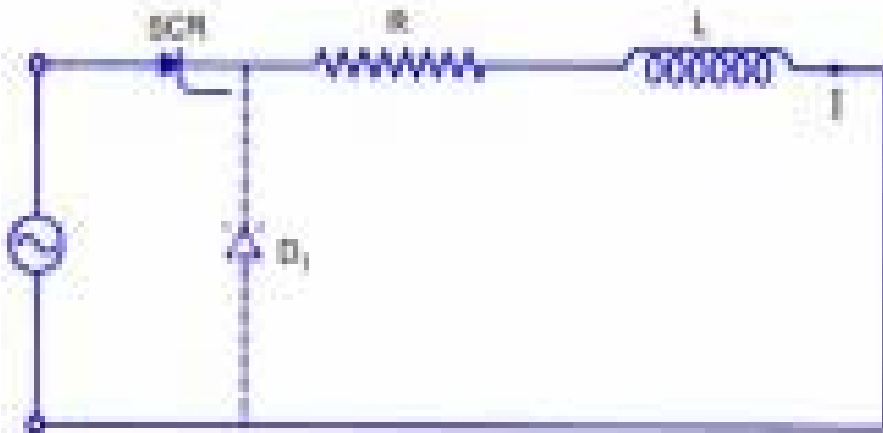

*Phase Control*



# Applications of SCR

- In ac circuits the SCR can be turned-on by the gate at any angle  $\alpha$  with respect to applied voltage. This angle  $\alpha$  is called the firing angle and power control is obtained by varying the firing angle. This is known as phase control.
- The SCR will turn-off by natural commutation when the current becomes zero. Angle  $\beta$  is known as the conduction angle.
- By varying the firing angle  $a$ , the rms value of the load voltage can be varied. The power consumed by the load decreases with the increase in firing angle  $a$ .

## Conti....

- With this diode, SCR will be turned-off as soon as the input voltage polarity reverses. After that, the load current will free wheel through the diode and a reverse voltage will appear across the SCR.
- The main advantage of phase control is that the load current passes through a natural zero point during every half cycle. So, the device turns-off by itself at the end of every conducting period and no other commutating circuit is required.

# Applications of SCR

2. **Switching Thyristor**, being bistable device is widely used for switching of power signals, high operation speed and freedom from other defects associated with electro-mechanical switches.

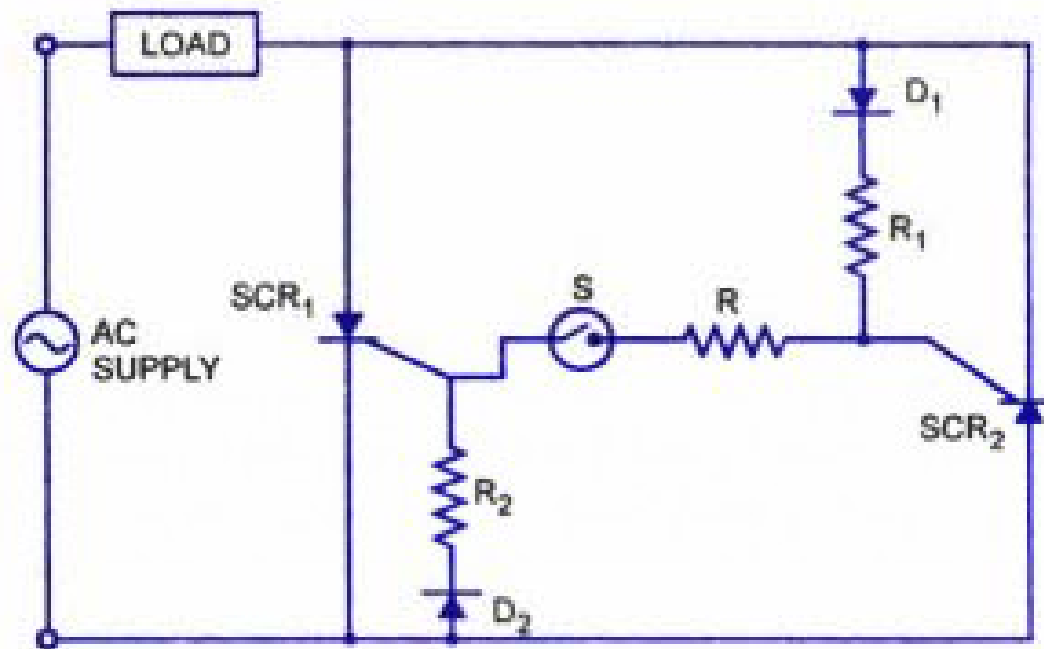

*Static AC Circuit Breaker*

# Applications of SCR

- Two SCRs are used for making and breaking an ac circuit.
- For starting the circuit, when switch S is closed, SCR1 will fire at the beginning of the positive half-cycle (the gate trigger current is assumed to be very small) because during positive half cycle SCR1 is forward biased.
- It will turn-off when the current goes through the zero value. As soon as SCR1 is turned-off, SCR2 will fire since the voltage polarity is already reversed and it gets the proper gate current.

## Applications of SCR

- The circuit can be broken by opening the switch S. Opening of gate circuit poses no problem, as current through this switch is small.
- As no further gate signal will be applied to the SCRs when switch S is open, the SCRs will not be triggered and the load current will be zero. **The maximum time delay for breaking the circuit is one half-cycle.**

# Applications of SCR

## 3. Zero Voltage Switching.

- In some ac circuits, it is necessary to apply the voltage to the load when the instantaneous value of this voltage is going through the zero value.

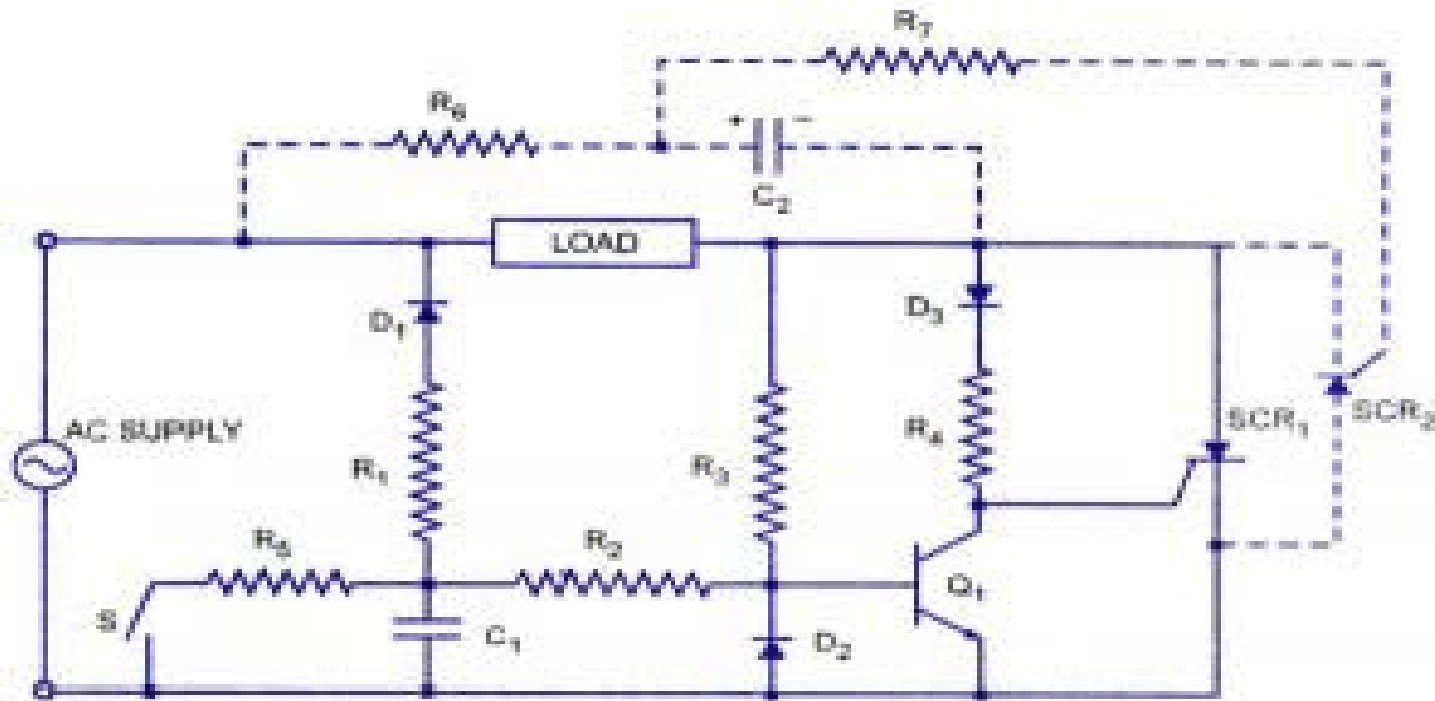

*Zero-Voltage Switching*

# Applications of SCR

- This is to avoid a high rate of increase of current in case of purely resistive loads, thereby reduce the generation of radio noise and hot-spot temperatures in the device carrying the load current.
- The portion of the circuit shown by the dotted lines relates to the negative half cycle. Whatever may be the instant of time when switch S is opened only at the beginning of the following positive half-cycle of the applied voltage SCR1 will be triggered.

# Applications of SCR

- Similarly, when switch S is closed, SCR1 will stop conducting at the end of the present or previous positive half-cycle and will not get triggered again. Resistors R3 and R4 are designed on the basis of minimum base and gate currents required for transistor Q1 and SCR1.
- Resistors R1 and R2 govern rates of the charging and discharging of capacitor C1. Resistor R5 is used for preventing large discharge currents when switch S is closed.



# Applications of SCR

## 4. *Over-Voltage Protection.*

- SCRs can be employed for protecting other equipment from over-voltages owing to their fast switching action. The SCR employed for protection is connected in parallel with the load.
- Whenever the voltage exceeds a specified limit, the gate of the SCR will get energized and trigger the SCR.
- A large current will be drawn from the supply mains and voltage across the load will be reduced.

# Applications of SCR

- Two SCRs are used—one for the positive half-cycle and the other for negative half-cycle. Resistor R1 limits the short-circuit current when the SCRs are fired.
- **ZENER** diode D5 in series with resistors Rx and R2 constitutes a voltage-sensing circuit.

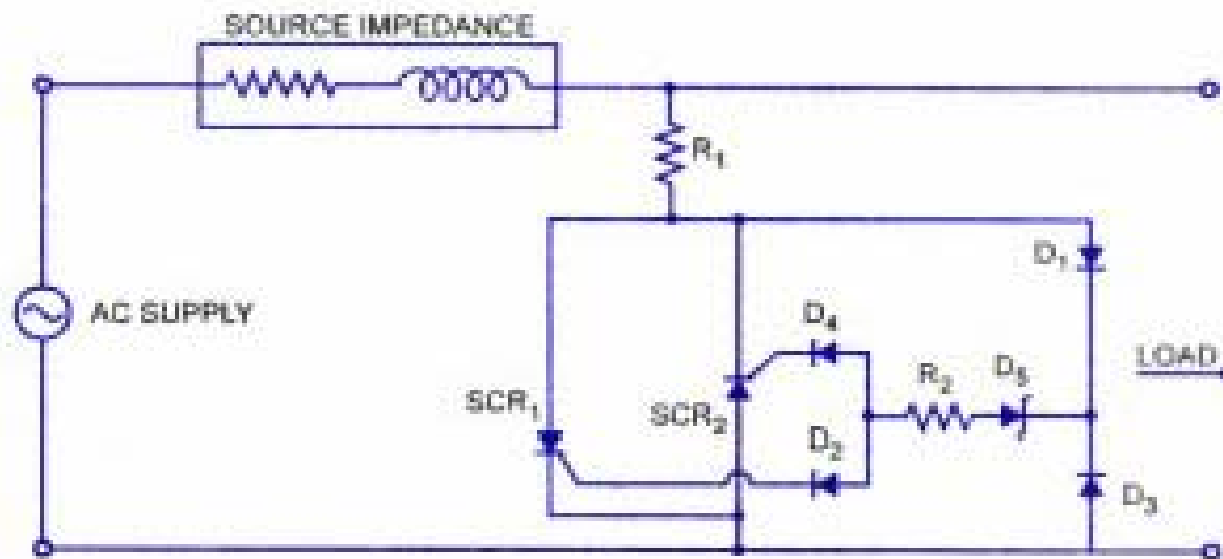

*Over-Voltage Protection Circuit*

# Applications of SCR

## 5. Pulse Circuits.

- SCRs are used for producing high voltage/current pulses of desired waveform and duration.

The capacitor C is charged during the positive half cycle of the input supply and the SCR is triggered during the negative half-cycle.

The capacitor will discharge through the output circuit, and when the **SCR forward current** becomes zero, it will turn-off.

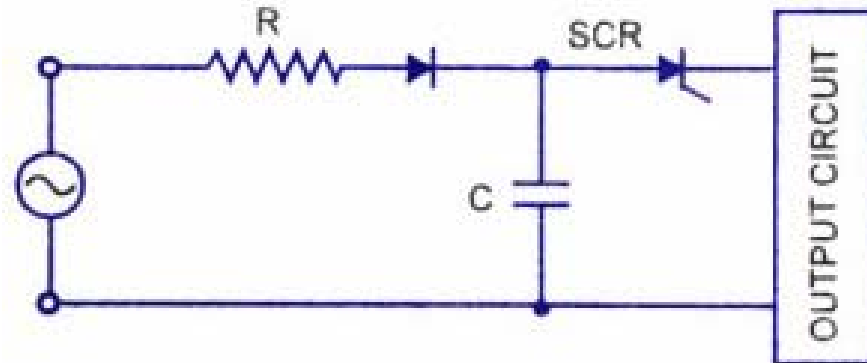

*Pulse Circuit*

# Applications of SCR

- The output circuit is designed to have discharge current of less than a milli-second duration.
- The capacitor will again get charged in the following positive half-cycle and the SCR will be triggered again in the negative half-cycle.
- Thus the frequency of the output pulse will be equal to the frequency of the input supply.
- For limiting the charging current resistor  $R$  is used. High voltage/current pulses can be used in spot welding, electronic ignition in automobiles, generation of large magnetic fields of short duration, and in testing of insulation.

# Applications of SCR

## 6. Battery Charging Regulator.

- Diodes D1 and D2 are to establish a full-wave rectified signal across SCR1 and the 12 V battery to be charged.
- When the full-wave rectified input is large enough to give the required turn-on gate current (controlled by resistor R1), SCR1 will turn on and the charging of the battery will commence.

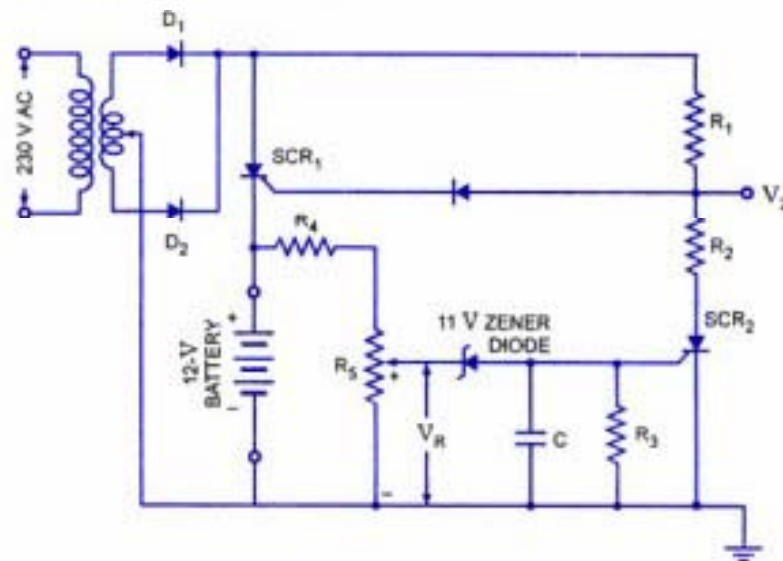

*Battery Charging Regulator*

# Applications of SCR

- At the commencement of charging of battery, voltage  $V_R$  determined by the simple voltage-divider circuit is too small to cause 11.0 V zener conduction.
- In the off-state Zener diode is effectively an open-circuit maintaining SCR2 in the off-state because of zero gate current.
- The capacitor C is included in the circuit to prevent any voltage transients in the circuit from accidentally turning on of the SCR2.

# Applications of SCR

- As charging continues, the battery voltage increases to a point when  $V_R$  is large enough to both turn on the 11.0 V Zener diode and fire SCR2.
- Once SCR2 has fired, the short circuit representation for SCR2 will result in a voltage-divider circuit determined by R1 and R2 that will maintain  $V_2$  at a level too small to turn SCR1 on.

# Applications of SCR

- When this occurs, the battery is fully charged and the open-circuit state of SCR1 will cut off the charging current.
- Thus the regulator charges the battery whenever the voltage drops and prevents overcharging when fully charged.
- There are many more applications of SCRs such as in soft start circuits, logic and digital circuits, but it is not possible to discuss all these here.