

**SECTION – A (75 MARKS )**

This question consists of TWENTY FIVE sub-question (1.1 – 1.25) of ONE mark each. For each of these sub-questions, four possible alternatives (A, B, C and D) are given, out of which only one is correct. Indicate the correct answer by darkening the appropriate bubble against the question number on the left hand side of the objective Response Sheet (ORS). You may use the answer book provided for any rough work, if needed.

1.1 The dependent current source shown in given figure.

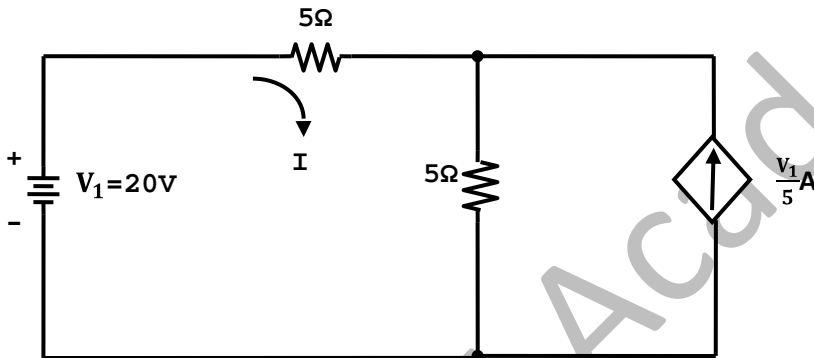

- (A) Delivers 80 W
- (B) absorbs 80W

- (C) Delivers 40 W
- (D) absorbs 40 W

1.2 In given figure 1.2, the switch was closed for a long time before opening at  $t = 0$ . The voltage  $V_x$  at  $t = 0^+$  is

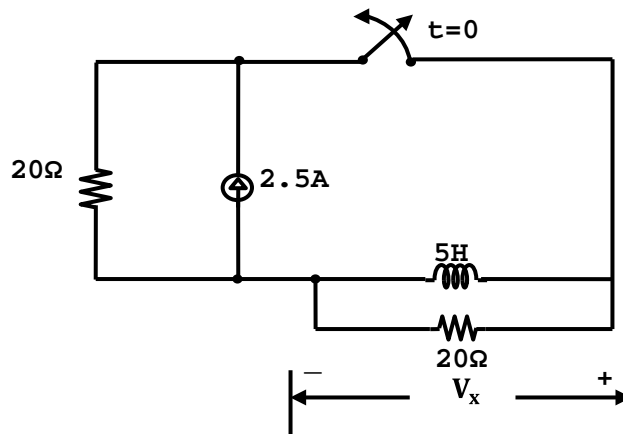

- (A) 25 V
- (B) 50V

- (C) -50 V
- (D) 0V

1.3 Convolution of  $x(t+5)$  with impulse function  $\delta(t-7)$  is equal to

- (A)  $x(t - 12)$
- (B)  $x(t + 12)$

- (C)  $x(t - 2)$
- (D)  $x(t + 2)$

1.4 Which of the following cannot be the Fourier series expansion of a periodic signal?

- (A)  $x(t) = 2\cos t + 3 \cos 3t$
- (B)  $x(t) = 2\cos \pi t + 7 \cos t$
- (C)  $x(t) = \cos t + 0.5$

- (D)  $x(t) = 2\cos 1.5\pi t + \sin 3.5\pi t$
- (E)

1.5 In given figure a silicon diode is carrying a constant current of 1mA. When the temperature of the diode is  $20^\circ\text{C}$ ,  $V_D$  is found to be 700 mV. If the temperature rises to  $40^\circ\text{C}$ ,  $V_D$  becomes approximately equal to

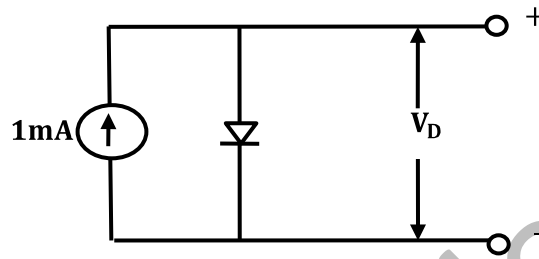

- (A) 740 mV (C) 680 mV  
(B) 660mV (D) 700 mV

1.6 In a negative feedback amplifier using voltage-series (i.e. Voltage-sampling, series mixing) feedback.

- (A)  $R_i$  decreases and  $R_o$  decreases (C)  $R_i$  increases and  $R_o$  decreases  
(B)  $R_i$  decreases and  $R_o$  increases (D)  $R_i$  increases and  $R_o$  increases  
( $R_i$  and  $R_o$  denote the input and output resistances respectively )

1.7 A 741-type opamp has a gain-bandwidth product of 1 MHz. A non-inverting amplifier using this opamp and having a voltage gain of 20 dB will exhibit a – 3-dB bandwidth of

- (A) 50 kHz (C)  $\frac{1000}{17}$  kHz  
(B) 100kHz (D)  $\frac{1000}{7.07}$  kHz

1.8 Three identical RC-coupled transistor amplifiers are cascaded. If each of the amplifiers has a frequency response as shown in the figure is the overall frequency response is as given in

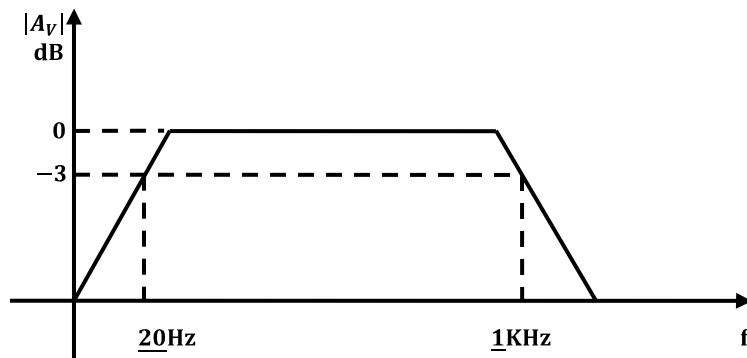

(A)

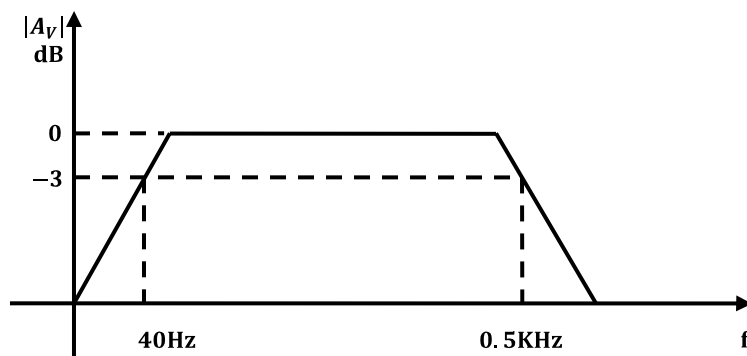



1.11 The number of comparators required in a 3-bit comparator type ADC is

- (A) 2 (C) 7  
(B) 3 (D) 8

1.12 If the transistor in the figure is in saturation, then

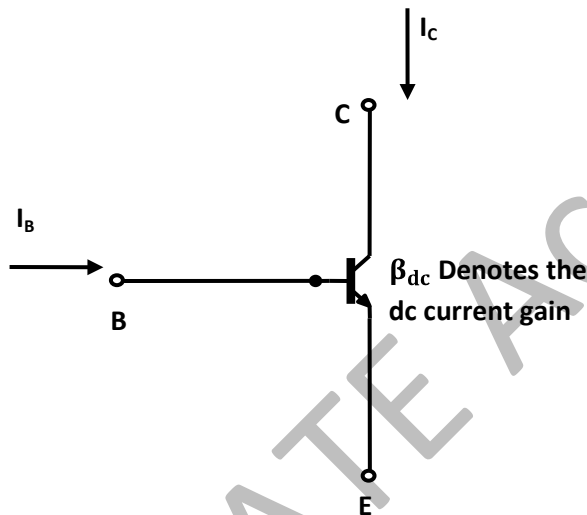

- (A)  $I_C$  is always equal to  $\beta_{dc} I_B$  (C)  $I_C$  is greater than or equal to  $\beta_{dc} I_B$   
(B)  $I_C$  is always equal to  $-\beta_{dc} I_B$  (D)  $I_C$  is less than or equal to  $\beta_{dc} I_B$

1.13 Consider a system with the transfer function  $G(s) = \frac{s+6}{ks^2+s+6}$ . Its damping ratio will be 0.5 when the value of k is

- (A) 2/6 (C) 1/6  
(B) 3 (D) 6

1.14 Which of the following points is NOT on the root locus of a system with the open-loop transfer function  $G(s)H(s) = \frac{k}{s(s+1)(s+3)}$

- (A)  $s = -j\sqrt{3}$  (C)  $s = -3$   
(B)  $s = -1.5$  (D)  $s = -\infty$

1.15 The phase margin of a system with the open-loop transfer function  $G(s)H(s) = \frac{(1-s)}{(1+s)(2+s)}$  is

- (A)  $0^\circ$  (C)  $90^\circ$   
(B)  $63.4^\circ$  (D)  $\infty$

1.16 The transfer function  $Y(s)/U(s)$  of a system described by the state equations  $\dot{x}(t) = -2x(t) + 2u(t)$  and  $y(t) = 0.5x(t)$  is

- (A)  $0.5/(s-2)$  (C)  $0.5/(s+2)$   
(B)  $1/(s-2)$  (D)  $1/(s+2)$

1.17 The Fourier transform  $F\{e^{-t}u(t)\}$  is equal to  $\frac{1}{1+j2\pi f}$ . Therefore,  $F\left\{\frac{1}{1+j2\pi t}\right\}$  is

- (A)  $e^f u(f)$  (C)  $e^f u(-f)$   
(B)  $e^{-f} u(f)$  (D)  $e^{-f} u(-f)$

1.18 A linear phase channel with phase delay  $T_p$  and group delay  $T_g$  must have

- (A)  $T_p = T_g = \text{constant}$  (B)  $T_p \propto f$  and  $T_g \propto f$

(C)  $T_p = \text{constant}$  and  $T_g \propto f$   
(f denotes frequency)

(D)  $T_p \propto f$  and  $t_g = \text{constant}$

- 1.19 A 1 MHz sinusoidal carrier is amplitude modulated by symmetrical square wave of period 100  $\mu$  sec. Which of the following frequencies will NOT be present in the modulated signal?  
 (A) 990 kHz (C) 1020 kHz  
 (B) 1010 kHz (D) 1030 kHz
- 1.20 Consider a sampled signal  $y(t) = 5 \times 10^{-6} x(t) \sum_{n=-\infty}^{+\infty} \delta(t - nT_s)$  where  $x(t) = 10 \cos(8\pi \times 10^3)t$  and  $T_s = 100 \mu\text{sec}$ . When  $y(t)$  is passed through an ideal lowpass filter with a cut-off frequency of 5 kHz, the output of the filter is  
 (A)  $5 \times 10^{-6} \cos(8\pi \times 10^3)t$  (C)  $5 \times 10^{-1} \cos(8\pi \times 10^3)t$   
 (B)  $5 \times 10^{-5} \cos(8\pi \times 10^3)t$  (D)  $10 \cos(8\pi \times 10^3)t$
- 1.21 For a bit-rate of 8 kbps, the best possible values of the transmitted frequency in a coherent binary FSK system are  
 (A) 16 kHz and 20 kHz (C) 20 kHz and 40 kHz  
 (B) 20 kHz and 32 kHz (D) 32 kHz and 40 kHz
- 1.22 The line-of-sight communication requires the transmit and receive antennas to face each other. If the transmit antenna is vertically polarized, for best reception the receive antenna should be  
 (A) horizontally polarized  
 (B) vertically polarized  
 (C) at  $45^\circ$  with respect to horizontal polarization.  
 (D) at  $45^\circ$  with respect to vertical polarization.
- 1.23 The VSWR can have any value between  
 (A) 0 and 1 (C) 0 and  $\infty$   
 (B) -1 and +1 (D) 1 and  $\infty$
- 1.24 In an impedance Smith chart, a clockwise movement along a constant resistance circle gives rise to  
 (A) a decrease in the value of reactance.  
 (B) an increase in the value of reactance .  
 (C) no change in the reactance value.  
 (D) no change in the impedance value.
- 1.25 The phase velocity for the  $TE_{10}$ -mode in an air-filled rectangular waveguide is  
 (A) less than c (C) Greater than c  
 (B) Equal to c (D) None of the above  
 (c is the velocity of plane waves in free space)

2. This question consists of TWENTY FIVE sub-questions (2.1 – 2.25) of TWO marks each. For each of these sub-questions, four alternatives (A, B, C and D) are given, out of which only one is correct. Indicate the correct answer by darkening the appropriate bubble against the question number on the left hand side of the Objective Response Sheet (ORS). You may use the answer book provided for any rough work, if needed.

2.1 In the network of the figure is the maximum power is delivered to  $R_L$  if its value is

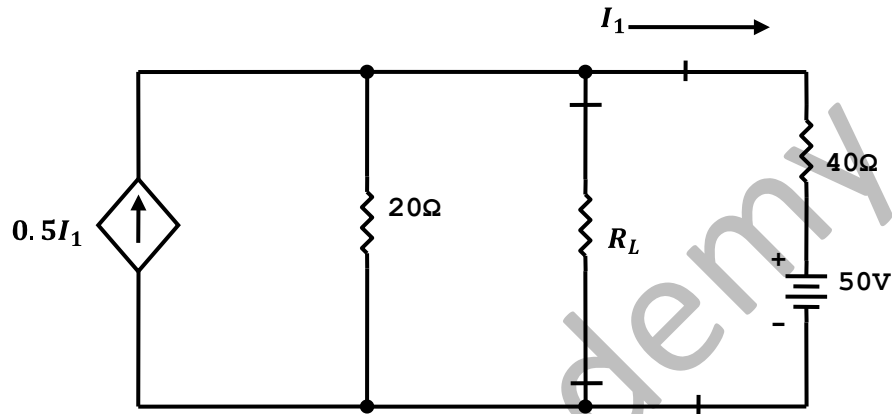

- (A) 16 Ω
- (B)  $\frac{40}{3}$  Ω
- (C) 60 Ω
- (D) 20 Ω

2.2 If the 3-phase balanced source in the figure delivers 1500W at a leading power factor of 0.844, then the value of  $Z_L$  (in ohm) is approximately

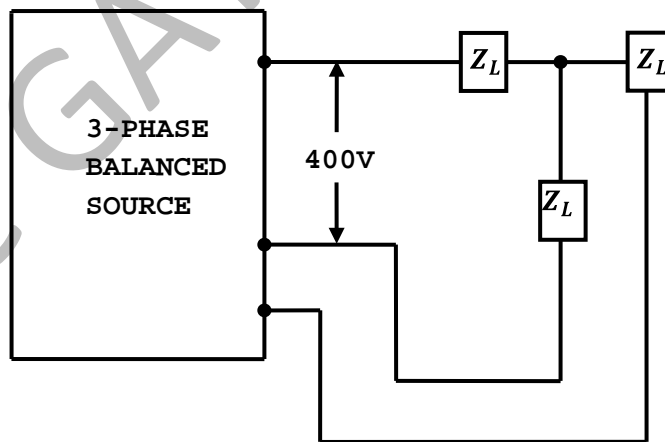

- (A)  $90 \angle 32.44^\circ$
- (B)  $80 \angle 32.44^\circ$
- (C)  $80 \angle -32.44^\circ$
- (D)  $90 \angle -32.44^\circ$

2.3 The Laplace transform of a continuous-time signal  $x(t)$  is  $X(s) = \frac{5-s}{s^2-s-2}$ . If the Fourier transform of this signal exists, then  $x(t)$  is

- (A)  $e^{2t}u(t) - 2e^{-t}u(t)$
- (B)  $-e^{2t}u(-t) + 2e^{-t}u(t)$
- (C)  $-e^{2t}u(-t) - 2e^{-t}u(t)$
- (D)  $e^{2t}u(-t) - 2e^{-t}u(t)$

2.4 If the impulse response of a discrete-time system is  $h[n] = -5^n u[-n-1]$ , then the system function  $H(z)$  is equal to

- (A)  $\frac{-z}{z-5}$  and the system is stable
- (B)  $\frac{z}{z-5}$  and the system is stable
- (C)  $\frac{-z}{z-5}$  and the system is unstable
- (D)  $\frac{z}{z-5}$  and the system is unstable

2.5 An amplifier using an opamp with a slew-rate  $SR=1$  V/ $\mu$ sec has a gain of 40dB. If this amplifier has to faithfully amplify sinusoidal signals from dc to 20 kHz without introducing any slew-rate induced distortion, then the input signal level must not exceed.

- (A) 795mV
- (B) 395mV
- (C) 79.5mV
- (D) 39.5mV

2.6 The circuit in figure employs positive feedback and is intended to generate sinusoidal oscillation. If at a frequency  $f_0$ ,  $B(f) = \Delta \frac{V_f(f)}{V_o(f)} = \frac{1}{6} \angle 0^\circ$ , then to sustain oscillation at this frequency

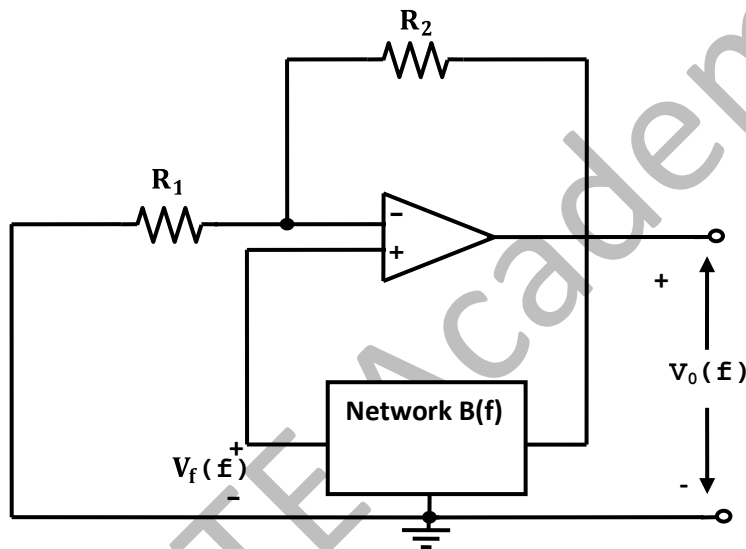

- (A)  $R_2 = 5R_1$
- (B)  $R_2 = 6R_1$
- (C)  $R_2 = \frac{R_1}{6}$
- (D)  $R_2 = \frac{R_1}{5}$

2.7 A zener diode regulator in the figure is to be designed to meet the specifications:  $I_L = 10 \text{ mA}$ ,  $V_0 = 10 \text{ V}$  and  $V_m$  varies from  $30 \text{ V}$  to  $50 \text{ V}$ . The zener diode has  $V_z = 10 \text{ V}$  and  $I_{zk}$  (knee current) =  $1 \text{ mA}$ . For satisfactory operation.

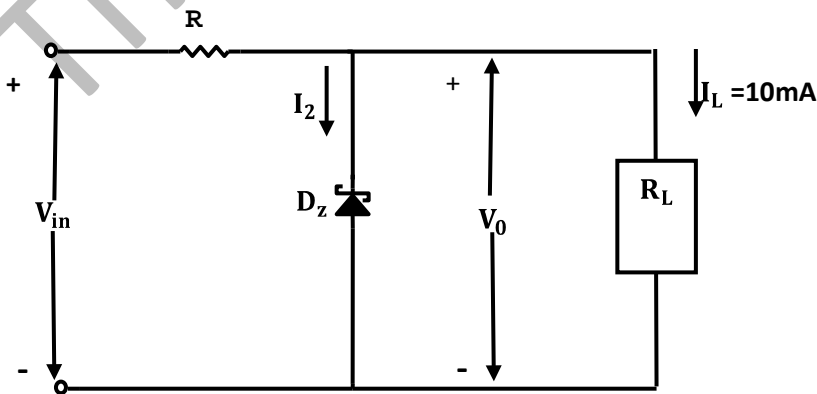

- (A)  $R \leq 1800\Omega$
- (B)  $2000\Omega \leq R \leq 2200\Omega$
- (C)  $3700\Omega \leq R \leq 4000\Omega$
- (D)  $R > 4000\Omega$

2.8 The voltage gain  $A_v = \frac{V_o}{V_i}$  of the JFET amplifier shown in the figure is

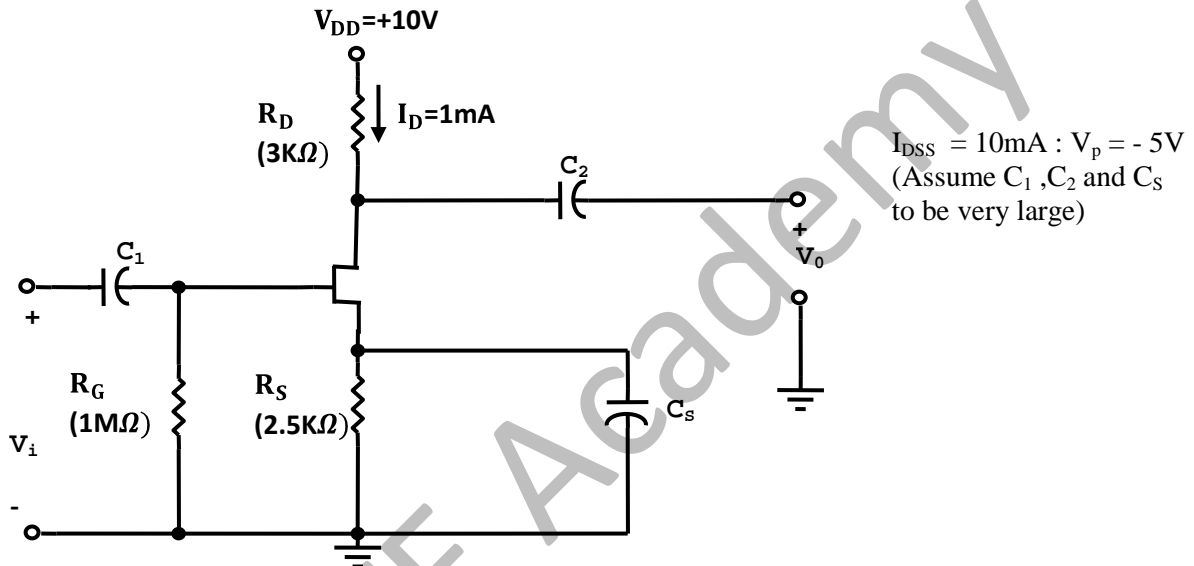

- (A) +18  
(B) -18  
(C) +6  
(D) -6

2.9 The gates  $G_1$  and  $G_2$  in the figure have propagation delays of 10 nsec and 20 nsec respectively. If the input  $V_i$  makes an abrupt change from logic 0 to 1 at time  $t=t_0$ , then the output waveform  $V_o$  is.

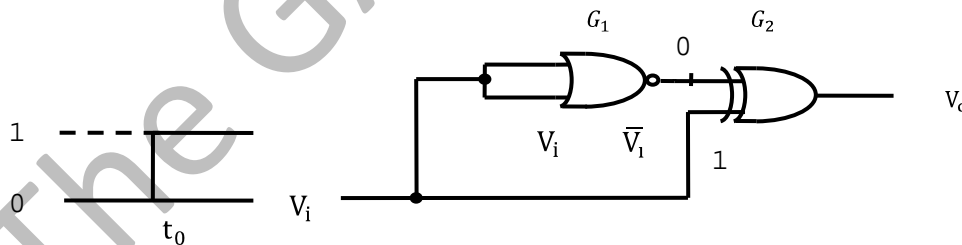

- (A)
- (B)
- (C)
- (D)



2.10 The circuit in the figure has two CMOS NOR-gates. This circuit functions as a

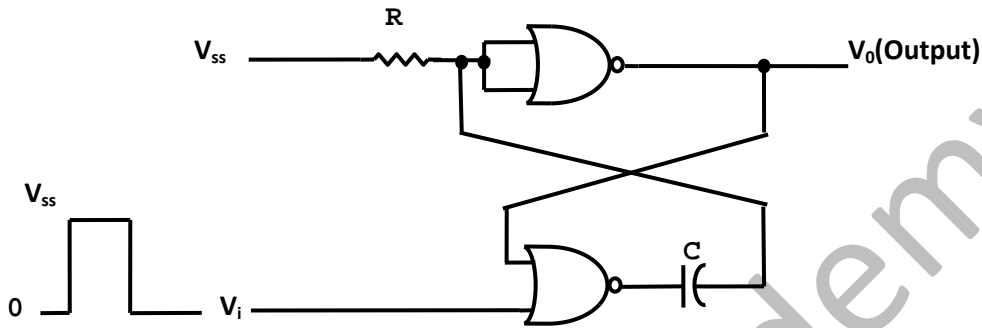

- (A) flip-flop  
(B) schmitt trigger  
(C) monostable multivibrator  
(D) astable multivibrator

2.11 Consider the following statements in connection with the CMOS inverter in the figure is where both the MOSFETs are of enhancement type and both have a threshold voltage of 2 V.

Statement 1 :  $T_1$  conducts when  $V_i \geq 2$  V.

Statement 2 :  $T_1$  is always in saturation when  $V_0 = 0$ V.

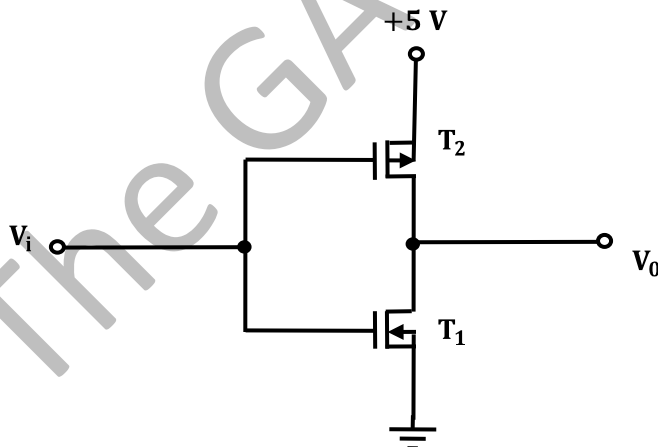

Which of the following is correct?

- (A) Only statement 1 is TRUE  
(B) Only statement 2 is TRUE  
(C) Both the statements are TRUE  
(D) Both the statements are FALSE

2.12 If the input  $X_3, X_2, X_1, X_0$  to the ROM in the figure are 8-4-2-1 BCD numbers, then the outputs  $Y_3 Y_2 Y_1 Y_0$  are

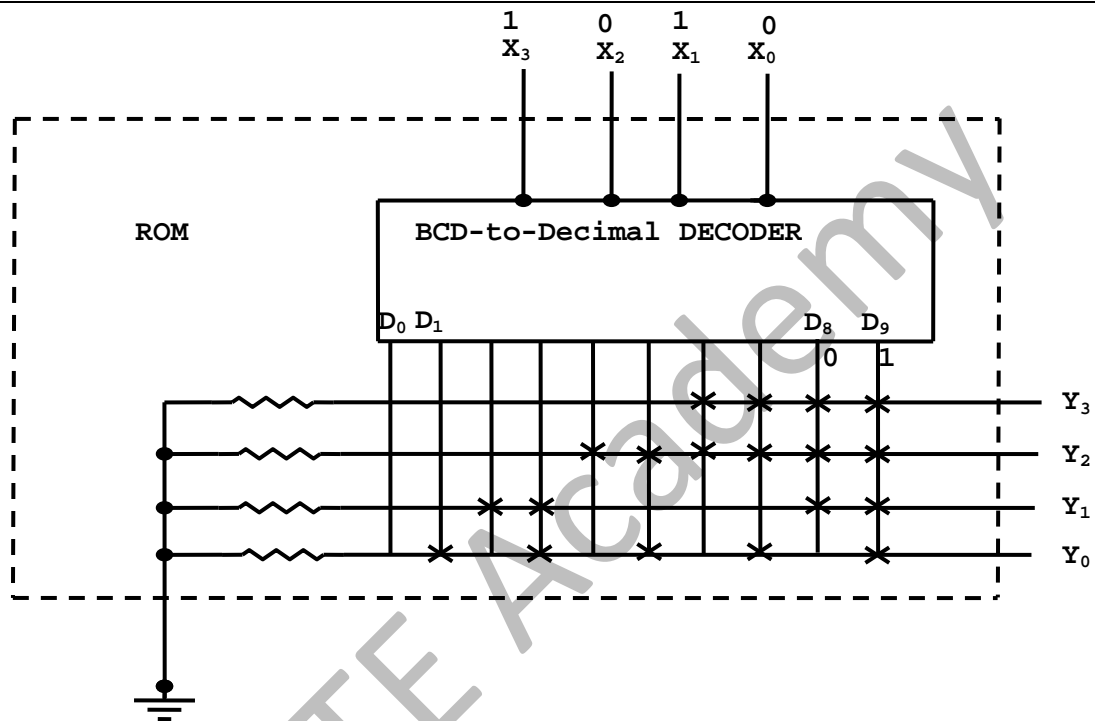

- (A) gray code numbers  
(B) 2-4-2-1 BCD numbers  
(C) excess-3 code numbers  
(D) none of the above

2.13 Consider the following assembly language program.

```

MVI    B,87H
MOV    A, B
START : JMP    NEXT
MVI    B, 00H
XRA    B
OUT    PORT1
HLT
NEXT : XRA    B
      JP     START
      OUT   PORT 2
      HLT
    
```

The execution of the above program in an 8085 microprocessor will result in

- (A) An output of 87H at PORT1  
(B) An output of 87H at PORT2  
(C) Infinite looping of the program execution with accumulator data remaining at 00H.  
(D) Infinite looping of the program execution with accumulator data alternating between 00H and 87H.

2.14 The system shown in the figure remains stable when

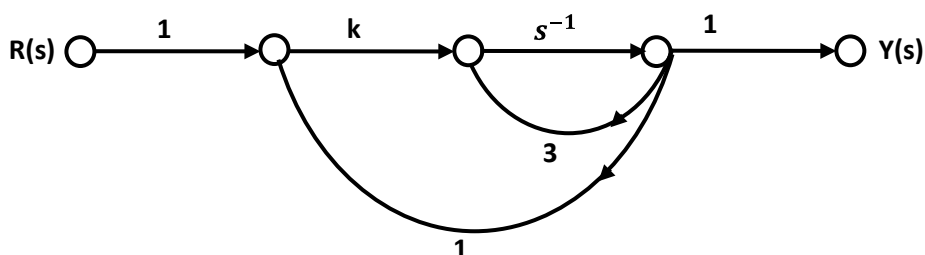

- (A)  $k < -1$  (C)  $1 < k < 3$   
 (B)  $-1 < k < 1$  (D)  $k > 3$

2.15 The transfer function of a system is  $G(s) = \frac{100}{(s+1)(s+100)}$ . For a unit-step input to the system the approximate settling time for 2% criterion is

- (A) 100 sec (C) 1 sec  
 (B) 4 sec (D) 0.01 sec

2.16 The characteristic polynomial of a system is  $q(s) = 2s^5 + s^4 + s^3 + s^2 + 2s + 1$ . The system is  
 (A) stable (C) unstable  
 (B) marginally stable (D) oscillatory

2.17 The system with the open loop transfer function  $G(s)H(s) = \frac{1}{s(s^2 + s + 1)}$  has a gain margin of  
 (A) -6 dB (C) 3.5 dB  
 (B) 0 dB (D) 6 dB

2.18 An angle-modulated signal is given by  $s(t) = \cos 2\pi(2 \times 10^6 t + 30 \sin 150t + 40 \cos 150t)$ . The maximum frequency and phase deviations of  $s(t)$  are  
 (A) 10.5 kHz,  $140\pi$  rad  
 (B) 6 kHz,  $80\pi$  rad  
 (C) 10.5 kHz,  $100\pi$  rad  
 (D) 7.5 kHz,  $100\pi$  rad

2.19 In the figure  $m(t) = \frac{2 \sin 2\pi t}{t}$ ,  $s(t) = \cos 200\pi t$  and  $n(t) = \frac{\sin 199\pi t}{t}$ . The output  $y(t)$  will be

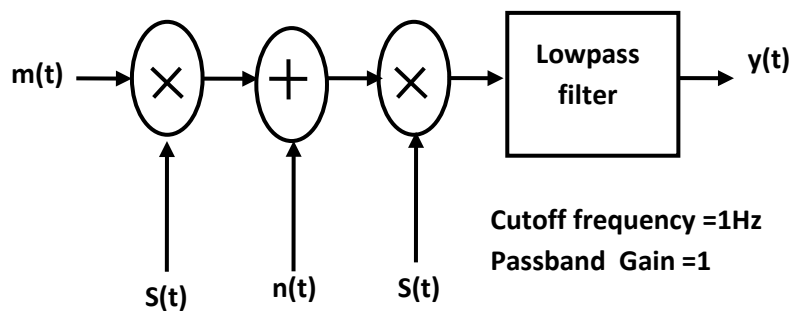

- (A)  $\frac{\sin 2\pi t}{t}$  (C)  $\frac{\sin 2\pi t}{t} + \frac{\sin 0.5\pi t}{t} \cos 1.5\pi t$   
 (B)  $\frac{\sin 2\pi t}{t} + \frac{\sin \pi t}{t} \cos 3\pi t$  (D)  $\frac{\sin 2\pi t}{t} + \frac{\sin \pi t}{t} \cos 0.75\pi t$

2.20 A signal  $x(t) = 100 \cos(24\pi \times 10^3)t$  is ideally sampled with a sampling period of 50  $\mu$ sec and then passed through an ideal low pass filter with cut-off frequency of 15 kHz. Which of the following frequencies is/are present at the filter output?

- (A) 12 kHz only (C) 12 kHz and 9 kHz  
 (B) 8 kHz only (D) 12 kHz and 8 kHz

2.21 If the variance  $\sigma_x^2$  of  $d(n) = x(n) - x(n-1)$  is one tenth the variance  $\sigma_x^2$  of a stationary zero-mean discrete-time signal  $x(n)$ , then the normalized autocorrelation function  $R_{xx}(k)/\sigma_x^2$  at  $k=1$  is

- (A) 0.95 (C) 0.10  
(B) 0.90 (D) 0.05

- 2.22 A plane wave is characterized by  $\vec{E} = (0.5\hat{x} + \hat{y}e^{j\pi/2})e^{j\omega t - jkz}$ . This wave is  
(A) linearly polarized (C) elliptically polarized  
(B) circularly polarized (D) unpolarized
- 2.23 Distilled water at 25° C is characterized by  $\sigma = 1.7 \times 10^{-4} \text{ mho/m}$  and  $\epsilon = 78\epsilon_0$  at a frequency of 3 GHz. Its loss tangent  $\tan \delta$  is  
(A)  $1.3 \times 10^{-5}$   
(B)  $1.3 \times 10^{-3}$   
(C)  $1.7 \times \frac{10^{-4}}{78}$   
(D)  $1.7 \times 10^{-4} / (78\epsilon_0)$   
( $\epsilon = 10^{-9} / (36\pi) \text{ F/m}$ )
- 2.24 The electric field on the surface of a perfect conductor is 2V/m. The conductor is immersed in water with  $\epsilon = 80\epsilon_0$ . The surface charge density on the conductor is  
(A)  $0 \text{ C/m}^2$  (C)  $1.8 \times 10^{-11} \text{ C/m}^2$   
(B)  $2 \text{ C/m}^2$  (D)  $1.14 \times 10^{-9} \text{ C/m}^2$   
( $\epsilon = 10^{-9} / (36\pi) \text{ F/m}$ )
- 2.25 A person with a receiver is 5 Km away from the transmitter. What is the distance that this person must move further to detect a 3-dB decrease in signal strength?  
(A) 942 m (C) 4978 m  
(B) 2070 m (D) 5320 m

**SECTION – B (75 Marks)**

This section consists of TWENTY questions (EC3 – EC22) of FIVE marks each. Attempt ANY FIFTEEN questions. Answers must be given in the answer book provided. Answer for each question must start on a fresh page and must appear at one place only (Answers to all parts of a question must appear together).

3. The switch in the figure is has been in position 1 for a long time and is, then moved to position 2 at  $t = 0$ .

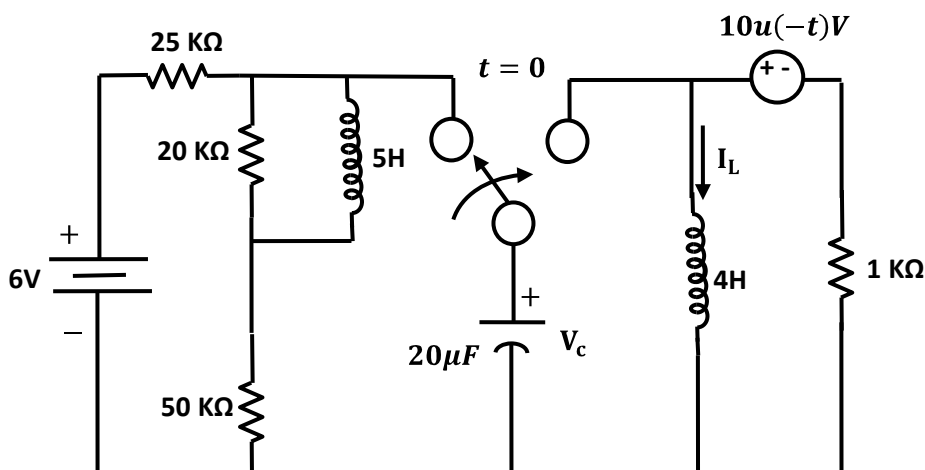

- (A) Determine  $V_C(0^+)$  and  $I_L(0^+)$ .  
(B) Determine  $\frac{dV_C(t)}{dt}$  at  $t = 0^+$ .  
(C) Determine  $V_C(t)$  for  $t > 0$ .

4. For the network shown in the figure is  $R = 1 \text{ K}\Omega$ ,  $L_1 = 2 \text{ H}$ ,  $L_2 = 5 \text{ H}$ ,  $L_3 = 1 \text{ H}$ ,  $L_4 = 4 \text{ H}$  and  $C = 0.2 \text{ }\mu\text{F}$ . The mutual inductances are  $M_{12} = 3 \text{ H}$  and  $M_{34} = 2 \text{ H}$ . Determine
- the equivalent inductance for the combination of  $L_3$  and  $L_4$ .
  - the equivalent inductance across the points A and B in the network.
  - the resonant frequency of the network.

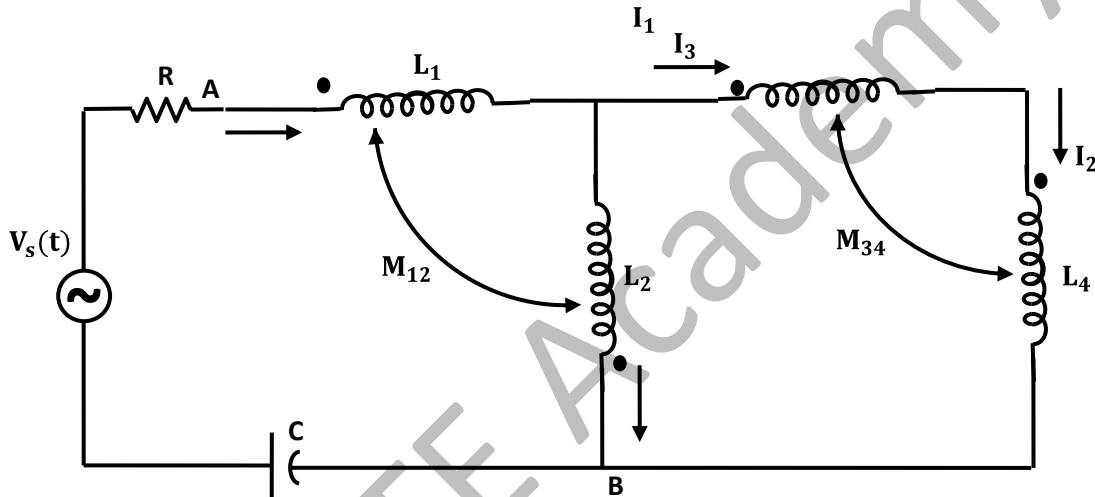

5. Consider the network in the given figure

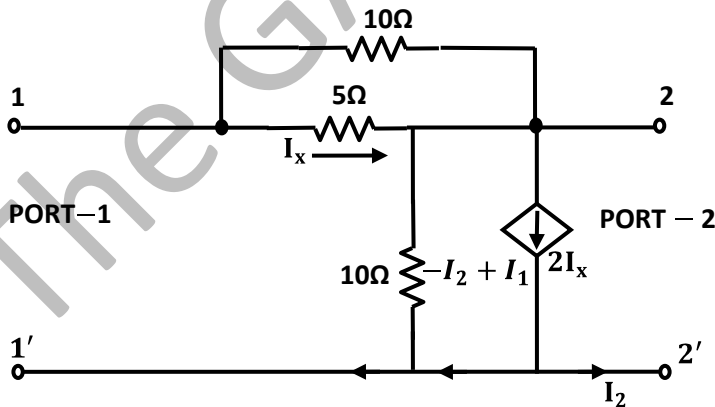

- Find its short-circuit admittance parameters.
  - Find the open-circuit impedance  $Z_{22}$ .
6. A triangular voltage waveform  $V_i(t)$  first figure applied at the input to the circuit of second figure. Assume the diodes to be ideal.

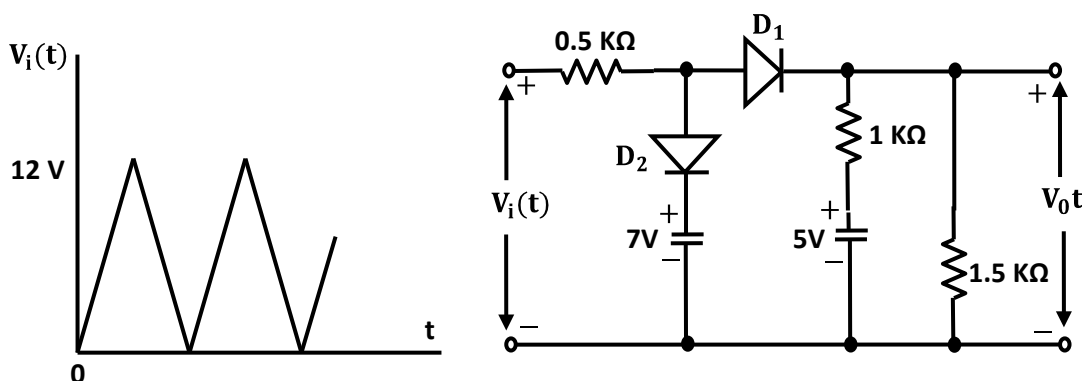

- (A) Determine the output  $V_0(t)$ .  
 (B) Neatly sketch the output waveform superimposed on the input  $V_i(t)$  and label the key points.

7. The given figure shows 2-stage amplifier. The transistors  $Q_1$  and  $Q_2$  are identical with current gain  $\beta = 100$ ; further  $\beta_{ac} = \beta_{dc} = \beta$ . The zener diode  $D_z$  has a break-down voltage  $V_z = 10.7$  volt. Assume that  $D_z$  is in break-down region and its dynamic resistance  $r_z$  is zero. The capacitors  $C_1$  and  $C_2$  are large and provide negligible impedance at signal frequencies.

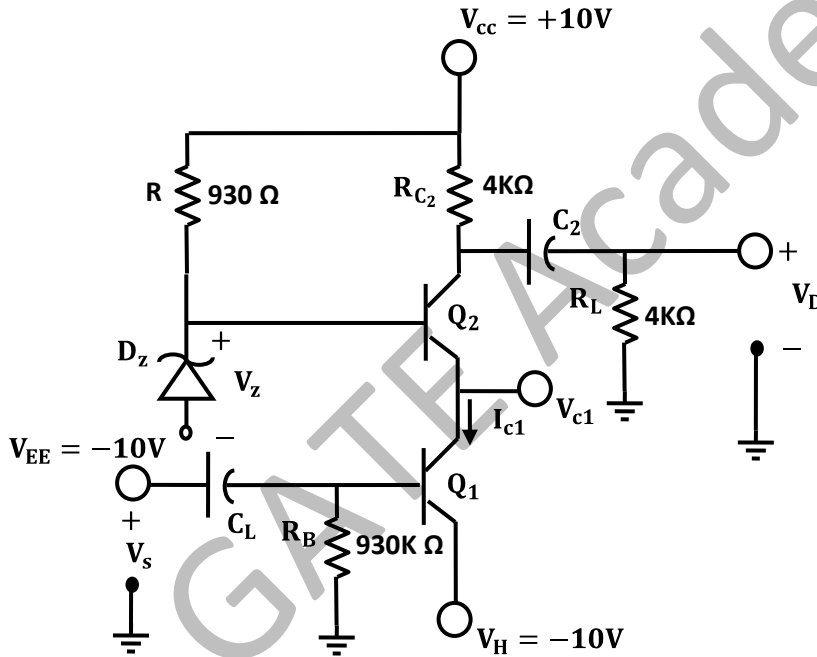

- (A) Identify the configuration in each of the amplifier stages (i.e. whether CE, CC, CB etc.)  
 (B) Determine the quiescent quantities  $I_{C1}$  and  $V_{C1}$ .  
 (C) Derive an expression for the voltage gain  $A_V$   
 $\Delta \frac{v_0}{v_s}$  and determine its value.

(Assume  $V_{BE} = 0.7$  V,  $r_0 = \infty$  and Thermal voltage  $V_T = 25$  mV)

8. Consider the circuit of the figure is. The opamp used is ideal .

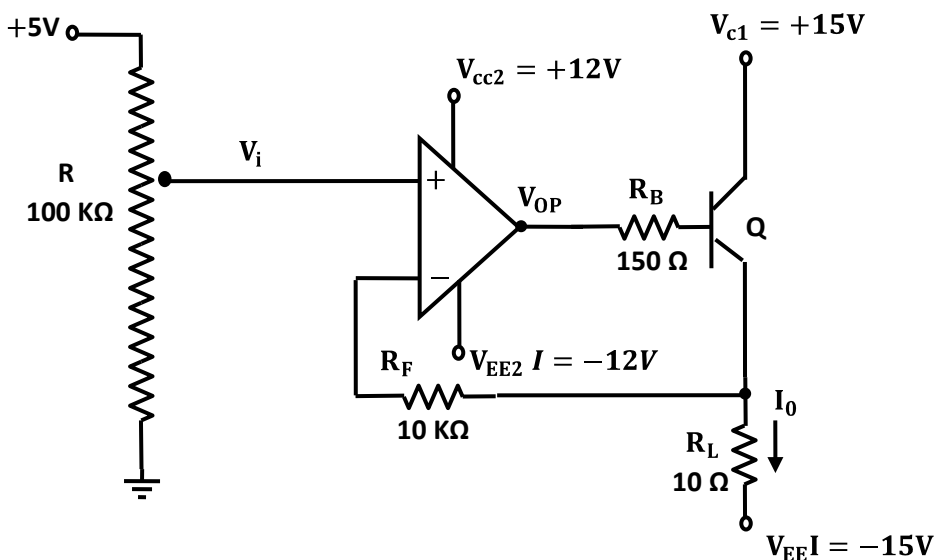

- (A) In which mode is the BJT operating (i.e. active, saturation or cut off) ? Justify your answer.  
 (B) Obtain an expression relating the output current  $I_0$  and  $V_{OP}$  if  $V_i = 2$  volt ( $V_{OP}$  : output of opamp)

(Assume  $\beta = 99$  and  $V_{BE} = 0.7$  V)

9. The inputs to a digital circuit shown in the figure is are the external signals A, B and C. ( $\bar{A}$ ,  $\bar{B}$  and  $\bar{C}$  are not available). The +5 V power supply (logic 1) and the ground (logic 0) are also available. The output of the circuit is  $X = \bar{A} B + \bar{A} \bar{B} \bar{C}$ .

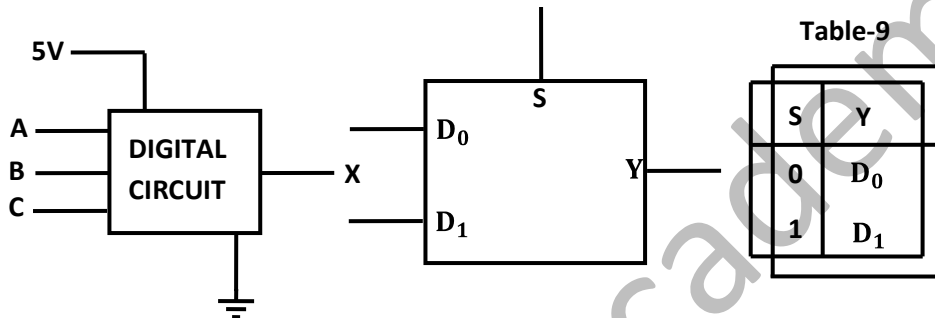

(A) Write down the output function in its canonical SOP and POS forms.

(B) Implement the circuit using only two 2:1 multiplexers shown in the figure where S is the data-select line, D<sub>0</sub> and D<sub>1</sub> are the input data lines and Y is the output line. The function table for the multiplexer is in given Table.

10. Each transistor in the figure is has dc current gain  $\beta_{dc} = 50$ , cut-in voltage  $V_{\gamma} = 0.65$  V and  $V_{BE}'_{sat} = 0.75$  V. The output voltage  $V_0$  for T<sub>2</sub> in saturation can be as high as 0.2 V. Assume 0.7 V drop across a conducting p-n junction. Determine?

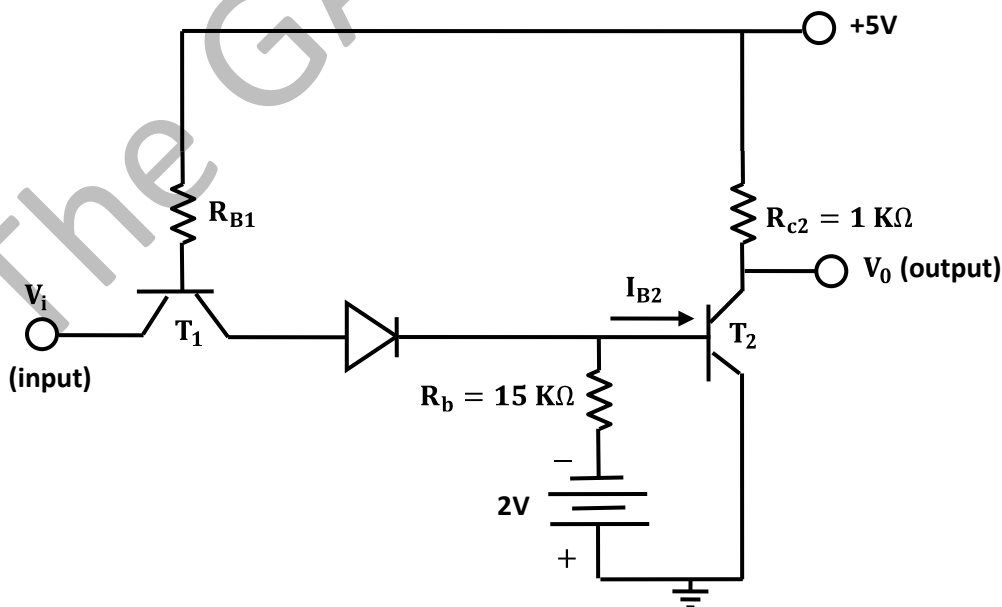

(A) the minimum value  $I_{B2}$  necessary to keep T<sub>2</sub> saturation.

(B) the maximum permissible value for the resistance  $R_{B1}$ .

(C) the worst-case high input (logic 1) and the worst-case low input (logic 0) for which T<sub>2</sub> will be either in saturation or in cut-off.

11. It is required to design a binary mod-5 synchronous counter using AB flip-flops such that the output  $Q_2 Q_1 Q_0$  change as 000  $\rightarrow$  001  $\rightarrow$  010..... and so on. The excitation table for the AB flip-flop is given in the table

A	B	$Q_{n+1}$
0	0	1
0	1	$\bar{Q}_n$
1	0	$Q_n$
1	1	0

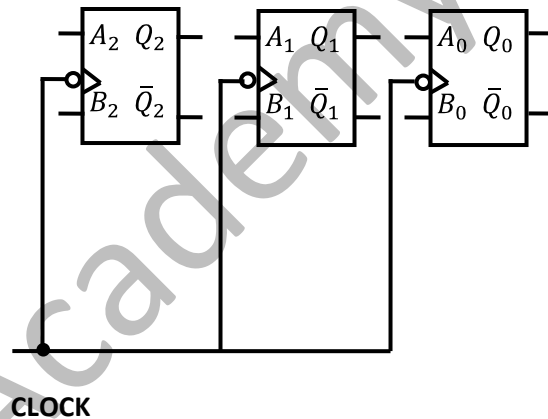

- (A) Write down the state table for the mod-5 counter.  
 (B) Obtain simplified SOP expressions for the inputs  $A_2$ ,  $B_2$ ,  $A_1$ ,  $B_1$ ,  $A_0$  and  $B_0$  in terms of  $Q_2$ ,  $Q_1$ ,  $Q_0$  and their complements.  
 (C) Hence, complete the circuit diagram for the mod-5 counter given in the figure using minimum number of 2-input NAND-gate only.

12. An 8085 microprocessor operating at 5 MHz clock frequency executes the following routine.

```
START :  MOVE    A, B
         OUT     55H
         DCR    B
         STA    FFF8H
         JMP    START
```

- (A) Determine the total number of machine cycles required to execute this routine till the JMP instruction is executed for the first time.  
 (B) Determine the time interval between two consecutive  $\overline{\text{MEMW}}$  signals.  
 (C) If the external logic controls the READY line so that three WAIT states are introduced in the I/O WRITE machine cycle, determine the time interval between two consecutive  $\overline{\text{MEMW}}$  signals.

13. A unity feedback system has the place transfer function  $G_p(s) = \frac{1}{(s+1)(2s+1)}$

- (A) Determine the frequency at which the plant has a phase lag of  $90^\circ$ .  
 (B) An integral controller with transfer function  $G_c(s) = \frac{k}{s}$  is placed in the feedforward path of the feedback system. Find the value of k such that the compensated system has an open-loop gain margin of 2.5  
 (C) Determine the steady state errors of the compensated system to unit-step and unit-ramp inputs.

14. The Nyquist plot of an all-pole second order open-loop system is shown in the figure is. Obtain the transfer function of the system.



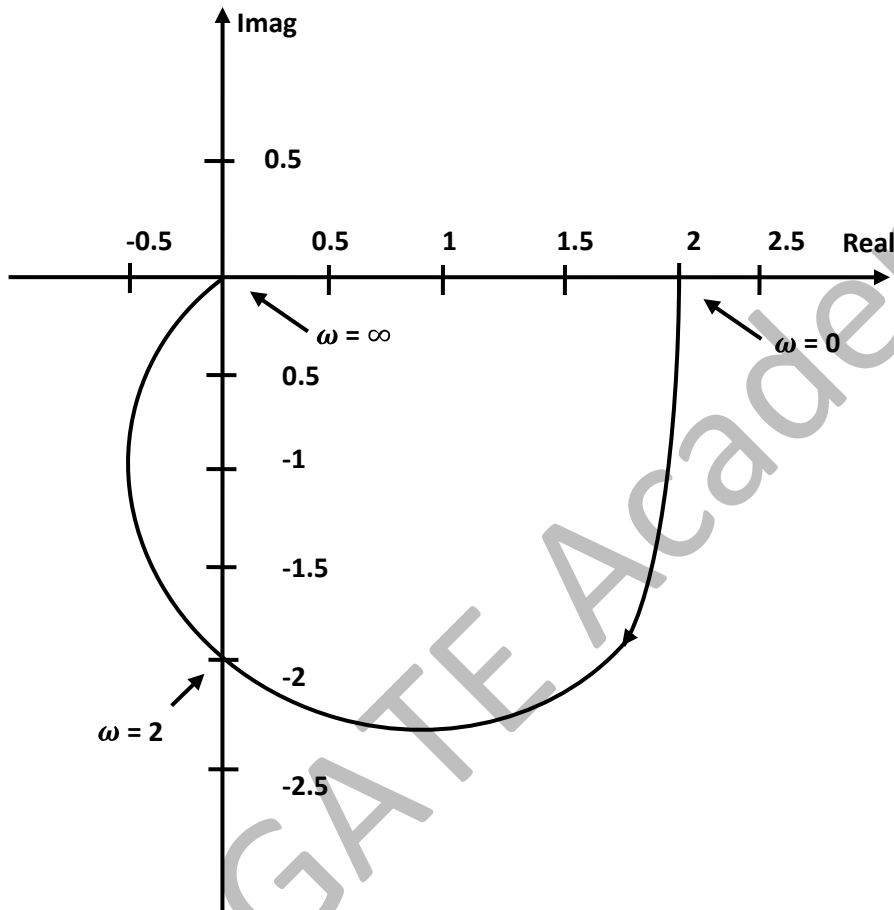

15. The block diagram of a linear time invariant system is given in the figure is

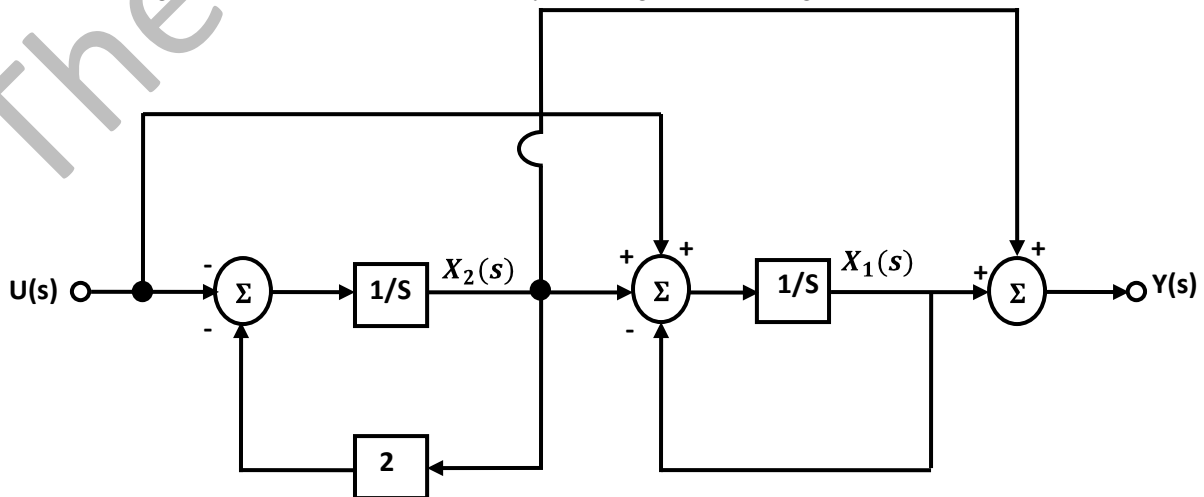

- (A) Write down the state variable equations for the system in matrix form assuming the state vector to be  $[x_1(t) \ x_2(t)]^T$   
 (B) Find out the state transition matrix.  
 (C) Determine  $y(t)$ ,  $t \geq 0$ , When the initial values of the state at time  $t = 0$  are  $x_1(0) = 1$ , and  $x_2(0) = 1$ .

16. A deterministic signal  $x(t) = \cos 2\pi t$  is passed through a differentiator as shown in the figure is

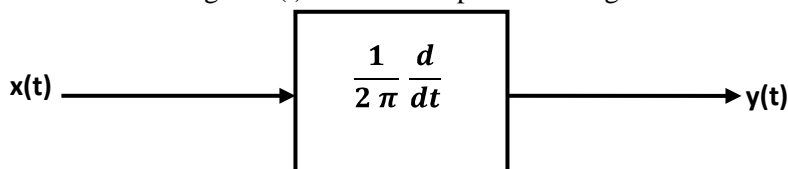

- (A) Determine the autocorrelation  $R_{xx}(T)$  and the power spectral density  $S_{xx}(f)$ .
- (B) Find the output power spectral density  $S_{yy}(f)$ .
- (C) Evaluate  $R_{xy}(0)$  and  $R_{xy}\left(\frac{1}{4}\right)$

17. A DSBSC modulated signal  $s(t) = 10 \cos(2\pi \times 10^6 t + \phi) m(t^-)$  is corrupted by an additive white Gaussian noise of power spectral density  $10^{-4}$  W/Hz. The message power spectral density  $S_{mm}(f)$  is as shown in the figure and  $\phi$  is uniformly distributed over the range 0 to  $2\pi$ .

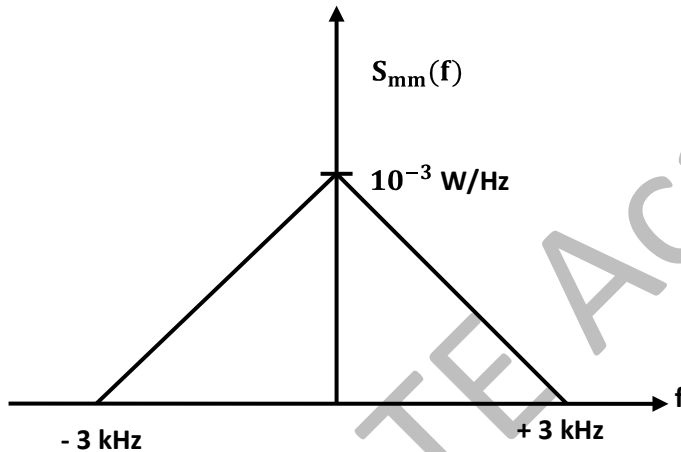

- (A) Express the signal autocorrelation function  $R_{ss}(T)$  in terms of the message autocorrelation function  $R_{mm}(T)$ . Clearly state the necessary assumptions.
  - (B) Determine the signal power spectral density  $S_{ss}(f)$ .
  - (C) Find the power of the modulated signal and the noise power in the transmission bandwidth.
18. A continuous-time signal with finite energy, band limited from 3 MHz to 5 MHz, is ideally sampled, encoded by a fixed length PCM coder and then transmitted over a digital channel of capacity 7 Mbps. The probability density function (pdf) at the output of the sampler is uniform over the range  $-2V$  to  $+2V$ .
- (A) Determine the minimum sampling rate necessary for perfect reconstruction.
  - (B) Determine the maximum SNR (in dB) that may be achieved.
19. A discrete memoryless source generates either 0 or 1 at rate of 160 Kbps; 0 is generated three times more frequently than 1. A coherent binary PSK modulator is employed to transmit these bits over a noisy channel. The received bits are detected in a correlator fed with the basis function of unit energy (for this binary PSK scheme) as the reference signal. The receiver makes a decision in favour of 1 if the correlator output is positive, else decides in favour of 0. If 0 and 1 are represented as  $-(6\sqrt{2} \cos 640\pi \times 10^3 t)V$  and  $+(6\sqrt{2} \cos 640\pi \times 10^3 t)V$  respectively, then
- (A) Determine the transmitted signal energy per bit.
  - (B) Determine the basis function of unit energy for this binary PSK scheme.
  - (C) Determine the probability that the receiver makes a decision in favour of 1 when the channel noise is characterized as zero-mean AWGN with power spectral density  $\frac{N_0}{2} = 3.125 \times 10^{-4}$  W/Hz
20. Transmission line transformation of a load  $Z_L$  to  $Z$  is given by
- $$Z = Z_0 \frac{Z_L + jZ_0 \tan(\beta l)}{Z_0 + jZ_L \tan(\beta l)}$$
- (A) Show that the above transformation implies that the impedance  $Z$  gets transformed to  $Z_L^*$  for real  $Z$ .
  - (B) What is the importance of the result derived in (a)?.
21. Consider a parallel plate waveguide with plate separation  $d$  as shown in the figure electric and magnetic fields for the TEM-mode are given by
- $$E_x = E_0 e^{-jkz + j\omega t}$$

$$H_y = \frac{E_0}{n} e^{-jkz + j\omega t}$$

Where  $k = \eta\omega\epsilon$

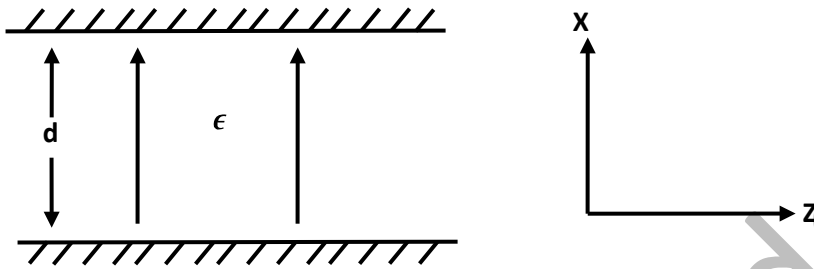

- (A) Determine the surface charge densities  $P_s$  on the plates at  $x = 0$  and  $x = d$   
 (B) Determine the surface current densities  $\vec{J}_s$  on the same plates.  
 (C) Prove that  $P_s$  and  $\vec{J}_s$  satisfy the current continuity condition.

22. Consider a linear array of two half-wave dipoles A and B as shown in the figure is. The dipoles are  $\frac{\lambda}{4}$  apart and are excited in such a way that the current on element B lags that on element A by  $90^\circ$  in phase.

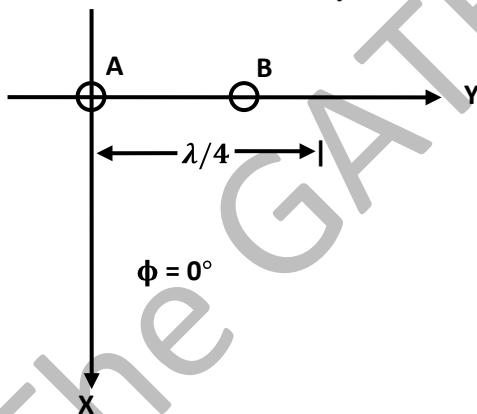

- (A) Obtain the expression for the radiation pattern for  $E_\theta$  in the XY plane (i.e.,  $\theta = 90^\circ$ )  
 (B) Sketch the radiation pattern obtained in (a).