



Control Systems

Topics Covered

**Block diagram reduction
technique**

Figure 2.14

Second-order feedback control system

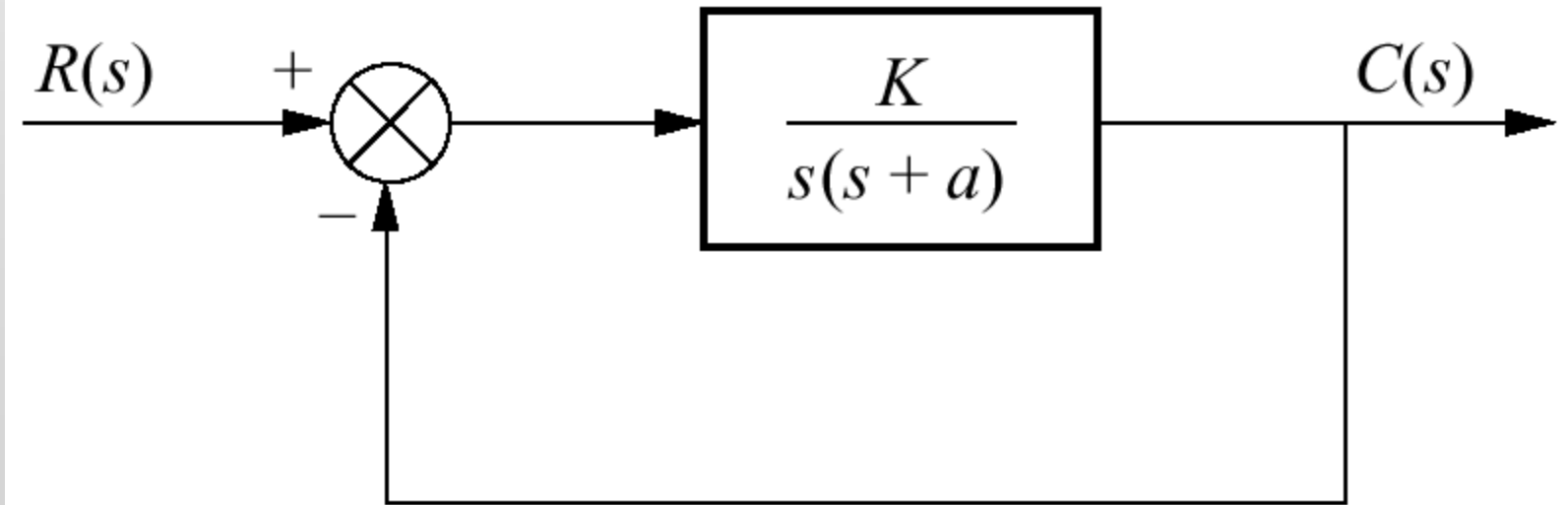

Figure 2.15

Feedback system

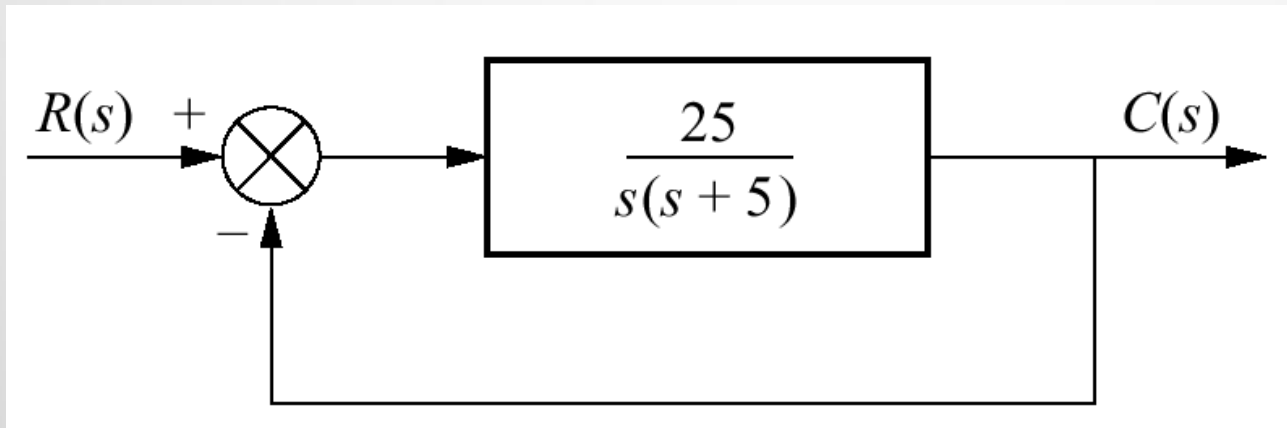

Figure 2.16

Feedback system

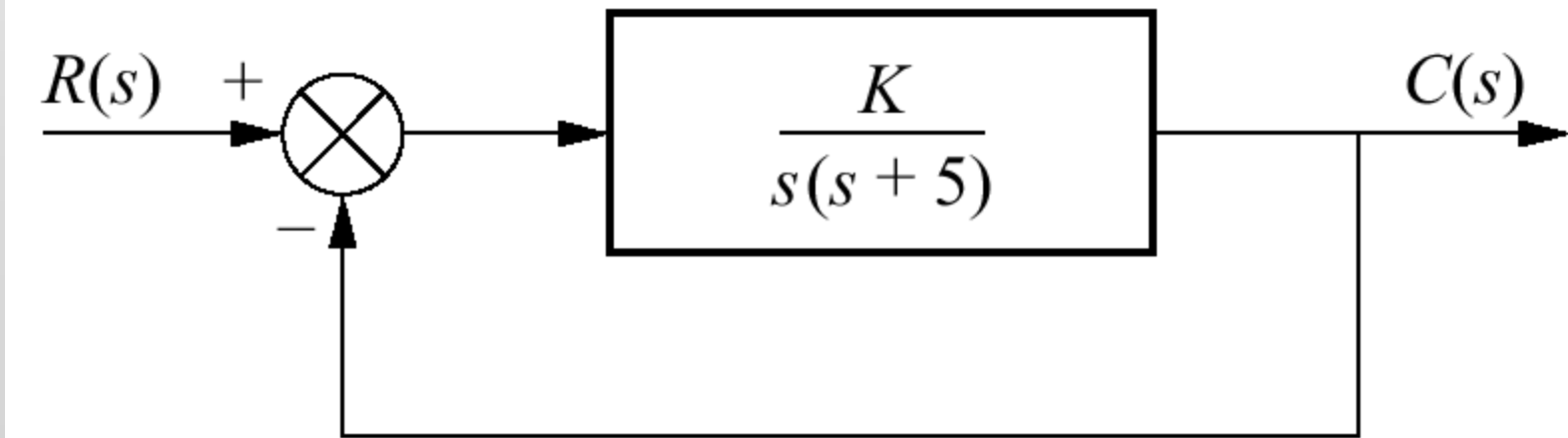

Figure 5.34
Alvin, a manned
submersible,
explored the
wreckage of
the *Titanic* with
a tethered robot,
Jason Junior.

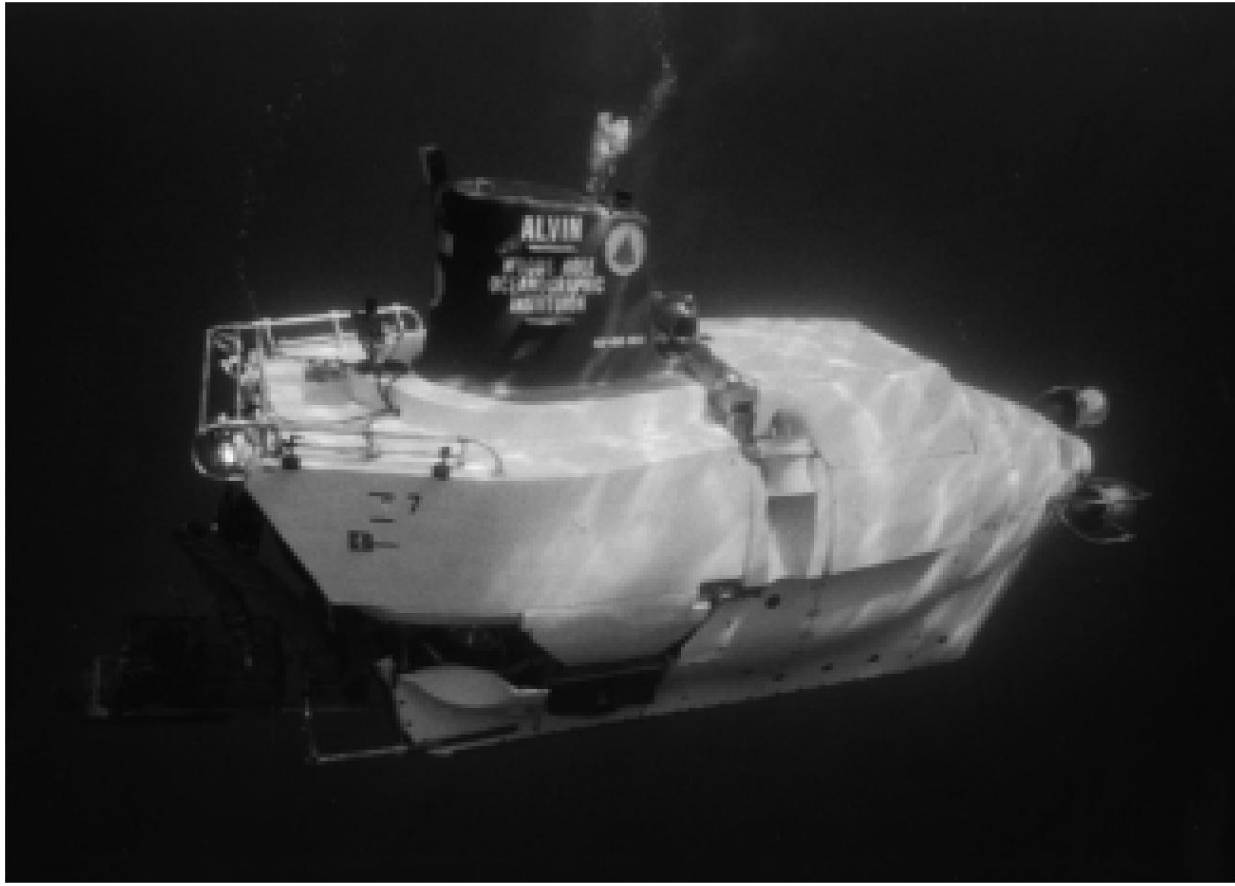

Figure 5.35

Block diagram reduction for the antenna azimuth position control system:

- a. original;
- b. pushing input potentiometer to the right past the summing junction;
- c. showing equivalent forward transfer function;
- d. final closed-loop transfer function

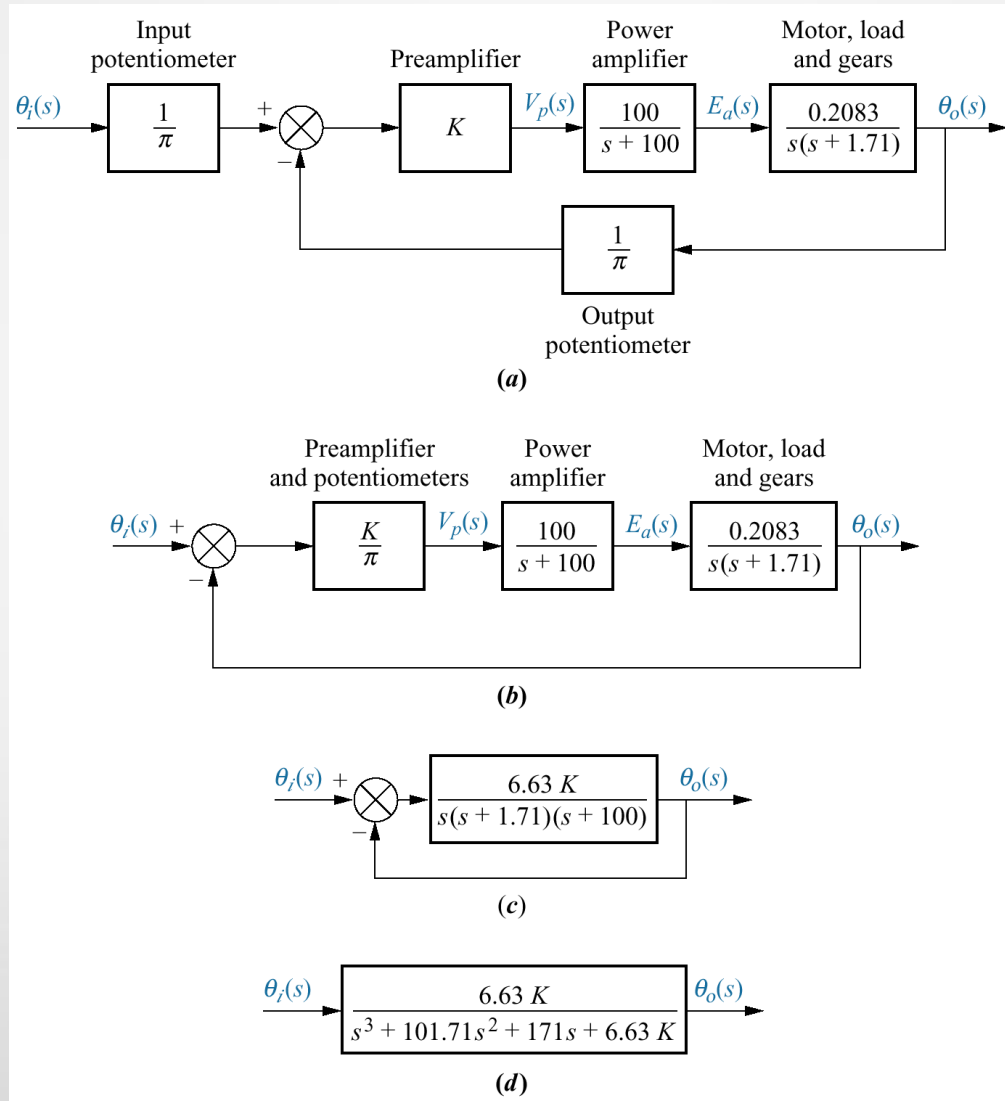

Figure P5.3

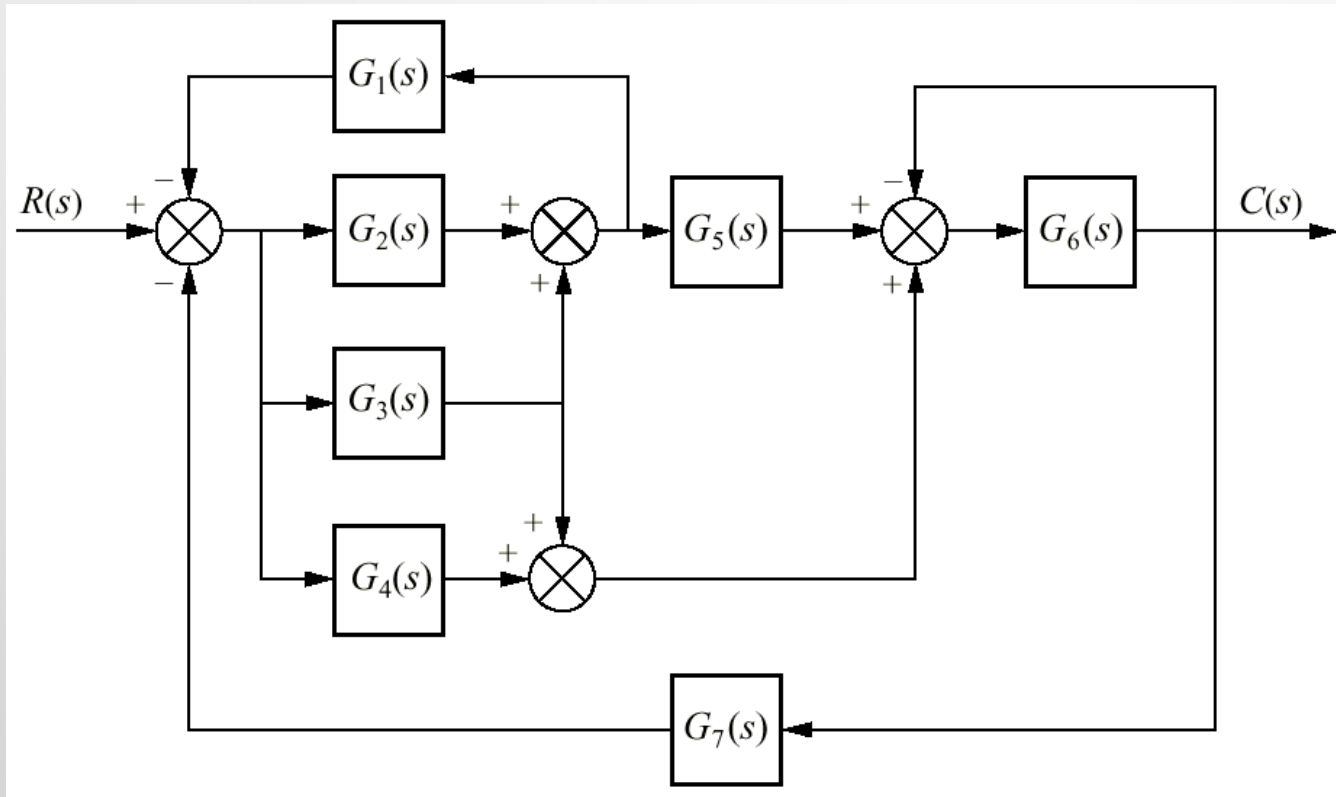

Figure P5.4

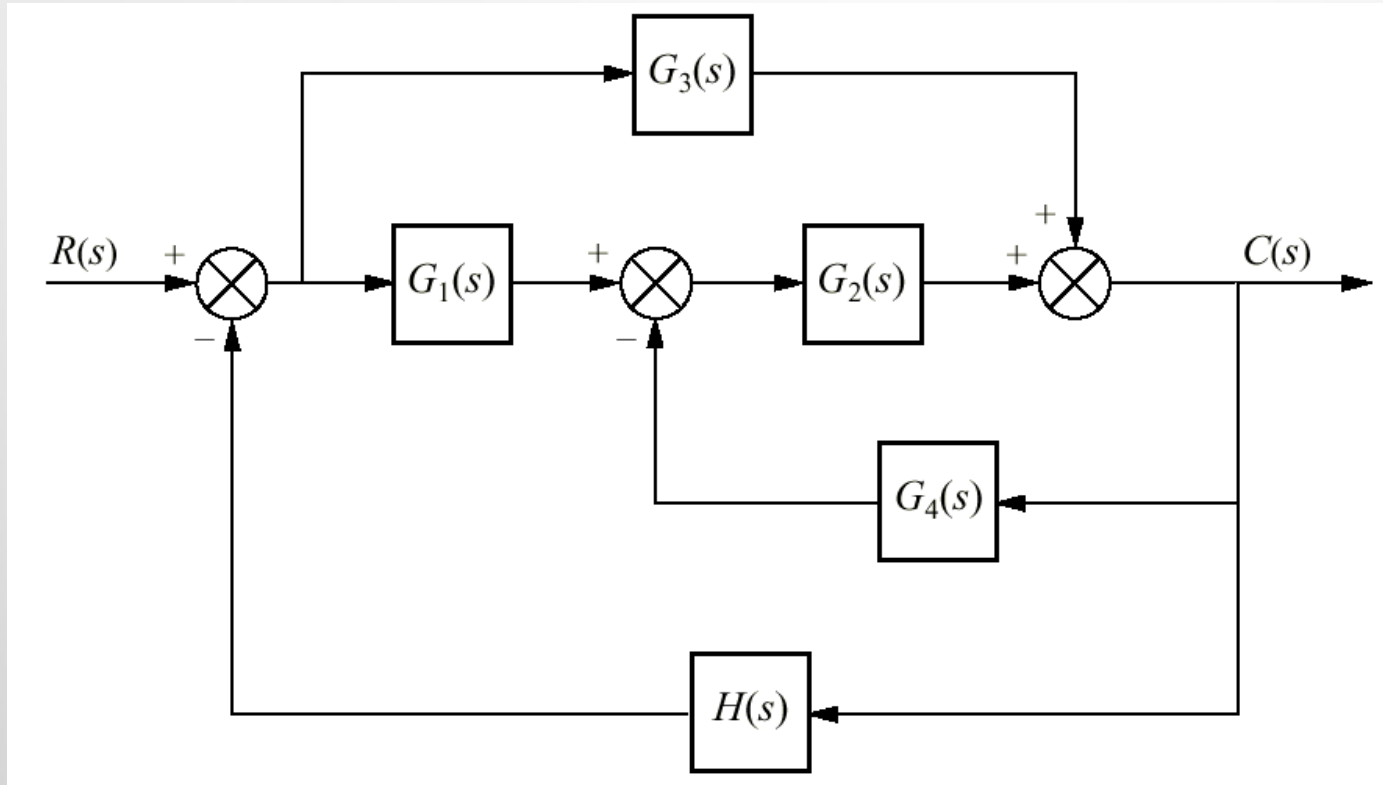

Figure P5.5

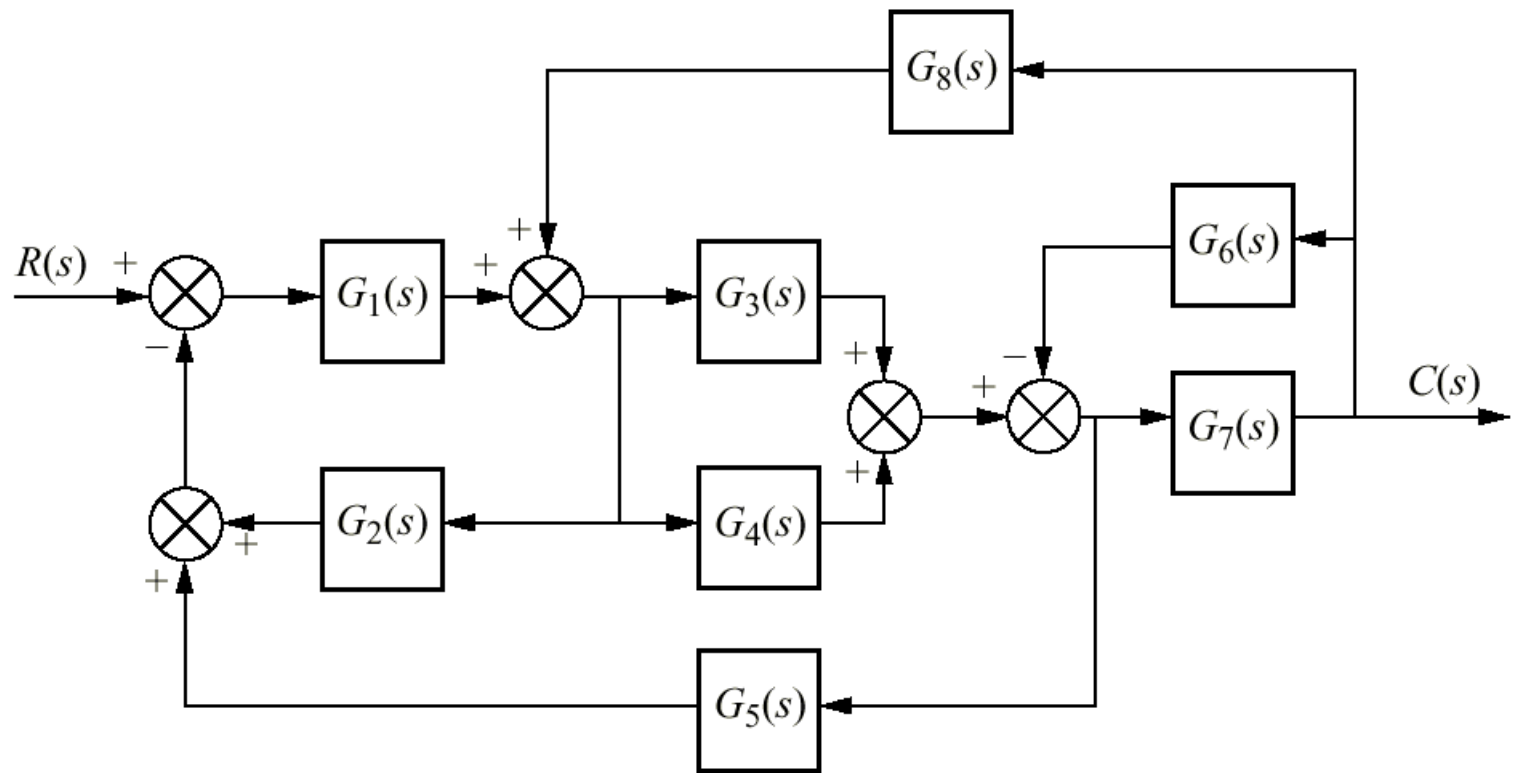

Figure P5.6

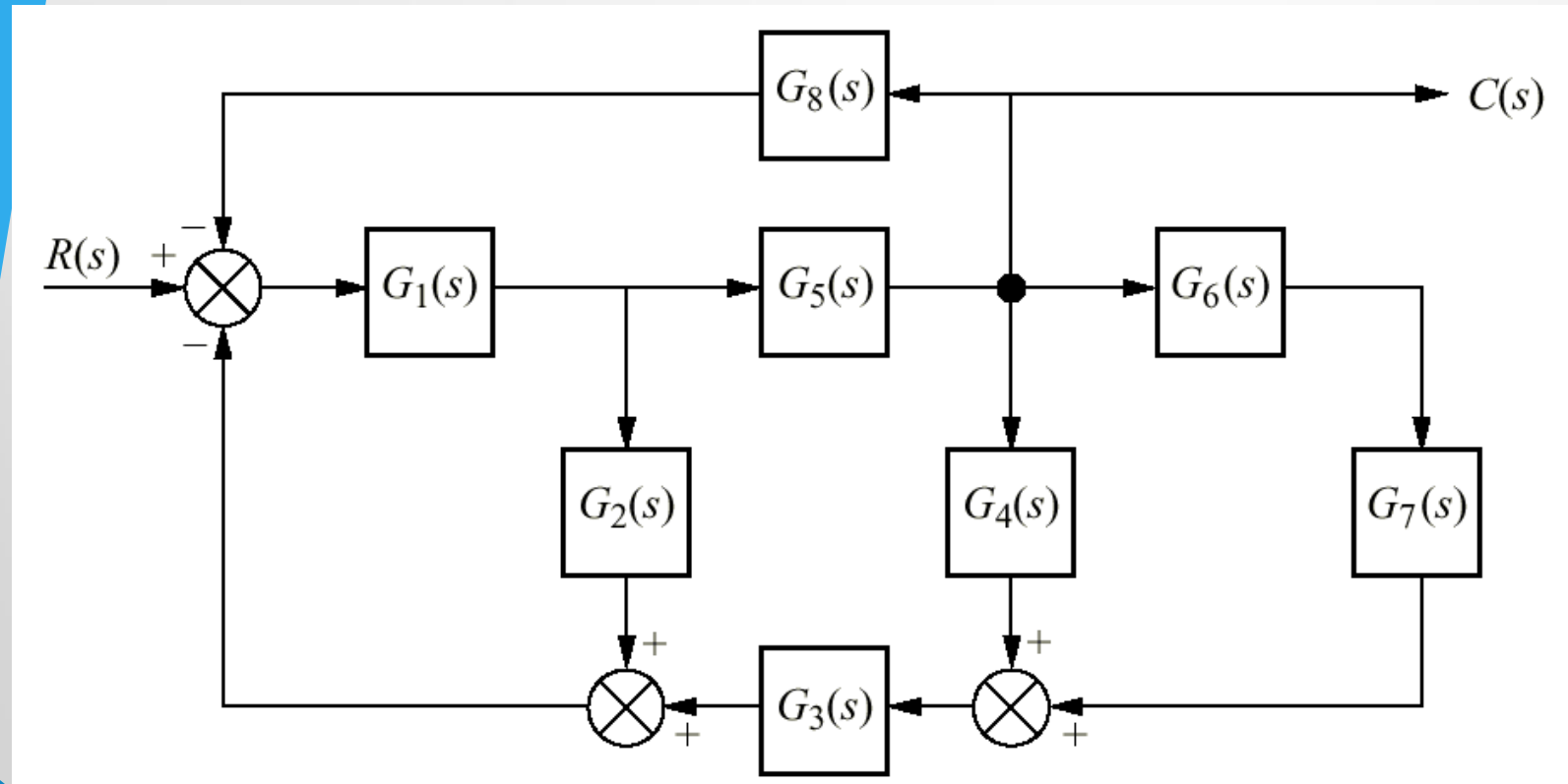

Figure P5.7

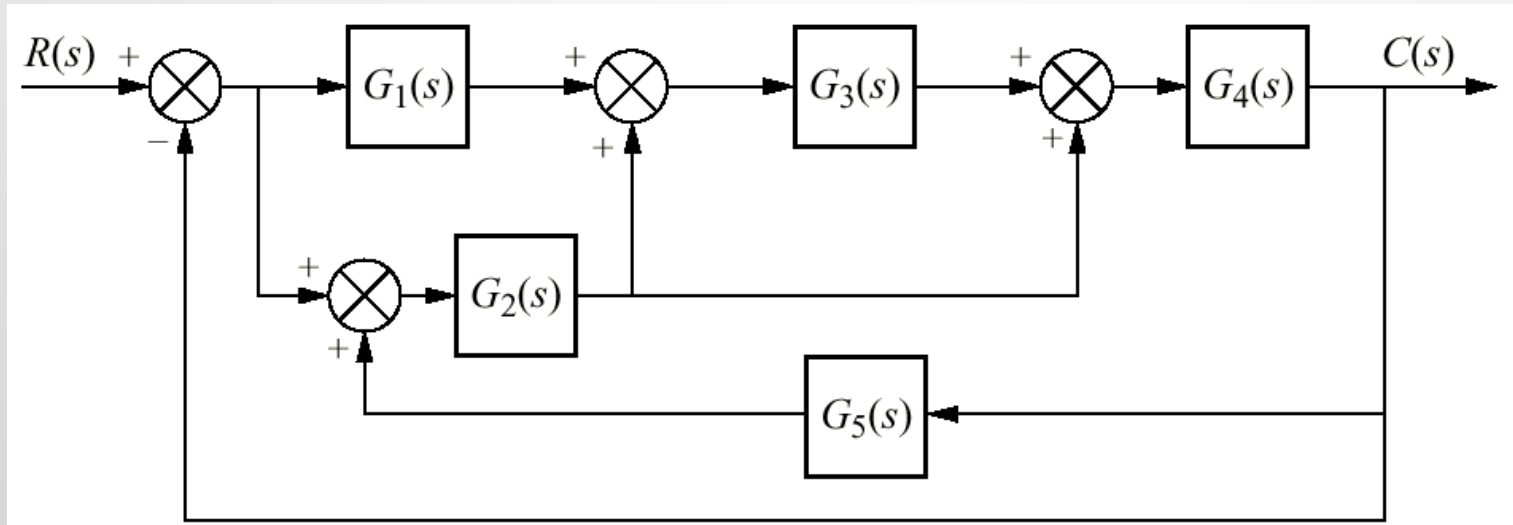

Figure P5.8

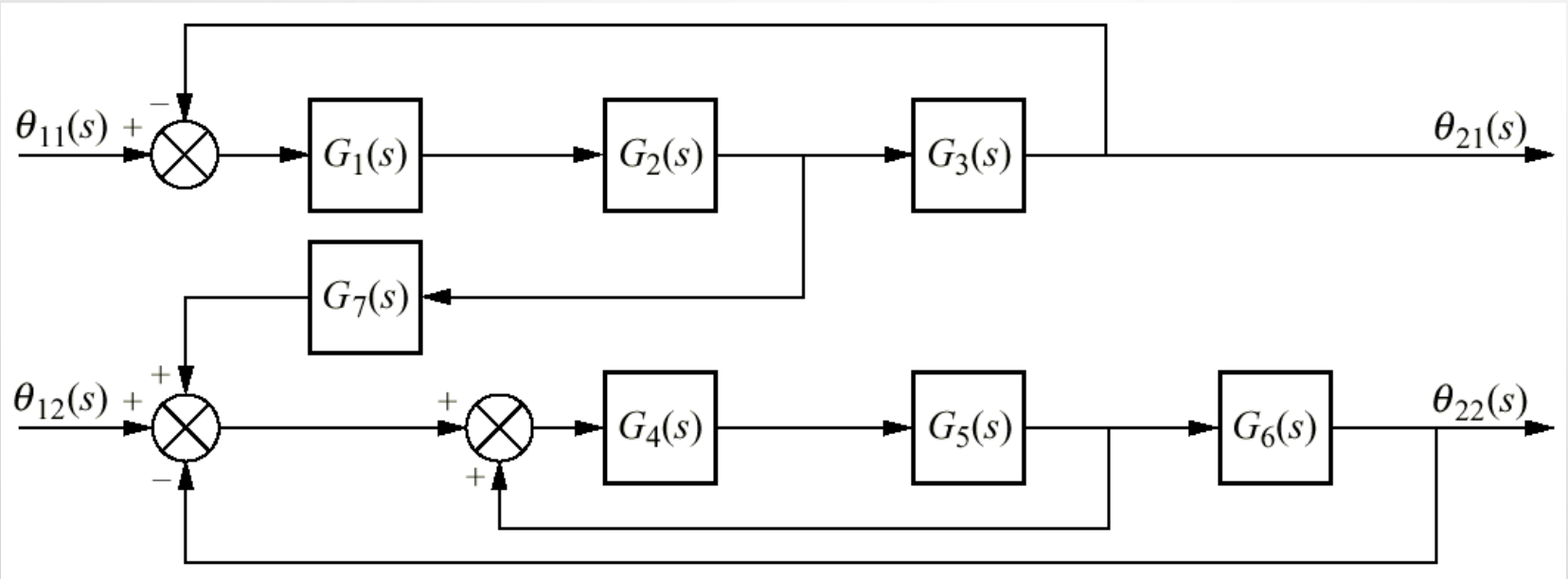

Figure P5.9

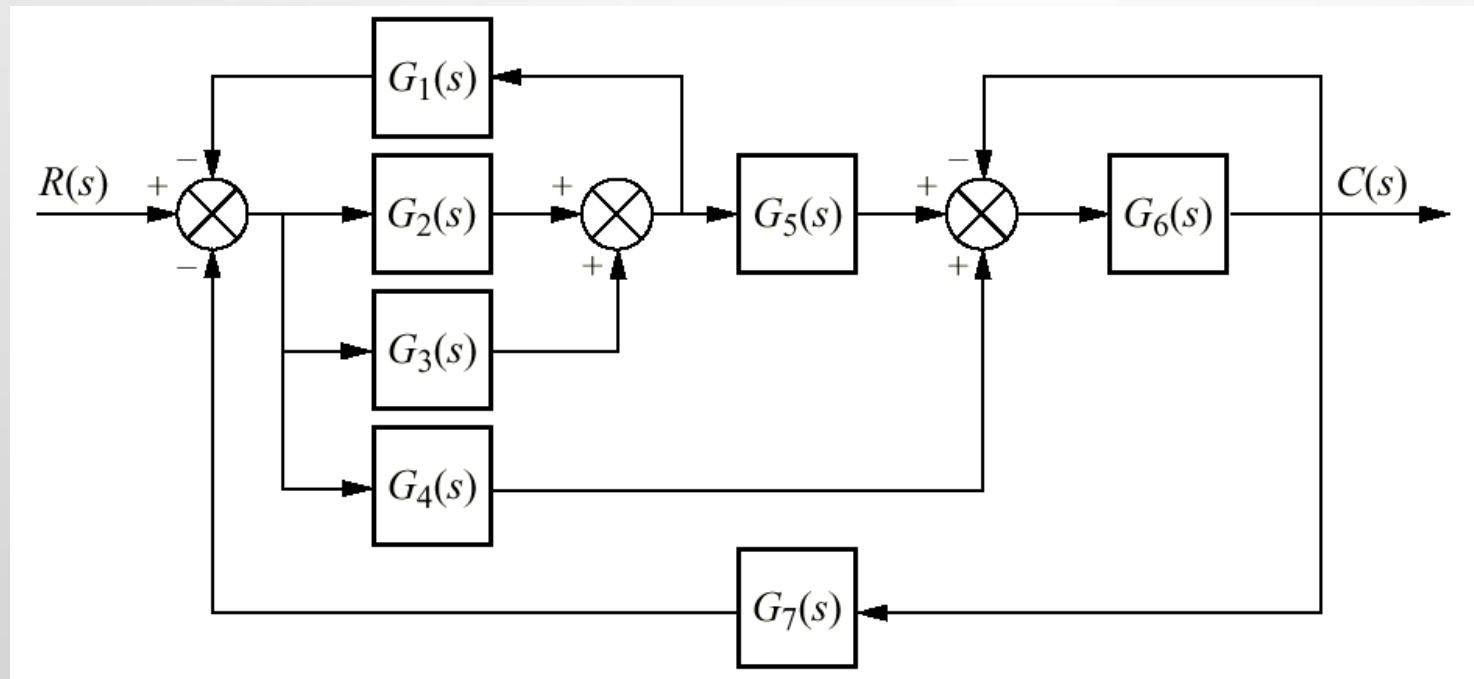

Figure P5.10

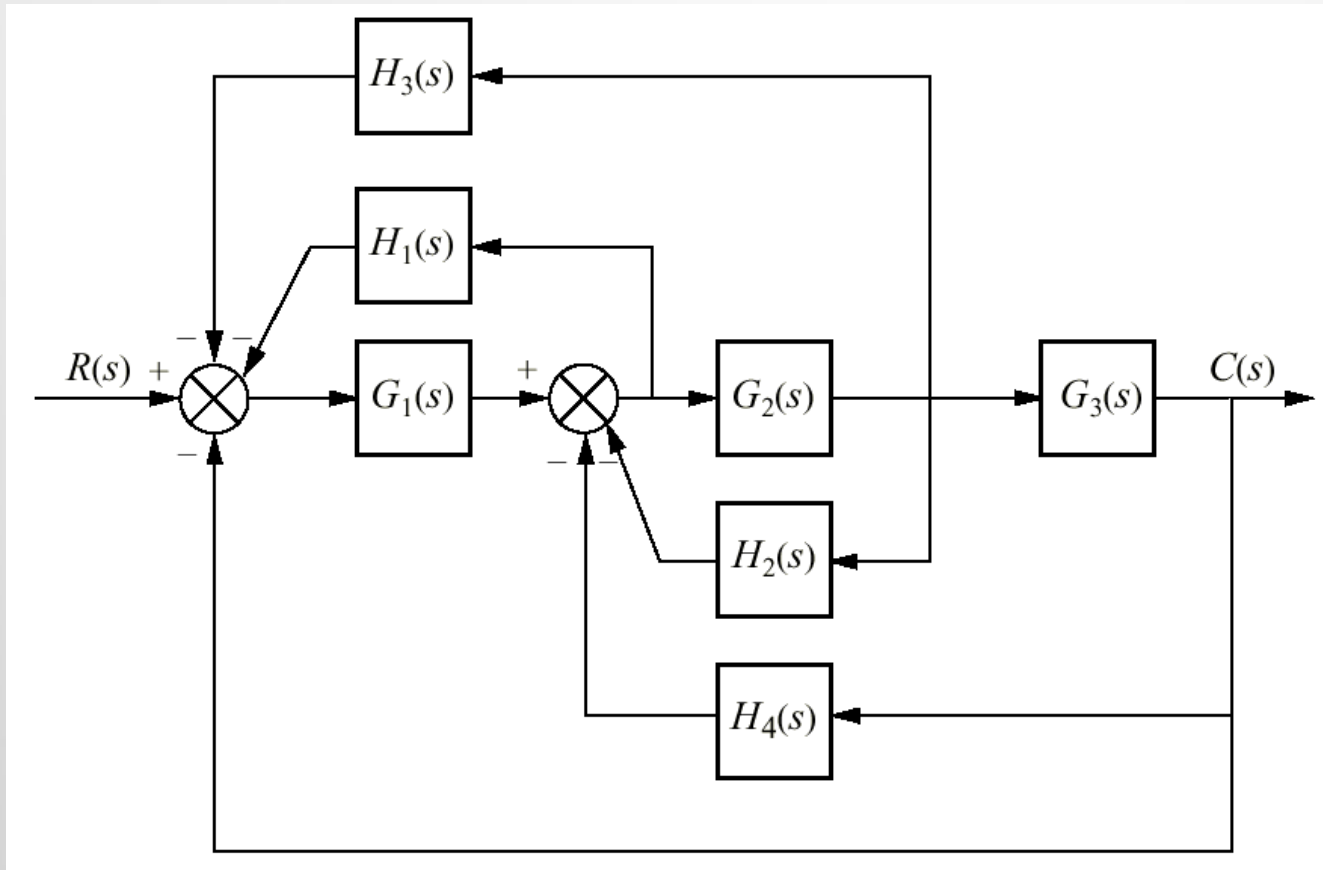

Figure P5.16

