



# Lecture 5



# **Topics Covered**

**Mathematical Modelling**

# Chapter 2 mathematical models of systems

## 2.1 Introduction

### 2.1.1 Why ?

- 1) Easy to discuss the full possible types of the control systems —only in terms of the system’s “mathematical characteristics”.
- 2) The basis of analyzing or designing the control systems.

### 2.1.2 What is ?

Mathematical models of systems — the mathematical relationships between the system’s variables.

### 2.1.3 How get ?

- 1) theoretical approaches
- 2) experimental approaches
- 3) discrimination learning

# Chapter 2 mathematical models of systems

## 2.1.4 types

- 1) Differential equations
- 2) Transfer function
- 3) Block diagram、 signal flow graph
- 4) State variables

## 2.2 The input-output description of the physical systems — differential equations

The input-output description—description of the mathematical relationship between the output variable and the input variable of physical systems.

### 2.2.1 Examples

# Chapter 2 mathematical models of systems

## Example 2.1 : A passive circuit

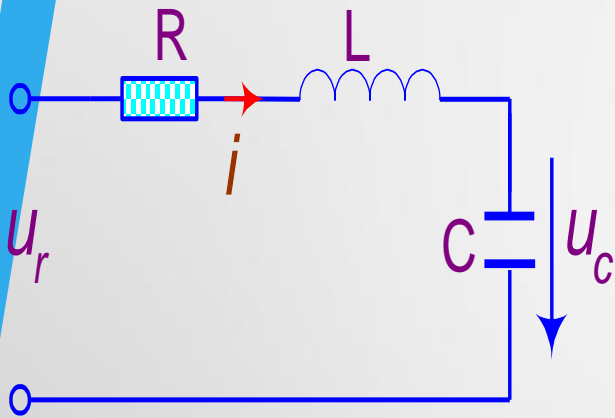

*define: input*  $\rightarrow u_r$     *output*  $\rightarrow u_c$   
*we have :*

$$Ri + L \frac{di}{dt} + u_c = u_r \quad i = C \frac{du_c}{dt}$$

$\Downarrow$

$$LC \frac{d^2 u_c}{dt^2} + RC \frac{du_c}{dt} + u_c = u_r$$

*make :*  $RC = T_1 \quad \frac{L}{R} = T_2 \Rightarrow T_1 T_2 \frac{d^2 u_c}{dt^2} + T_1 \frac{du_c}{dt} + u_c = u_r$

# Chapter 2 mathematical models of systems

## Example 2.2 : A mechanism

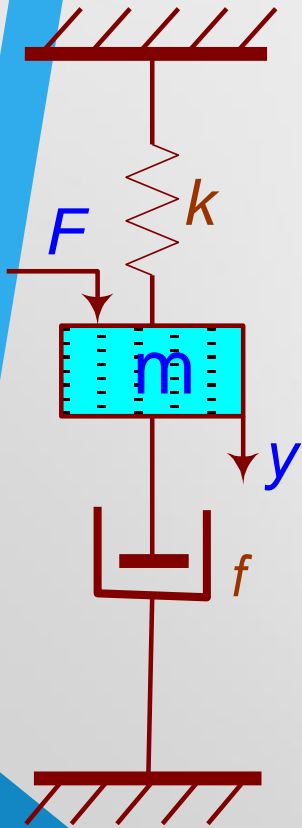

*Define: input  $\rightarrow F$ , output  $\rightarrow y$ . We have:*

$$F - ky - f \frac{dy}{dt} = m \frac{d^2 y}{dt^2}$$

$\Downarrow$

$$m \frac{d^2 y}{dt^2} + f \frac{dy}{dt} + ky = F$$

*If we make :  $\frac{f}{k} = T_1$ ,  $\frac{m}{f} = T_2$*

*we have :  $T_1 T_2 \frac{d^2 y}{dt^2} + T_1 \frac{dy}{dt} + y = \frac{1}{k} F$*

*Compare with example 2.1:  $u_c \rightarrow y, u_r \rightarrow F$  --- analogous systems*

# Chapter 2 mathematical models of systems

## Example 2.4 : A DC motor

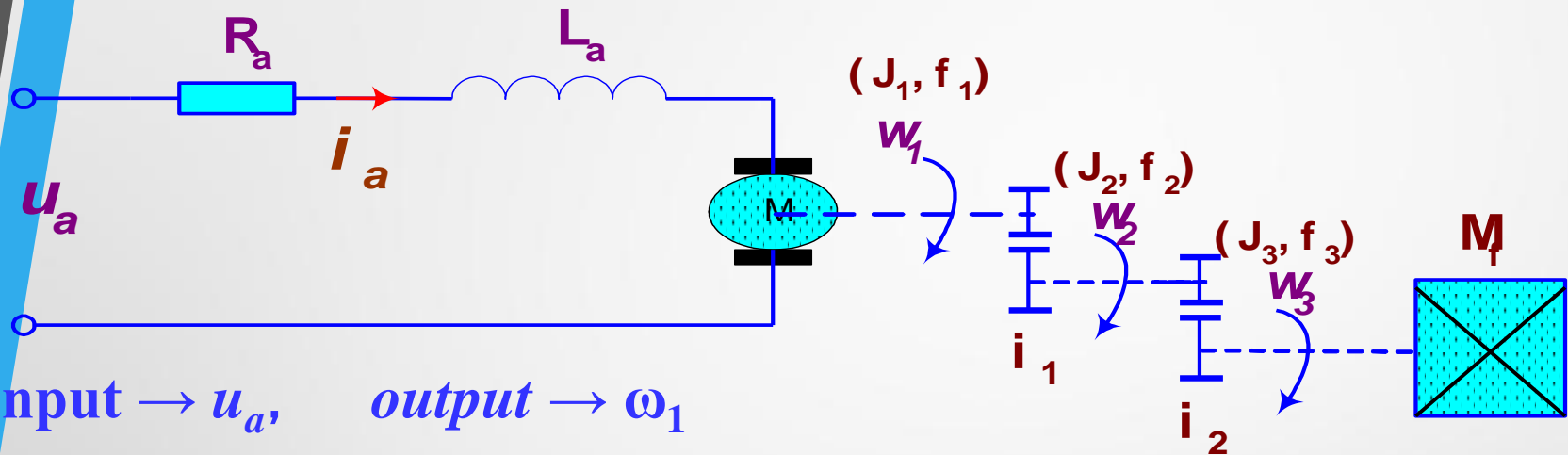

Input  $\rightarrow u_a$ , output  $\rightarrow \omega_1$

$$L_a \frac{di_a}{dt} + R_a i_a + E_a = u_a \dots (1)$$

$$M = C_m i_a \dots (2)$$

$$E_a = C_e \omega_1 \dots (3)$$

$$M - \bar{M} = \bar{J} \frac{d\omega_1}{dt} + \bar{f} \omega_1 \dots (4)$$

(4)  $\rightarrow$  (2)  $\rightarrow$  (1) and (3)  $\rightarrow$  (1) :

$$\frac{L_a \bar{J}}{C_e C_m} \ddot{\omega}_1 + \left( \frac{L_a \bar{f}}{C_e C_m} + \frac{R_a \bar{J}}{C_e C_m} \right) \dot{\omega}_1 + \left( \frac{R_a \bar{f}}{C_e C_m} + 1 \right) \omega_1$$

$$= \frac{1}{C_e} u_a - \frac{L_a}{C_e C_m} \dot{\bar{M}} - \frac{R_a}{C_e C_m} \bar{M}$$

# Chapter 2 mathematical models of systems

$$\bar{J} = J_1 + \frac{J_2}{i_1^2} + \frac{J_3}{i_1^2 i_2^2} \dots \dots \text{equivalent moment of inertia}$$

here :  $\bar{f} = f_1 + \frac{f_2}{i_1^2} + \frac{f_3}{i_1^2 i_2^2} \dots \dots \text{equivalent friction coefficient}$

$$\bar{M} = \frac{M_f}{i_1 i_2} \dots \dots \dots \text{equivalent torque}$$

(can be derived from :  $\omega_1 = i_1 \omega_2 = i_1 i_2 \omega_3$ )

Make:  $T_e = \frac{L_a}{R_a} \dots \dots \dots \text{electric - magnetic time - constant}$

$$T_m = \frac{R_a \bar{J}}{C_e C_m} \dots \dots \dots \text{mechanical - electric time - constant}$$

$$T_f = \frac{R_a \bar{f}}{C_e C_m} \dots \dots \dots \text{friction - electric time - constant}$$



# Chapter 2 mathematical models of systems

the differential equation description of the DC motor is:

$$\begin{aligned} T_e T_m \ddot{\omega}_1 + (T_e T_f + T_m) \dot{\omega}_1 + (T_f + 1) \omega_1 \\ = \frac{1}{C_e} u_a - \frac{1}{J} (T_e T_m \dot{M} + T_m \overline{M}) \end{aligned}$$

Assume the motor idle:  $M_f = 0$ , and neglect the friction:  $f = 0$ , we have:

$$T_e T_m \frac{d^2 \omega}{dt^2} + T_m \frac{d\omega}{dt} + \omega = \frac{1}{C_e} u_a$$

Compare with example 2.1 and example 2.2:

$$u_c \Leftrightarrow y \Leftrightarrow \omega; \quad u_r \Leftrightarrow F \Leftrightarrow u_a \text{ ----Analogous systems}$$

# Chapter 2 mathematical models of systems

## Example 2.5: A DC-Motor control system

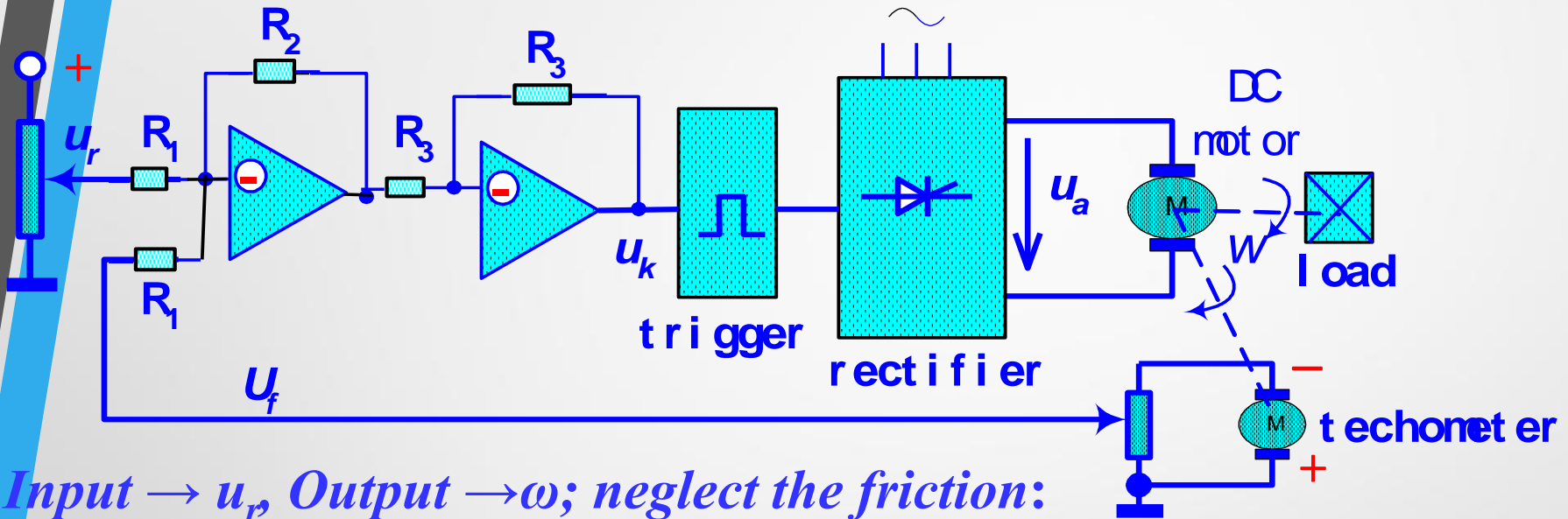

$$u_k = \frac{R_2}{R_1} (u_r - u_f) = k_1 (u_r - u_f) \dots \dots \dots (1)$$

$$u_f = \alpha \omega \dots \dots \dots (2)$$

$$u_a = k_2 u_k \dots \dots \dots (3)$$

$$T_e T_m \frac{d^2 \omega}{dt^2} + T_m \frac{d\omega}{dt} + \omega = \frac{1}{C_e} u_a - \frac{1}{J} (T_e T_m \dot{\bar{M}} + T_m \bar{M}) \dots \dots (4)$$

# Chapter 2 mathematical models of systems

(2)  $\rightarrow$  (1)  $\rightarrow$  (3)  $\rightarrow$  (4) , we have :

$$T_e T_m \frac{d^2 \omega}{dt^2} + T_m \frac{d\omega}{dt} + (1 + k_1 k_2 \alpha \frac{1}{C_e}) \omega = k_1 k_2 \frac{1}{C_e} u_r - \frac{T_m}{J} (T_e \dot{\bar{M}} + \bar{M})$$

## 2.2.2 steps to obtain the input-output description (differential equation) of control systems

- 1) Identify the output and input variables of the control systems.
- 2) Write the differential equations of each system's component in terms of the physical laws of the components.
  - \* necessary assumption and neglect.
  - \* proper approximation.
- 3) dispel the intermediate(across) variables to get the input-output description which only contains the output and input variables.

# Chapter 2 mathematical models of systems

4) Formalize the input-output equation to be the “standard” form:

Input variable — on the right of the input-output equation .

Output variable — on the left of the input-output equation.

Writing the polynomial—according to the falling-power order.

## 2.2.3 General form of the input-output equation of the linear control systems

—A  $n$ th-order differential equation:

Suppose:  $input \rightarrow r$  ,  $output \rightarrow y$

$$y^{(n)} + a_1 y^{(n-1)} + a_2 y^{(n-2)} + \dots + a_{n-1} y^{(1)} + a_n y$$

$$= b_0 r^{(m)} + b_1 r^{(m-1)} + b_2 r^{(m-2)} + \dots + b_{m-1} r^{(1)} + b_m r \dots \dots n \geq m$$

# Chapter 2 mathematical models of systems

## 2.4 Transfer function

Another form of the input-output(external) description of control systems, different from the differential equations.

### 2.4.1 definition

**Transfer function:** *The ratio of the Laplace transform of the output variable to the Laplace transform of the input variable with all initial condition assumed to be zero and for the linear systems, that is:*

# Chapter 2 mathematical models of systems

$$G(s) = \frac{C(s)}{R(s)}$$

$C(s)$  — Laplace transform of the output variable

$R(s)$  — Laplace transform of the input variable

$G(s)$  — transfer function

## Notes:

- \* Only for the linear and stationary (constant parameter) systems.
- \* Zero initial conditions.
- \* Dependent on the configuration and coefficients of the systems, independent on the input and output variables.

## 2.4.2 How to obtain the transfer function of a system

1) If the impulse response  $g(t)$  is known

# Chapter 2 mathematical models of systems

**We have:**  $G(s) = L[g(t)]$

**Because:**  $G(s) = \frac{C(s)}{R(s)}$ , if  $r(t) = \delta(t) \Rightarrow R(s) = 1$

**Then:**  $G(s) = C(s) = L[g(t)]$

**Example 2.8 :**  $g(t) = 5 - 3e^{-2t} \Rightarrow G(s) = \frac{5}{s} - \frac{3}{s+2} = \frac{2(s+5)}{s(s+2)}$

**2) If the output response  $c(t)$  and the input  $r(t)$  are known**

**We have:**  $G(s) = \frac{L[c(t)]}{L[r(t)]}$

# Chapter 2 mathematical models of systems

**Example 2.9:**  $r(t) = 1(t) \Rightarrow R(s) = \frac{1}{s}$  .....Unit step function

$$c(t) = 1 - e^{-3t} \Rightarrow C(s) = \frac{1}{s} - \frac{1}{s+3} = \frac{3}{s(s+3)}$$

.....Unit step response

Then:

$$G(s) = \frac{C(s)}{R(s)} = \frac{3/s(s+3)}{1/s} = \frac{3}{s+3}$$

### 3) If the input-output differential equation is known

- Assume: zero initial conditions;
- Make: Laplace transform of the differential equation;
- Deduce:  $G(s)=C(s)/R(s)$ .



# Chapter 2 mathematical models of systems

**Example 2.10:**

$$2\ddot{c}(t) + 3\dot{c}(t) + 4c(t) = 5\dot{r}(t) + 6r(t)$$

$\Downarrow$

$$2s^2C(s) + 3sC(s) + 4C(s) = 5sR(s) + 6R(s)$$

$\Downarrow$

$$G(s) = \frac{C(s)}{R(s)} = \frac{5s + 6}{2s^2 + 3s + 4}$$

## 4) For a circuit

- \* Transform a circuit into a operator circuit.
- \* Deduce the  $C(s)/R(s)$  in terms of the circuits theory.

# Chapter 2 mathematical models of systems

**Example 2.11:** For a electric circuit:

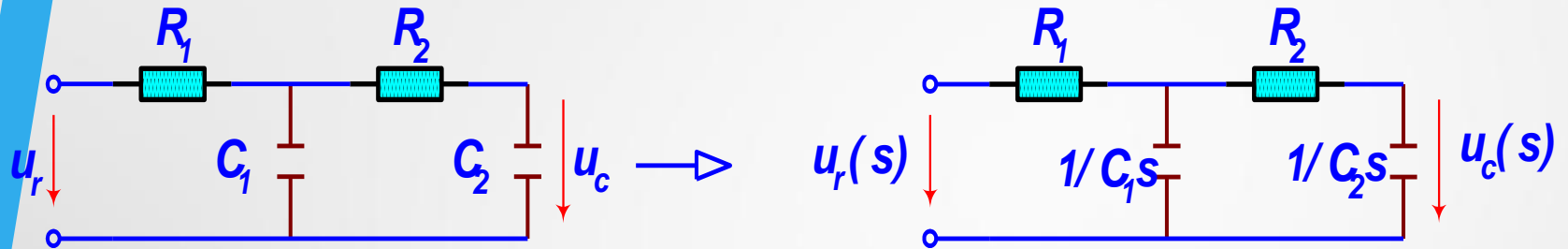

$$U_c(s) = \frac{\frac{1}{sC_1} \parallel (R_2 + \frac{1}{sC_2})}{R_1 + \frac{1}{sC_1} \parallel (R_2 + \frac{1}{sC_2})} \cdot U_r(s) \cdot \frac{1}{sC_2} \cdot \frac{1}{R_2 + \frac{1}{sC_2}}$$

$$= \frac{1}{T_1 T_2 s^2 + (T_1 + T_2 + T_{12})s + 1} \cdot U_r(s)$$

$$G(s) = \frac{U_c(s)}{U_r(s)} = \frac{1}{T_1 T_2 s^2 + (T_1 + T_2 + T_{12})s + 1}$$

here :  $T_1 = R_1 C_1$ ;  $T_2 = R_2 C_2$ ;  $T_{12} = R_1 C_2$

# Chapter 2 mathematical models of systems

Example 2.12: For a op-amp circuit

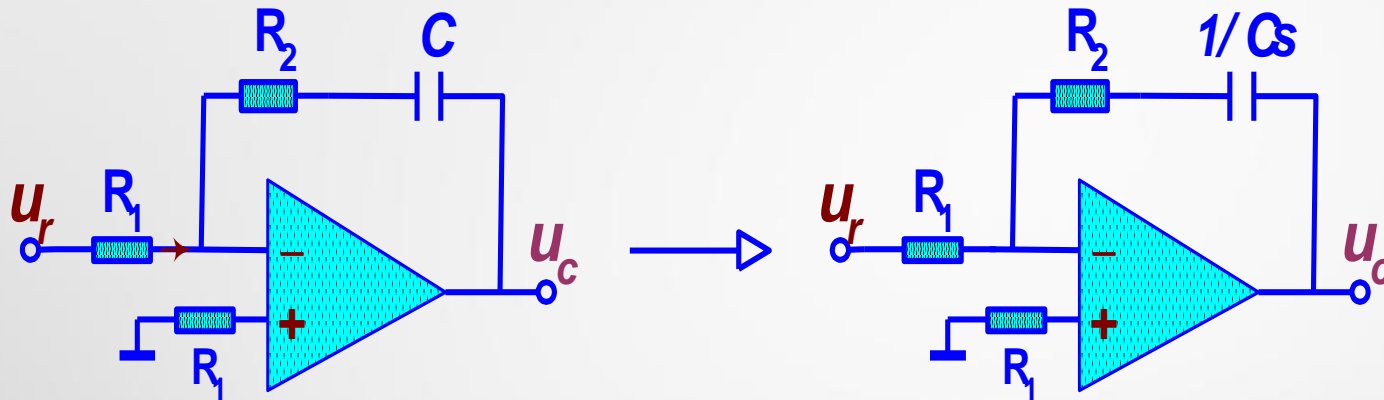

$$G(s) = \frac{U_c(s)}{U_r(s)} = -\frac{R_2 + \frac{1}{sC}}{R_1} = -\frac{R_2Cs + 1}{R_1Cs}$$
$$= -k\left(1 + \frac{1}{\tau s}\right) \dots \dots \dots \text{PI-Controller}$$

here :  $k = \frac{R_2}{R_1}$  ;  $\tau = R_2C$  .....Integral time constant

# Chapter 2 mathematical models of systems

## 5) For a control system

- Write the differential equations of the control system;
- Make Laplace transformation, assume zero initial conditions, transform the differential equations into the relevant algebraic equations;
- Deduce:  $G(s)=C(s)/R(s)$ .

## Example 2.13 the DC-Motor control system in Example 2.5

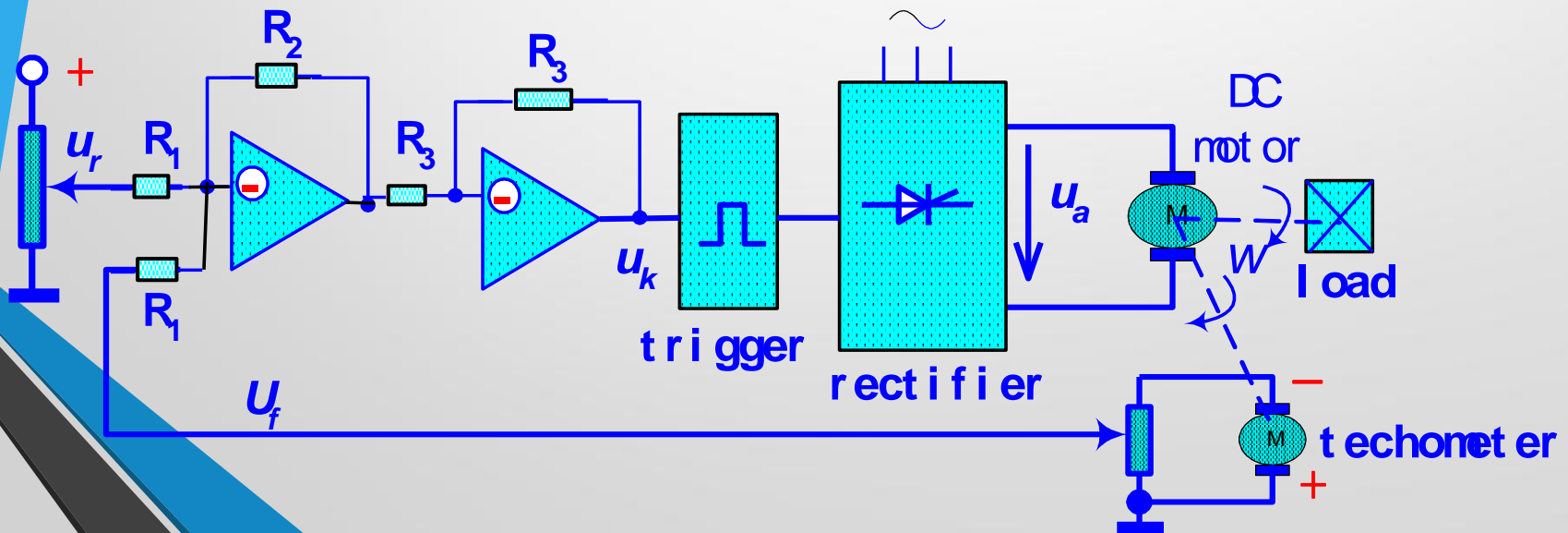

# Chapter 2 mathematical models of systems

In **Example 2.5**, we have written down the differential equations as:

$$u_k = \frac{R_2}{R_1} (u_r - u_f) = k_1 (u_r - u_f) \dots \dots \dots (1)$$

$$u_f = \alpha \omega \dots \dots \dots (2)$$

$$u_a = k_2 u_k \dots \dots \dots (3)$$

$$T_e T_m \frac{d^2 \omega}{dt^2} + T_m \frac{d\omega}{dt} + \omega = \frac{1}{C_e} u_a - \frac{T_m}{J} (T_e \dot{\bar{M}} + \bar{M}) \dots \dots \dots (4)$$

Make Laplace transformation, we have:

$$U_k(s) = k_1 [U_r(s) - U_f(s)] \dots \dots \dots (1)$$

$$U_f(s) = \alpha \Omega(s) \dots \dots \dots (2)$$

$$U_a(s) = k_2 U_k(s) \dots \dots \dots (3)$$

$$(T_e T_m s^2 + T_m s + 1) \Omega(s) = \frac{1}{C_e} U_a(s) - \frac{T_e T_m s + T_m}{J} \bar{M}(s) \dots \dots \dots (4)$$

(2) → (1) → (3) → (4), we have:

# Chapter 2 mathematical models of systems

$$[T_e T_m s^2 + T_m s + (1 + k_1 k_2 \alpha \frac{1}{C_e})] \Omega(s) = k_1 k_2 \frac{1}{C_e} U_r(s) - \frac{T_e T_m s + T_m}{J} \overline{M}(s)$$

$$G(s) = \frac{\Omega(s)}{U_r(s)} = \frac{k_1 k_2 \frac{1}{C_e}}{T_e T_m s^2 + T_m s + (1 + k_1 k_2 \alpha \frac{1}{C_e})}$$

here :  $T_e = \frac{L_a}{R_a}$  ..... *electric – magnetic time - constant*

$T_m = \frac{R_a J}{C_e C_m}$  ..... *mechanical – electric time - constant*

# Chapter 2 mathematical models of systems

## 2.6 block diagram models (dynamic)

Portray the control systems by the block diagram models more intuitively than the transfer function or differential equation models

### 2.6.1 Block diagram representation of the control systems

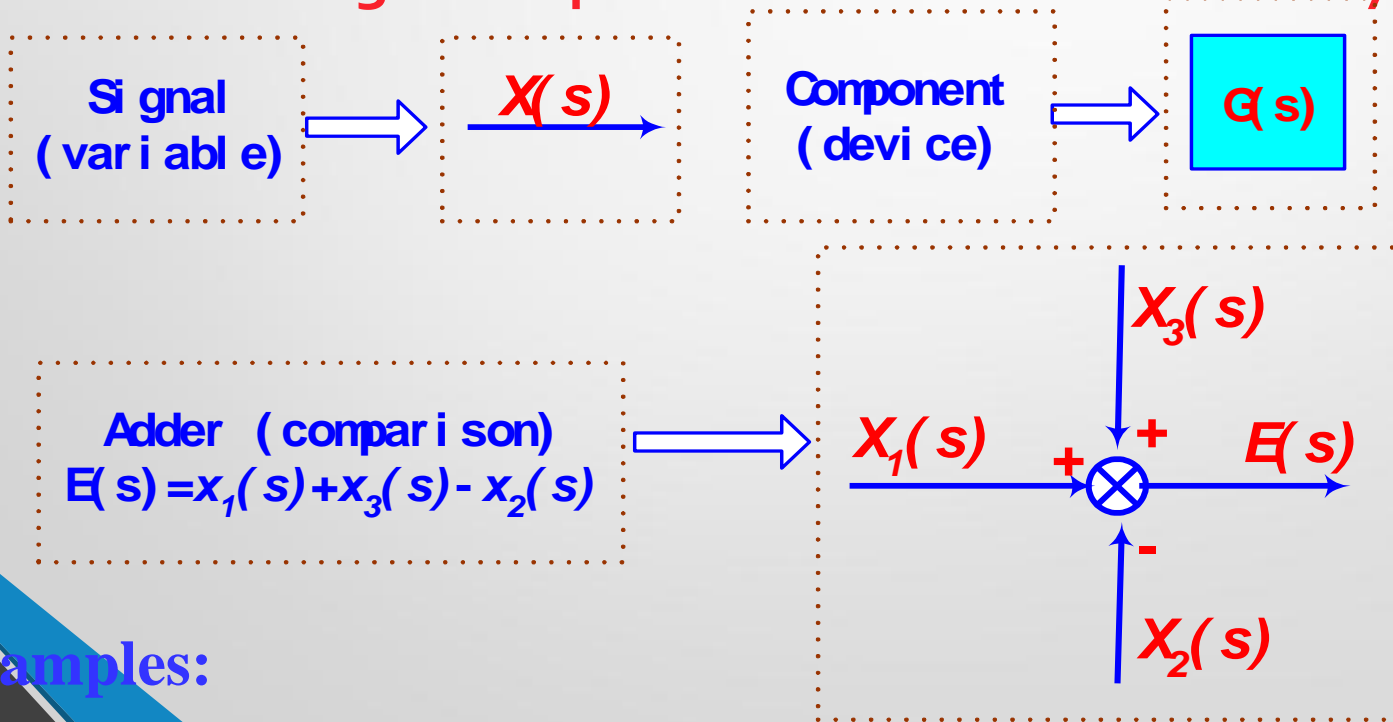

Examples:

# Chapter 2 mathematical models of systems

**Example 2.14** For the DC motor in Example 2.4

In Example 2.4, we have written down the differential equations as:

$$L_a \frac{di_a}{dt} + R_a i_a + E_a = u_a \dots(1) \quad M = C_m i_a \dots\dots\dots(2)$$

$$E_a = C_e \omega \dots\dots\dots(3) \quad M - \bar{M} = \bar{J} \frac{d\omega}{dt} + \bar{f} \omega \dots\dots(4)$$

Make Laplace transformation, we have:

$$L_a s I_a(s) + R_a I_a(s) + E_a(s) = U_a(s) \Rightarrow I_a(s) = \frac{U_a(s) - E_a(s)}{L_a s + R_a} \dots\dots\dots(5)$$

$$M(s) = C_m I_a(s) \dots\dots\dots(6)$$

$$E_a(s) = C_e \Omega(s) \dots\dots\dots(7)$$

$$M(s) - \bar{M}(s) = \bar{J} s \Omega(s) + \bar{f} \Omega(s) \Rightarrow \Omega(s) = \frac{1}{\bar{J} s + \bar{f}} [M(s) - \bar{M}(s)] \dots\dots(8)$$



# Chapter 2 mathematical models of systems

Draw block diagram in terms of the equations (5)~(8):

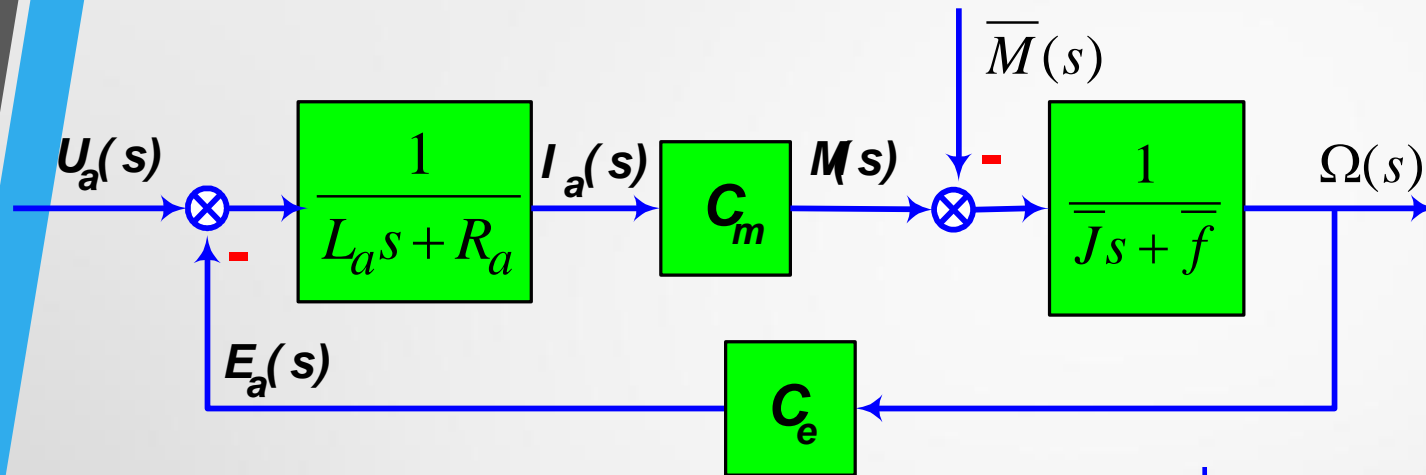

Consider the Motor as a whole:

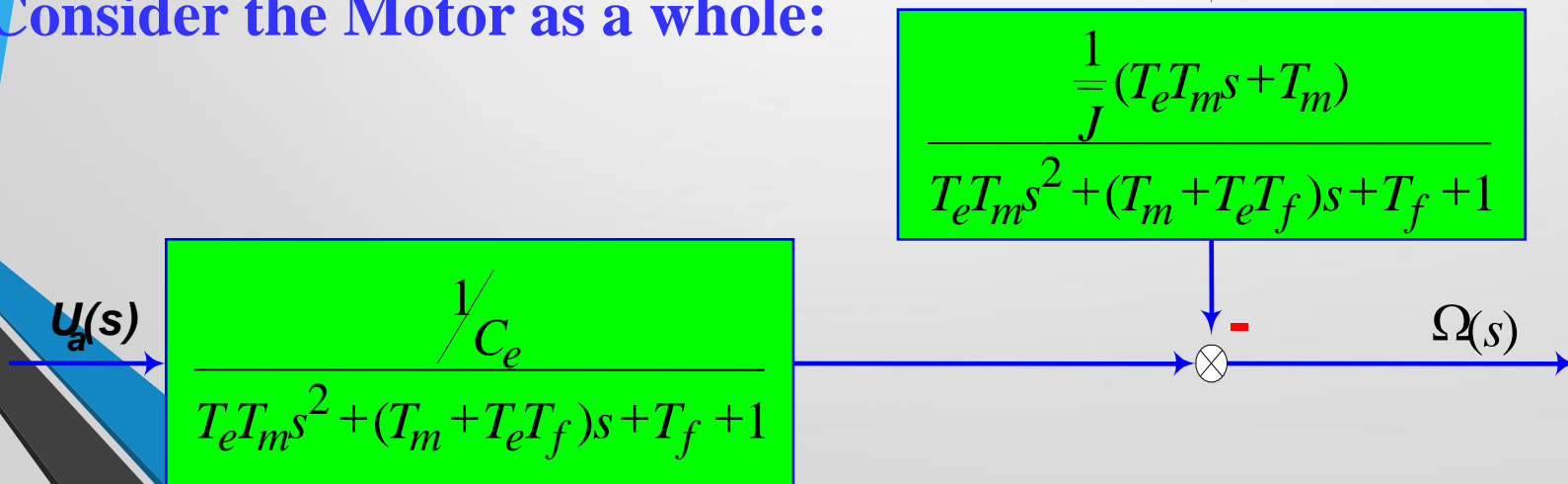

# Chapter 2 mathematical models of systems

**Example 2.15** The water level control system in Fig 1.8:

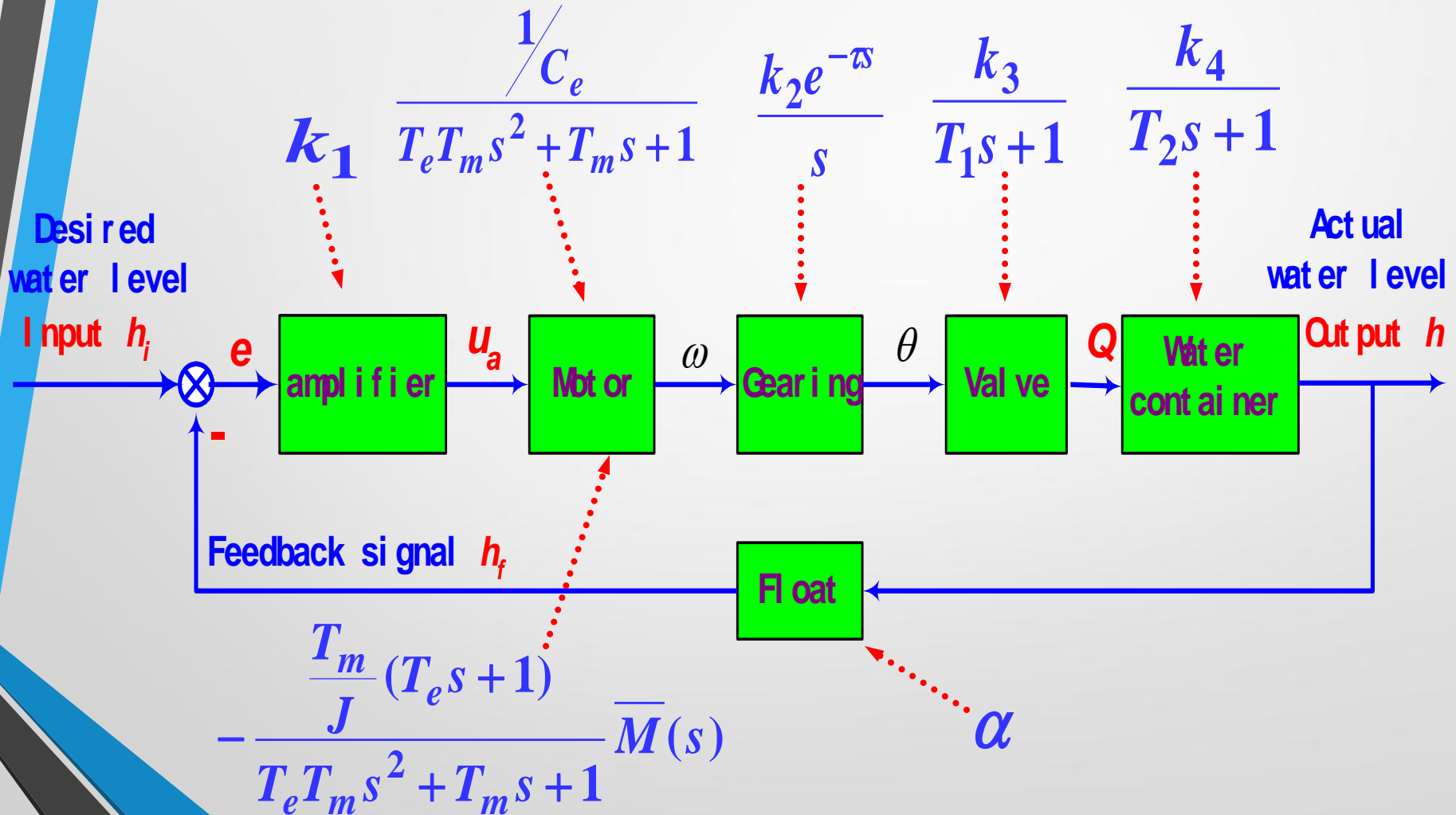

# Chapter 2 mathematical models of systems

The block diagram model is:

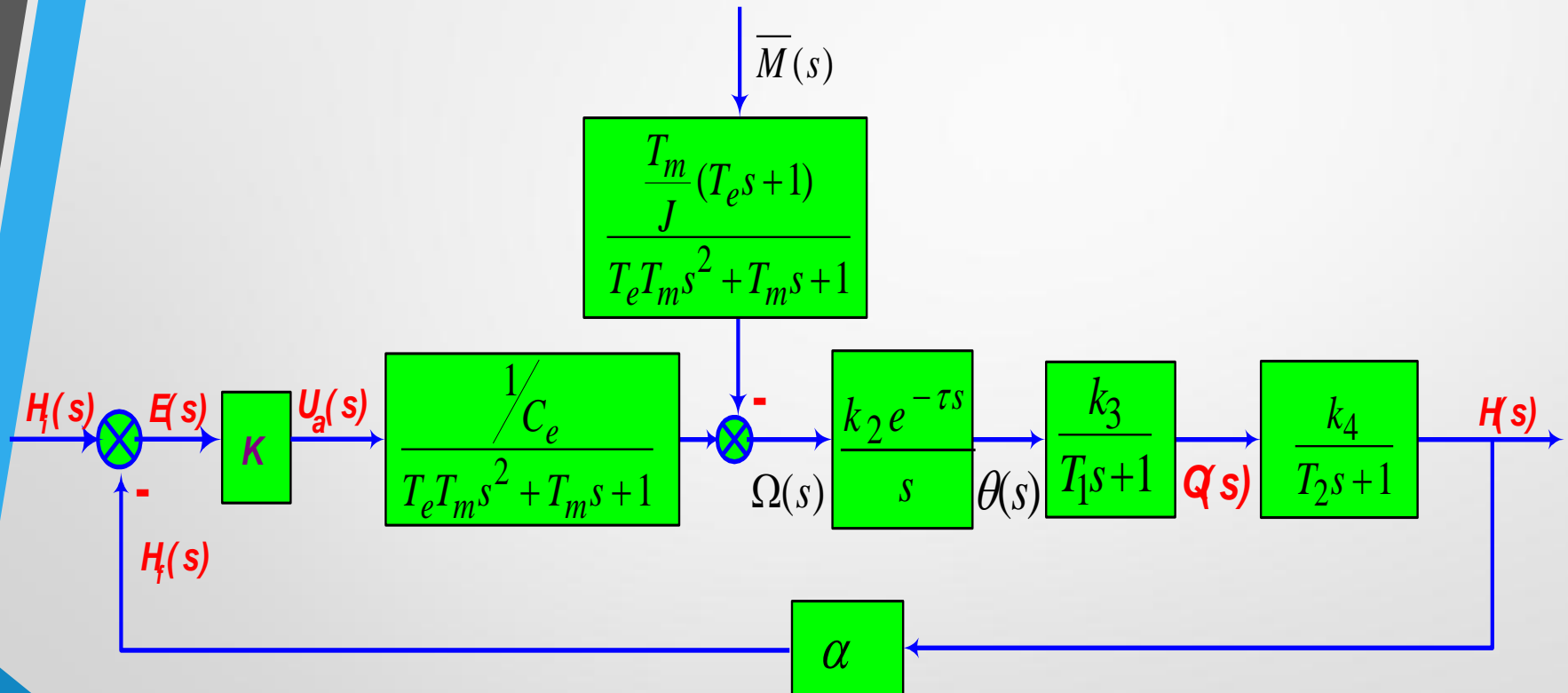

# Chapter 2 mathematical models of systems

## Example 2.16 The DC motor control system in Fig 1.9

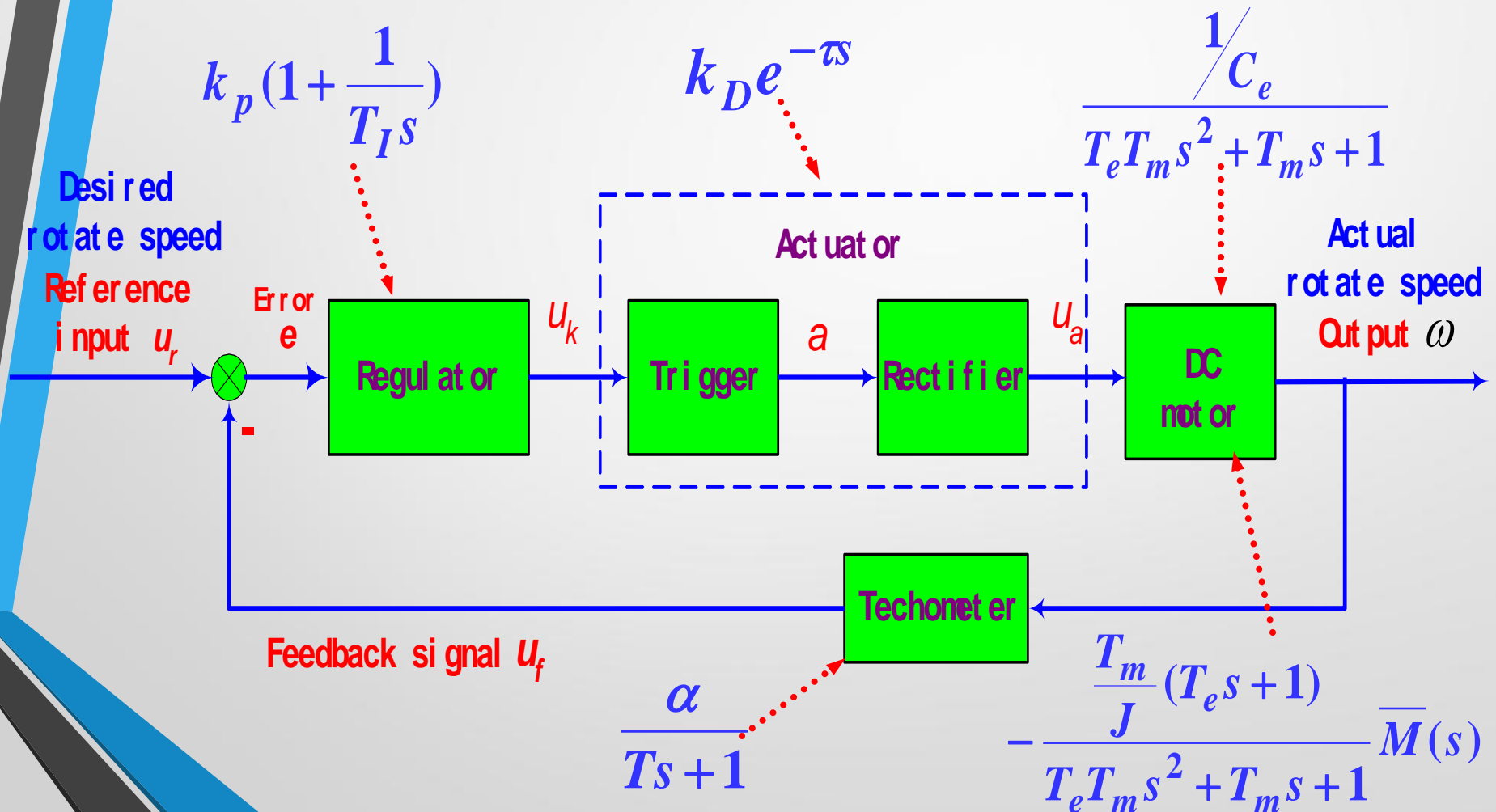

# Chapter 2 mathematical models of systems

The block diagram model is:

