

Lecture 13

APPLICATION LAYER

DOMAIN NAME SYSTEM

Topics Covered

- DNS
- Name Space
- Flat name space
- Hierarchical name space
- Distribution of name space
- DNS in the Internet
- Applications

INTRODUCTION

- A user of an e-mail program may know the e-mail address of the recipient; however, the IP protocol needs the IP address.
- The *DOMAIN NAME SYSTEM* client program sends a request to a DNS server to map the e-mail address to the corresponding IP address.

DNS – The Domain Name System

To identify an entity the internet uses the IP address which identifies the connection of a host to the internet.

But people prefer to use names instead of numeric addresses hence we need a system which can map a name to an address or address to a name . we use the DNS.

SMTP: Simple Mail Transfer Protocol (e-mail)
DNS: Domain Name System

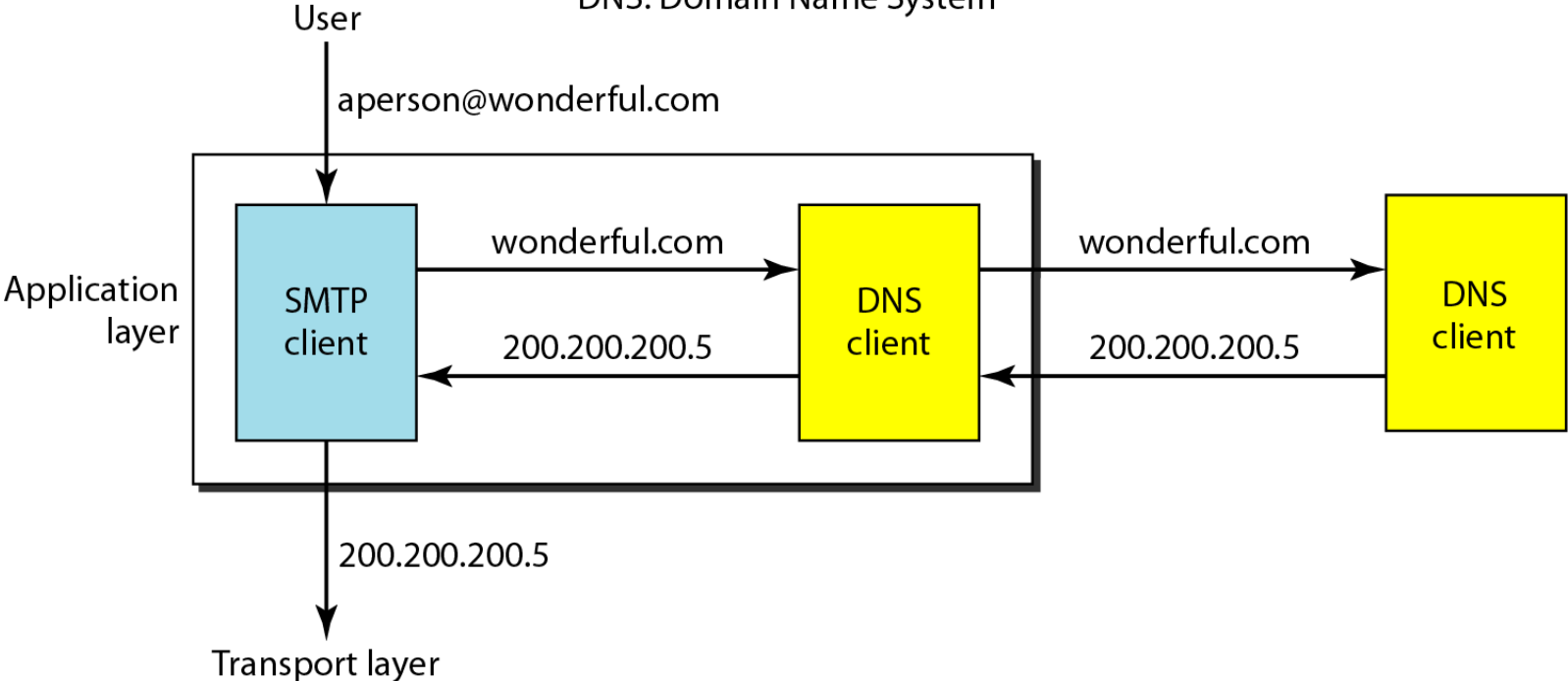

NAME SPACE

To be unambiguous, the names assigned to machines must be carefully selected from a name space with complete control over the binding between the names and IP addresses.

Topics discussed in this section:

Flat Name Space

Hierarchical Name Space

FLAT NAME SPACE

- A name is assigned to an address.
- A name in this space is a sequence of characters without structure.
- The main disadvantage of a flat name space is that it cannot be used in a large system such as the Internet because it must be centrally controlled to avoid ambiguity and duplication.

HIERARCHICAL NAME SPACE

- Each name is made of several parts.
- The first part can define the nature of the organization,
- the second part can define the name of an organization,
- the third part can define departments in the organization, and so on .
- Ex challenger.jhda.edu, challenger.berkeley.edu, and challenger.smart.com.
- To have a hierarchical name space, a **domain name space** was designed.

DOMAIN NAME SPACE

To have a hierarchical name space, a domain name space was designed. In this design the names are defined in an inverted-tree structure with the root at the top. The tree can have only 128 levels: level 0 (root) to level 127.

Topics discussed in this section:

Label

Domain Name

Domain

Domain name space

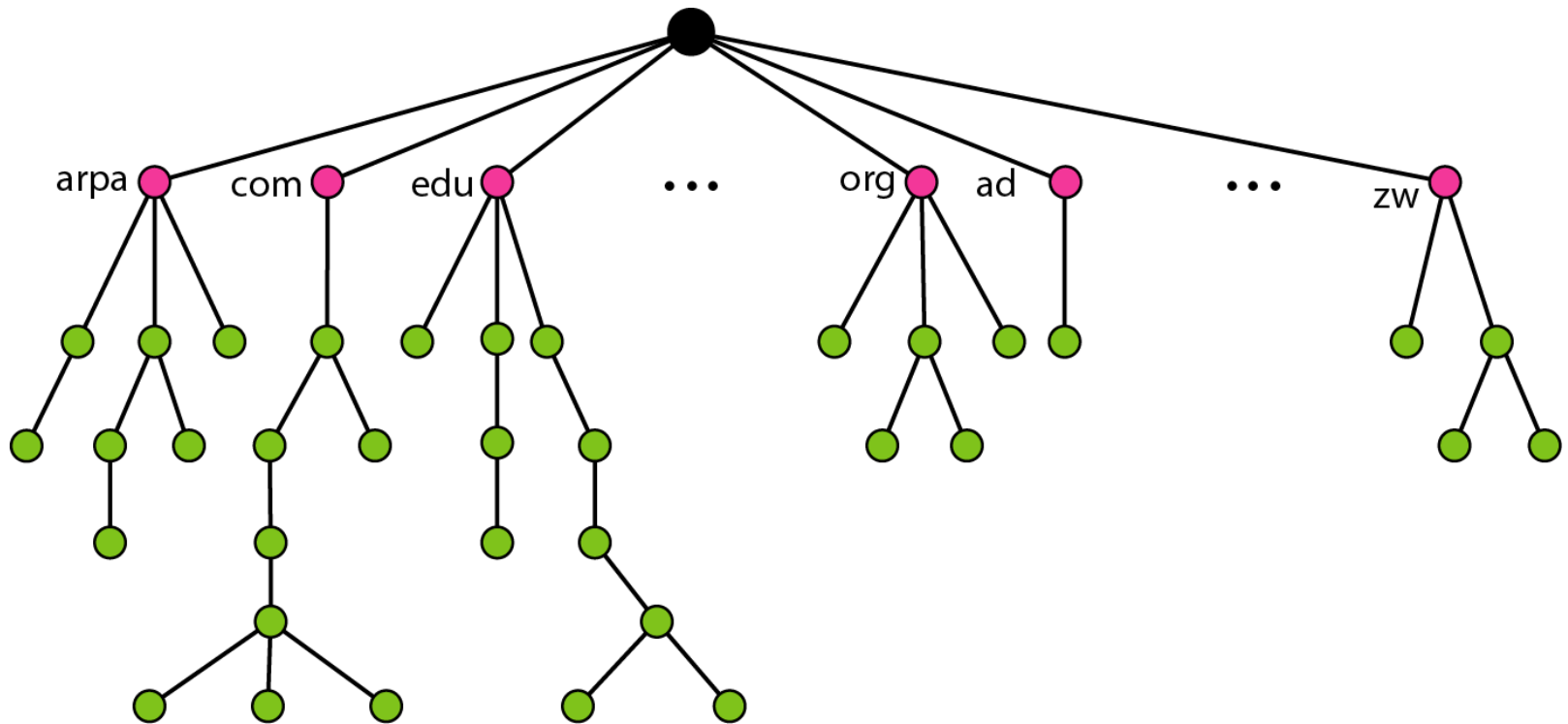

A portion of the Internet domain name space.

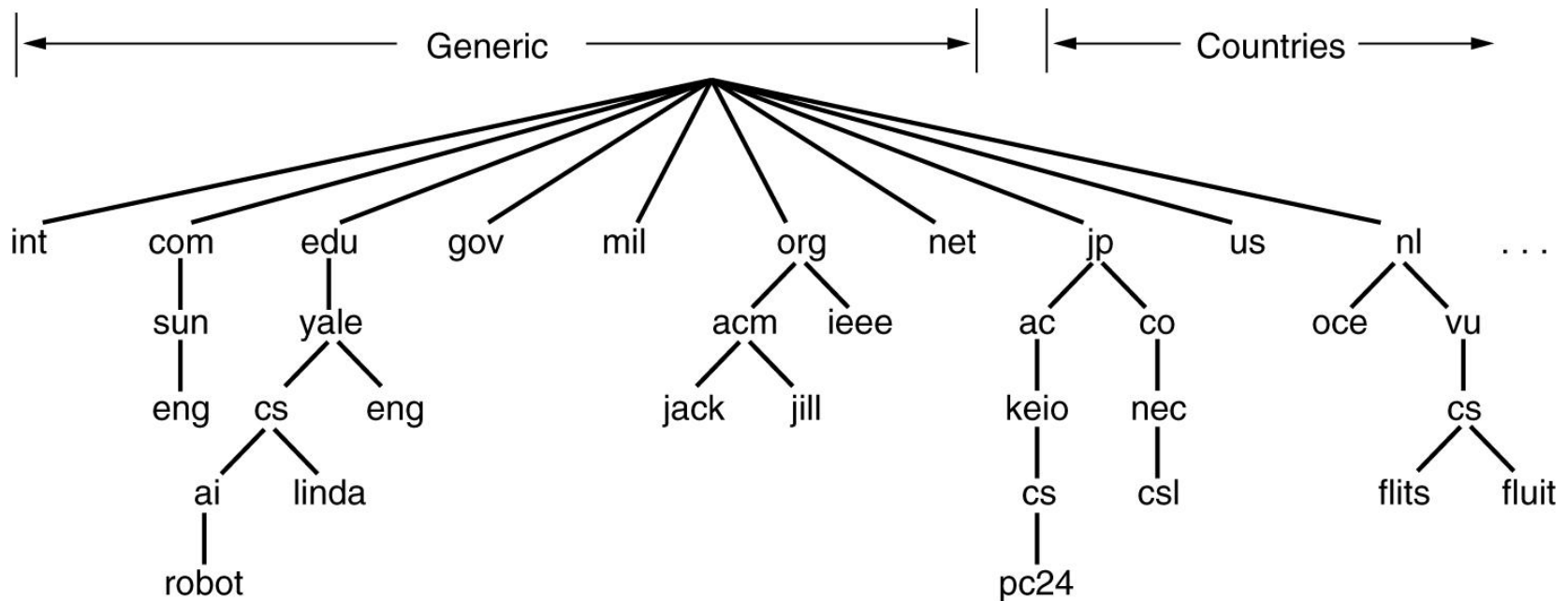

Domain names and labels

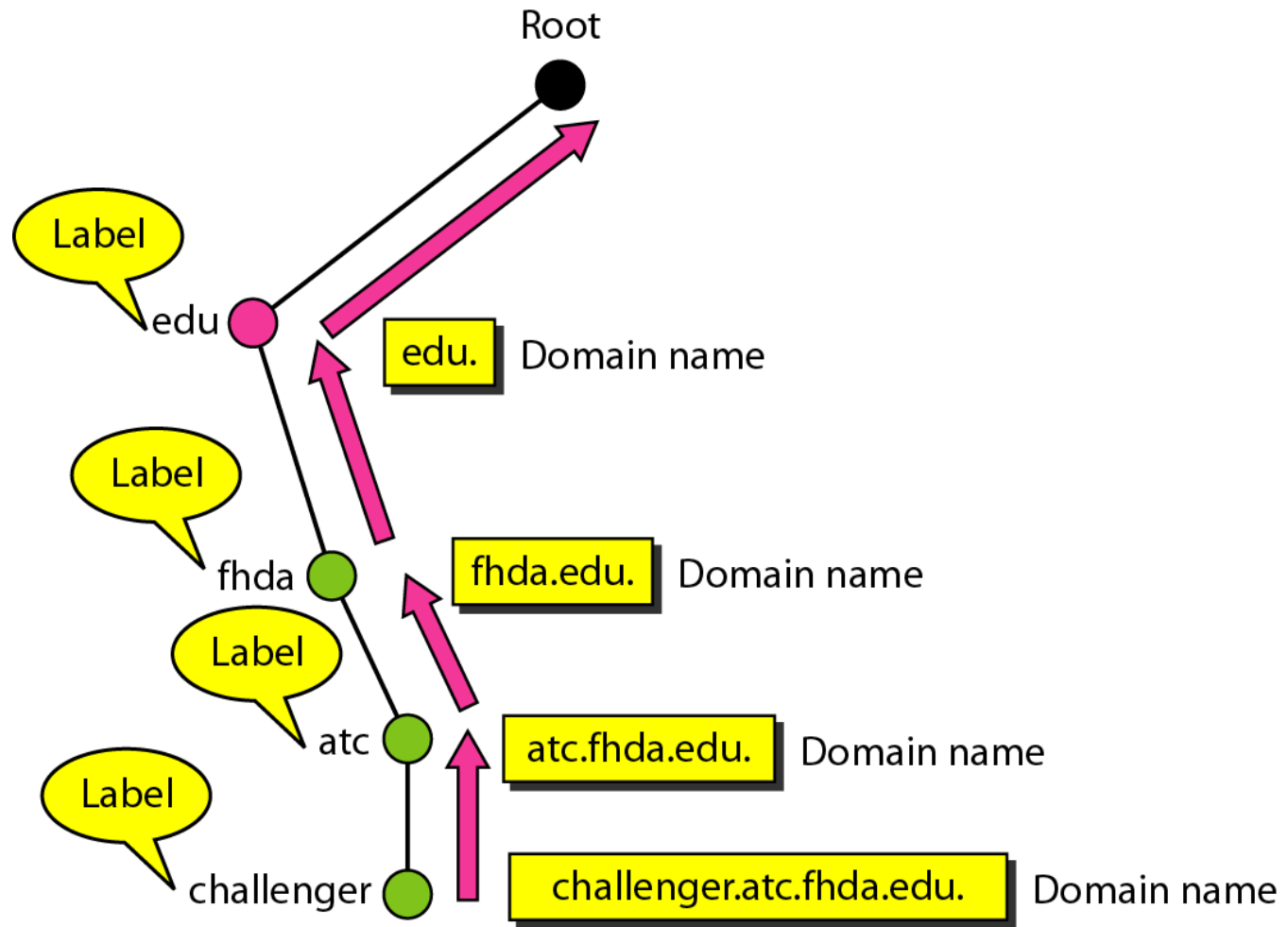

Label

Each node in the tree has a label, which is a **string with a maximum of 63 characters** . The root label is a empty string. DNS requires that children of a node have different labels, which guarantees the uniqueness of the domain names.

Domain Name

Each node in the tree has a domain name. A full domain name is a sequence of labels separated by dots (.). The domain names are always read from the node up to the root. The last label is the label of the root (null). This means that a full domain name always ends in a null label, which means the last character is a dot because the null string is nothing.

Domain

A domain is a sub tree of the domain name space. The name of the domain is the domain name of the node at the top of the sub tree. Note that a domain may itself be divided into domains.

Domains

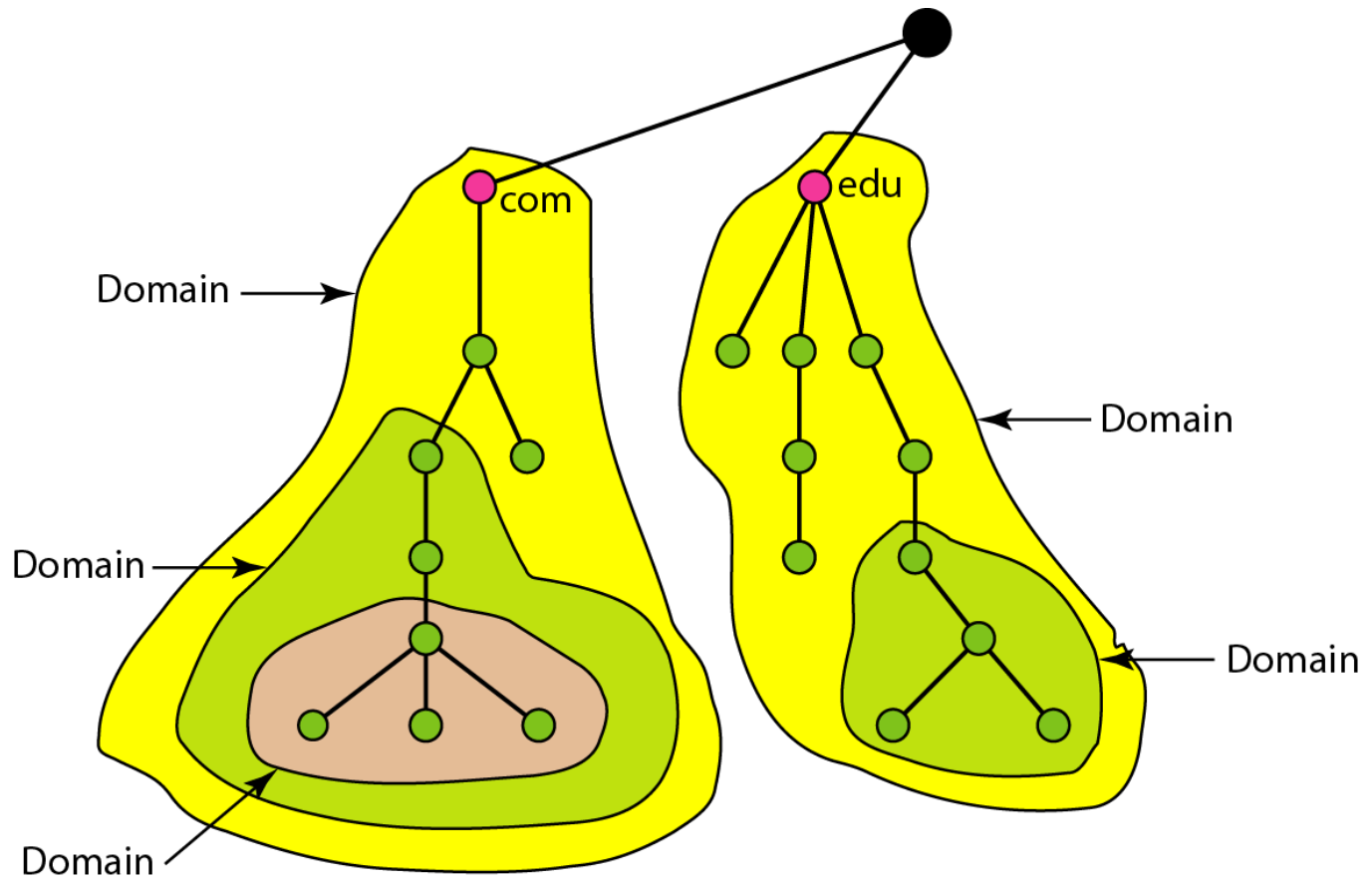

DISTRIBUTION OF NAME SPACE

The information contained in the domain name space must be stored. However, it is very inefficient and also unreliable to have just one computer store such a huge amount of information. In this section, we discuss the distribution of the domain name space.

Topics discussed in this section:

Hierarchy of Name Servers

Zone

Root Server

Primary and Secondary Servers

Hierarchy of Name Servers

The solution to these problems is to distribute the information among many computers called DNS servers. One way to do this is to divide the whole space into many domains based on the first level. DNS allows domains to be divided further into smaller domains (subdomains). Each server can be responsible (authoritative) for either a

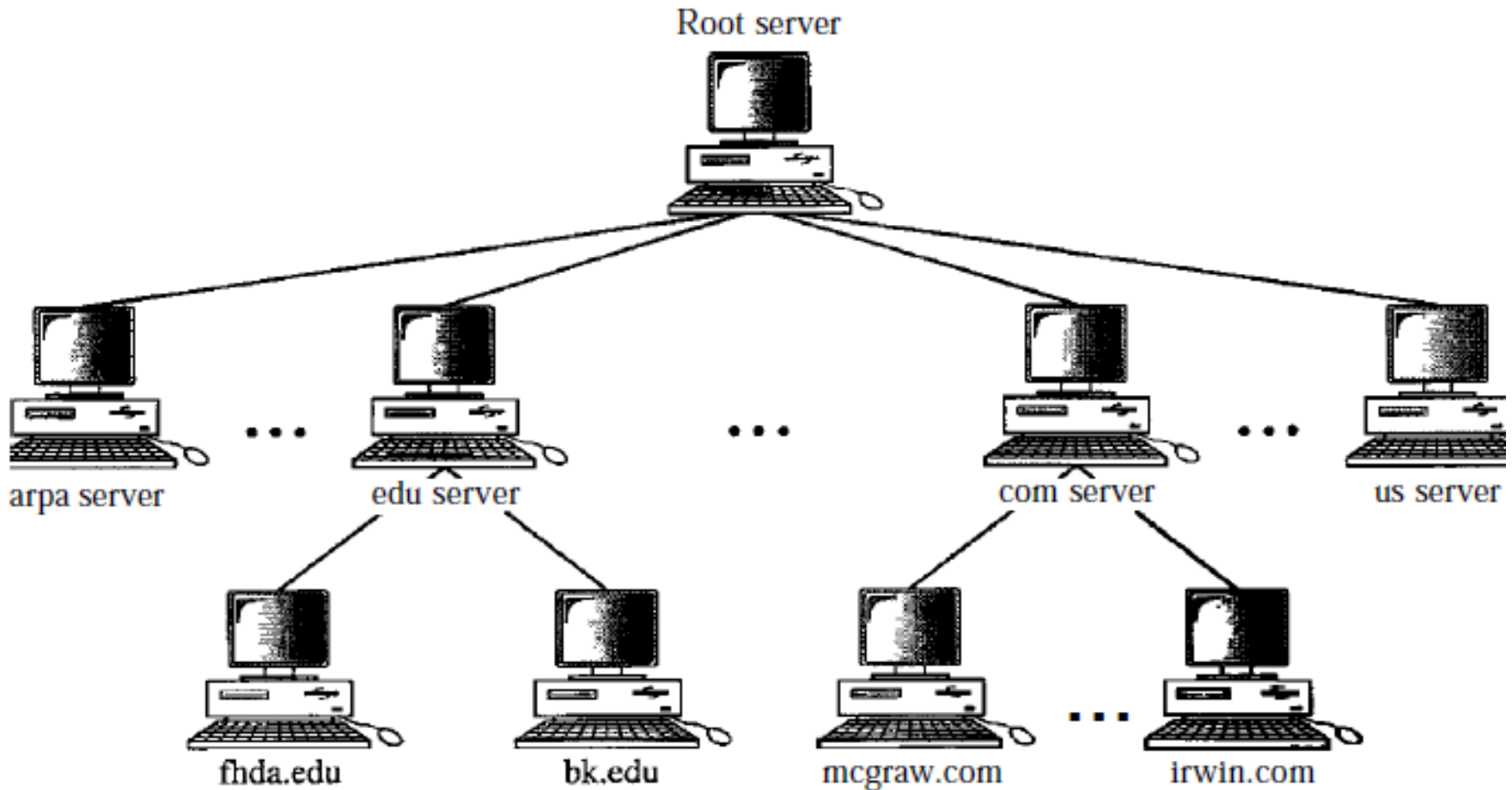

Zone

Since the complete domain name hierarchy cannot be stored on a single server, it is divided among many servers. What a server is responsible for or has authority over is called a zone. We can define a zone as a contiguous part of the entire tree.

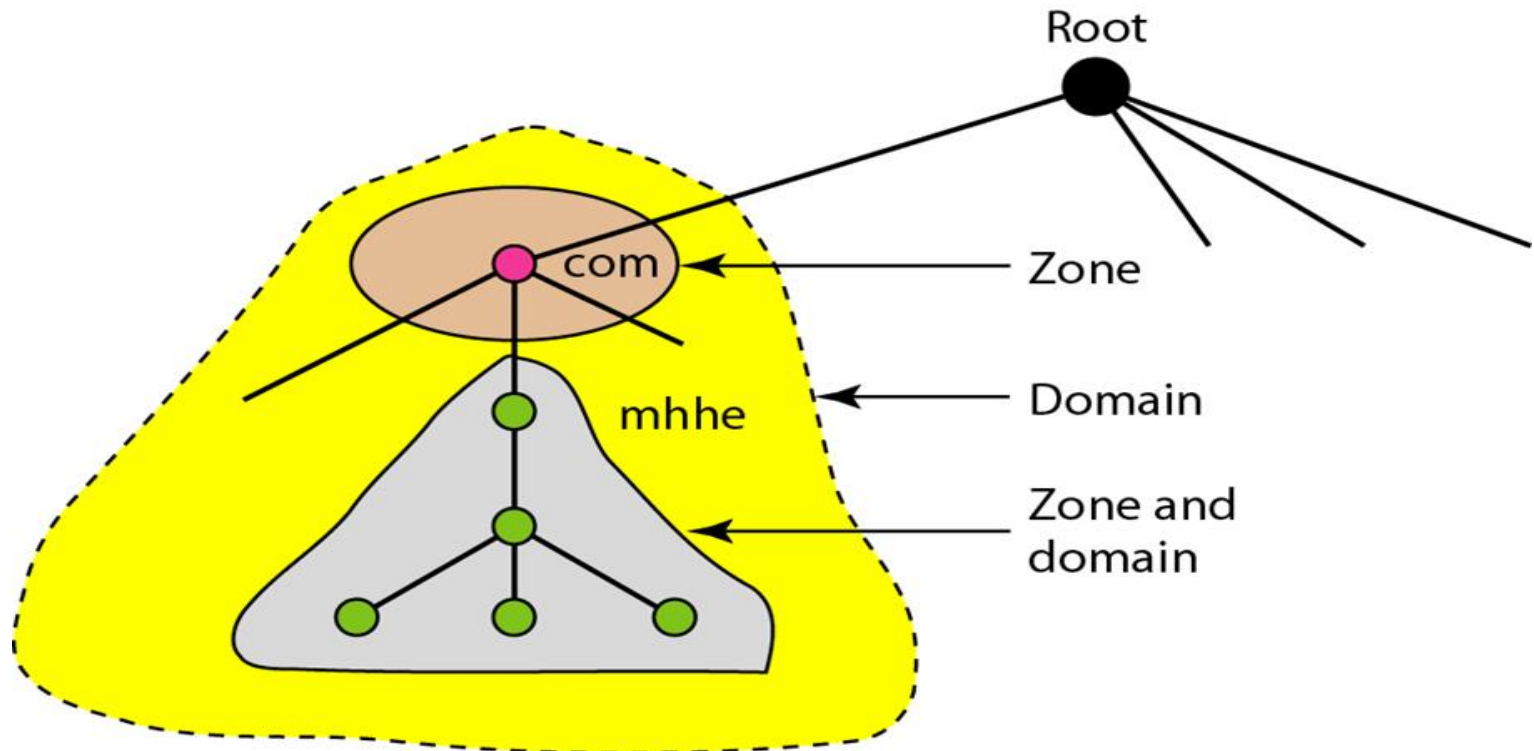

Root Server

A root server is a server whose zone consists of the whole tree. A root server usually does not store any information about domains but delegates its authority to other servers, keeping **references** to those servers. There are several root servers, each covering the whole domain name space. The servers are distributed all around the world.

Primary and Secondary Servers

DNS defines two types of servers: primary and secondary.

A primary server is a server that stores a file about the zone for which it is an authority. It is responsible for creating, maintaining, and updating the zone file. It stores the zone file on a local disk.

A secondary server is a server that transfers the complete information about a zone from another server (primary or secondary) and stores the file on its local disk. The secondary server neither creates nor updates the zone files. If updating is required, it must be done by the primary server, which sends the updated version to the secondary.

DNS IN THE INTERNET

DNS is a protocol that can be used in different platforms. In the Internet, the domain name space (tree) is divided into three different sections: generic domains, country domains, and the inverse domain.

Topics discussed in this section:

Generic Domains

Country Domains

Inverse Domain

DNS in the Internet

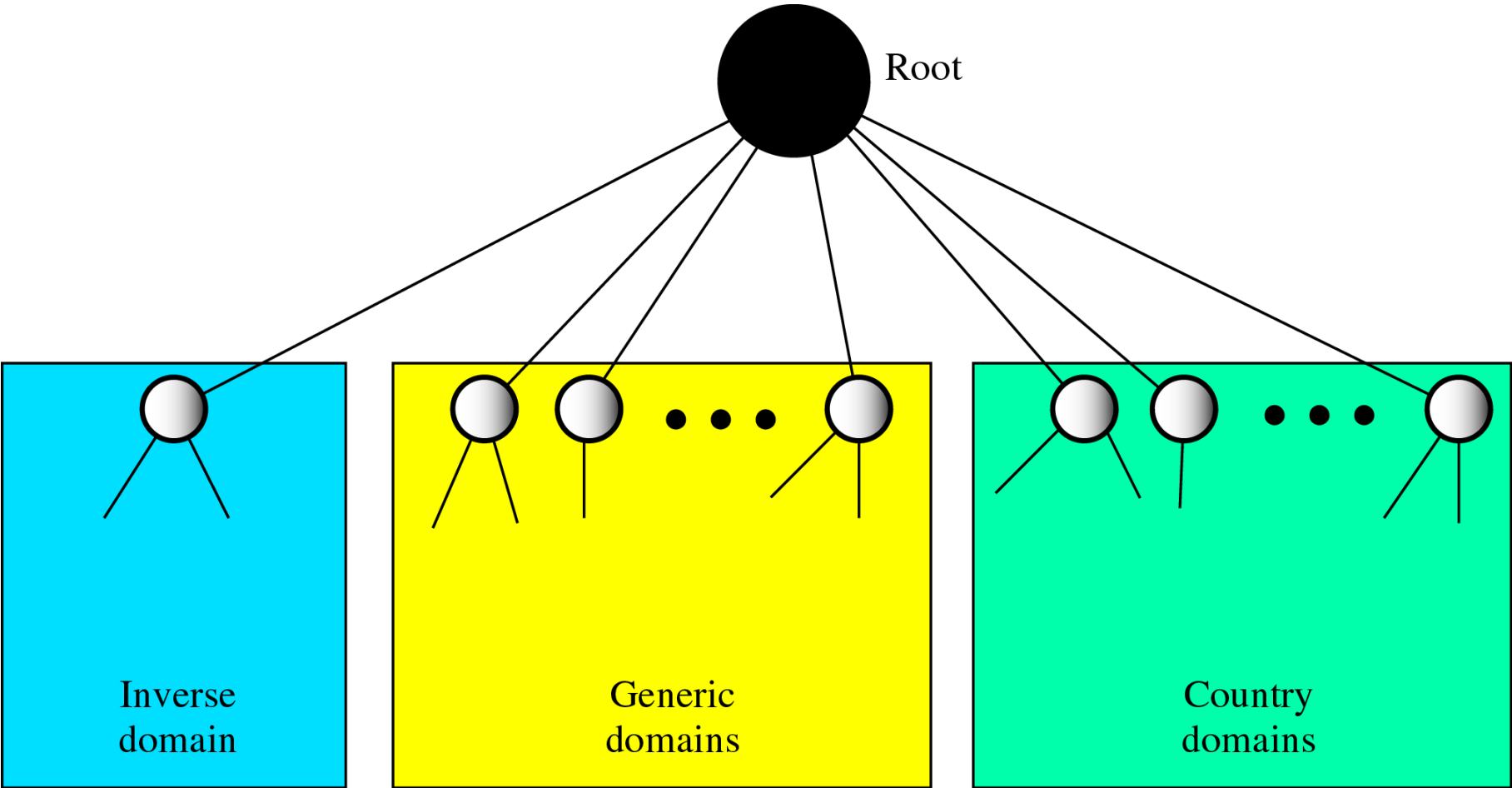

Generic Domains

The generic domains define registered hosts according to their generic behavior.

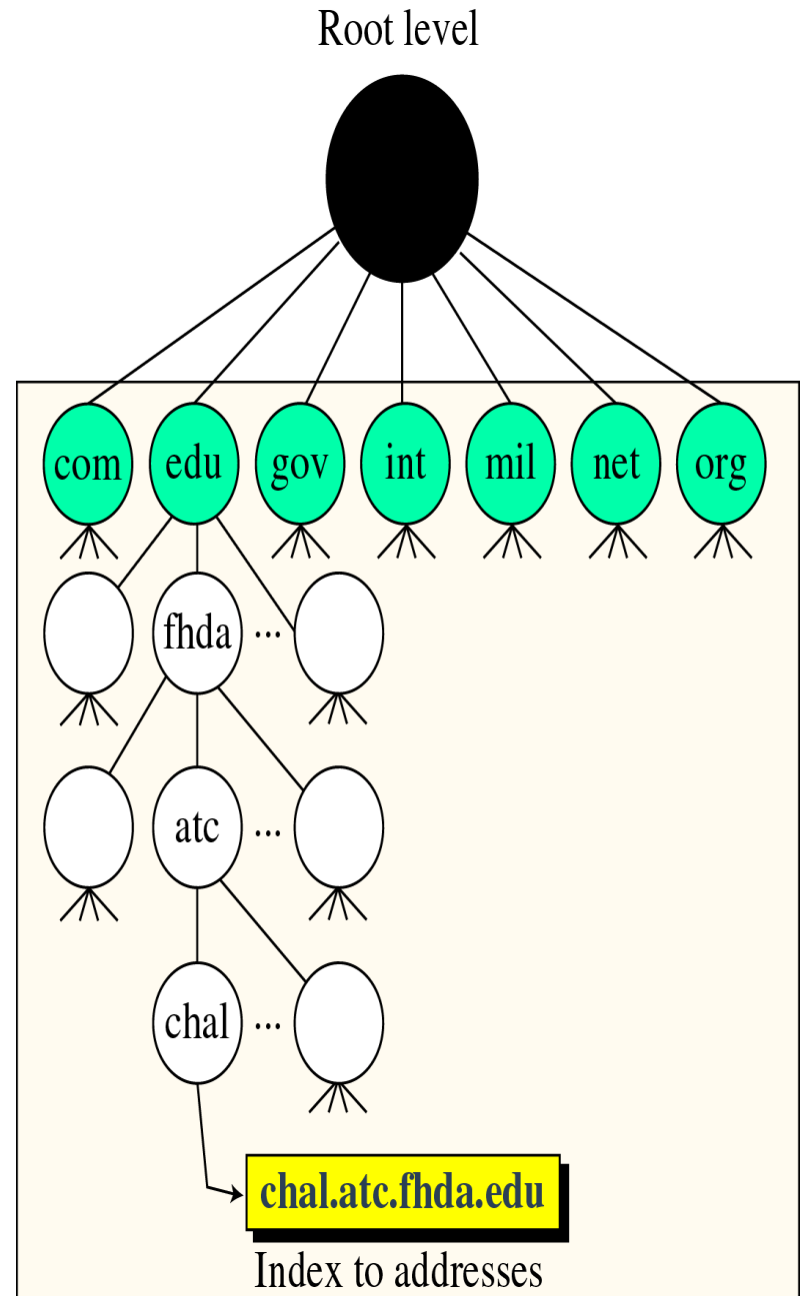

<i>Label</i>	<i>Description</i>
aero	Airlines and aerospace companies
biz	Businesses or firms (similar to "com")
com	Commercial organizations
coop	Cooperative business organizations
edu	Educational institutions
gov	Government institutions
info	Information service providers
int	International organizations
mil	Military groups
museum	Museums and other nonprofit organizations
name	Personal names (individuals)
net	Network support centers
org	Nonprofit organizations
pro	Professional individual organizations

Country Domains

Root level

The country domains section uses two-character country abbreviations (e.g., us for United States). Second labels can be organizational, or they can be more specific, national designations.

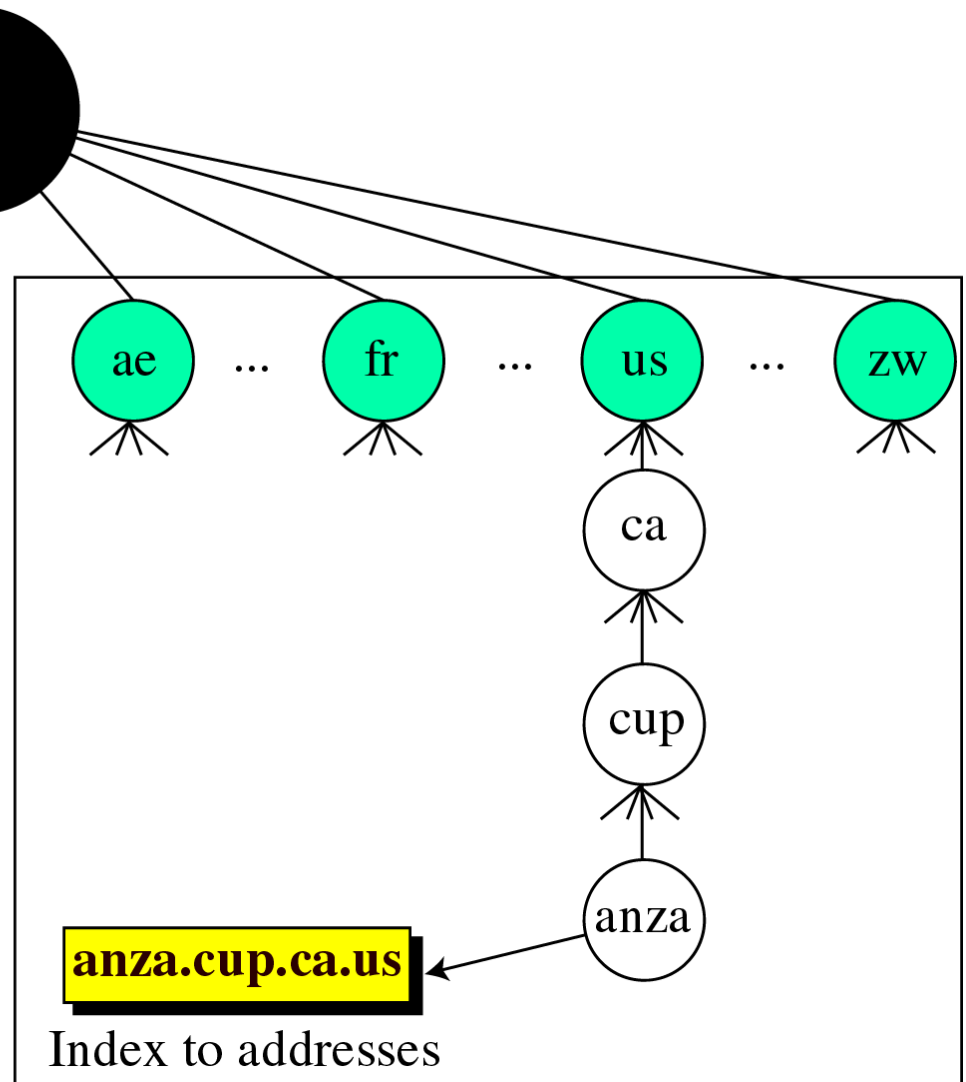

Inverse Domain

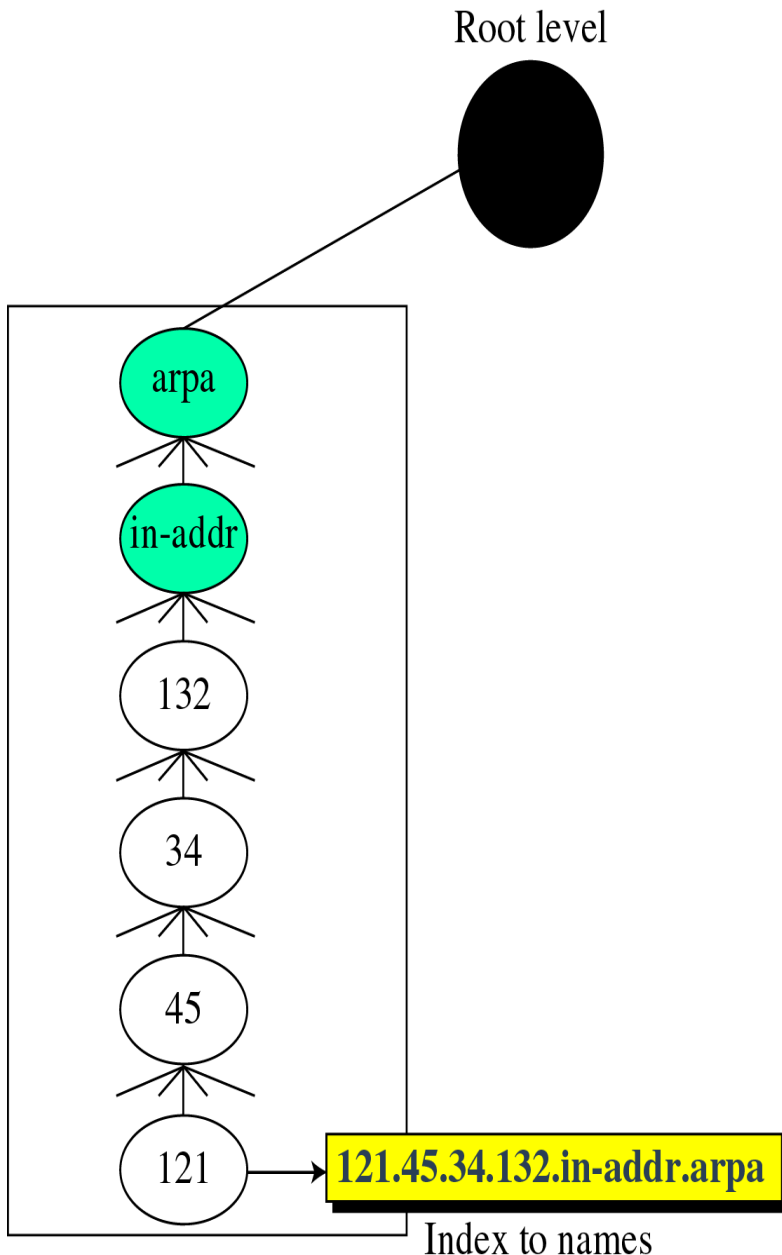

The inverse domain is used to map an address to a name

To handle a pointer query, the inverse domain is added to the domain name space with the first-level node called arpa (for historical reasons). The second level is also one single node named in-addr (for inverse address). The rest of the domain defines IP addresses



Example

- To resolve `www.yahoo.com`, first contact root server to get name server for *com*
- Querying name server for *com* gives name server for *yahoo.com*
- Querying name server for *yahoo.com* gives IP address of *www.yahoo.com*
- Three queries needed to resolve the name in the worst case

APPLICATION

- Address Resolution
- Easy identification of nodes in the networks
- Standard for specifying domain names to nodes and applications