

Wireless Mobile Communication

Lecture 30

- ISDN
- (Integrated Services Digital Network)

Chapter Objectives

- Define ISDN, its standards and the type of services offered
- Describe the two main types of services, namely BRI and PRI
- Give examples of ISDN links
 - Simple SOHO line, ISDN remote bridges etc
- Briefly outline a few other features of ISDN

Topics to be Covered

- An overview of ISDN
- Basic Rate Interchange (BRI)
- Primary Rate Interchange (PRI)
- A practical SOHO ISDN line
- ISDN applications
- Other features of ISDN

MODULE

An Overview of ISDN

ISDN Defined

- Known as the Integrated Services Digital Network
 - Data, audio, image and video transmission
- It is a switched digital telecommunication line that can be delivered over regular copper wires
 - Possible to provide end-to-end digital communications

ISDN Application Examples

- On/off ramp to the information super-highway to communicate at speeds of 128 Kbps for a single ISDN line
 - Multiple ISDN lines can be combined together to achieve higher communication speeds
- Home use
 - On/Off ramp to the Internet
- Business world
 - Provide remote access to LANs

ISDN Standard

- There is a national ISDN standard known as the NI standard
- It is being implemented in phases
- Current implementation is termed as NI-1 to indicate that it is in phase 1 of the implementation process

ISDN Connections

- Can be obtained from a local telephone company in the same way an analog connection is obtained
- Phone companies offer different types of ISDN connections

ISDN Basic Characteristics

B Channels
64 Kbps

D Channel
16-64 Kbps

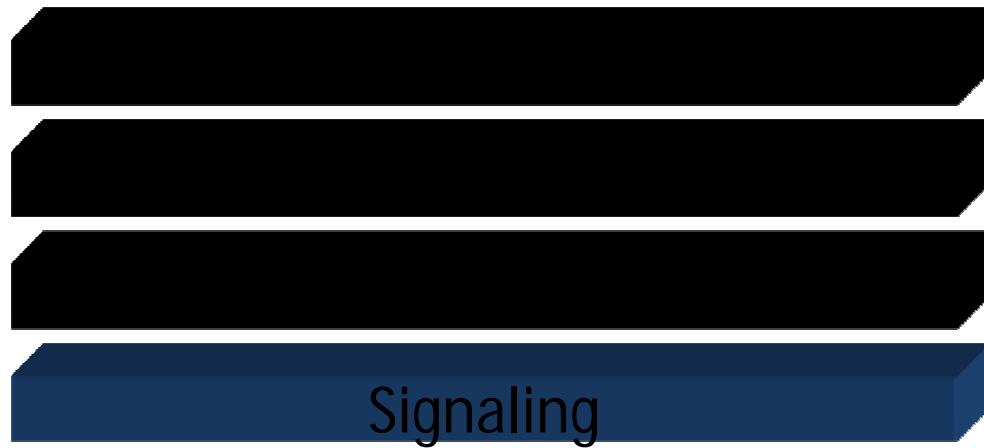

Inverse Multiplexing of B Channels

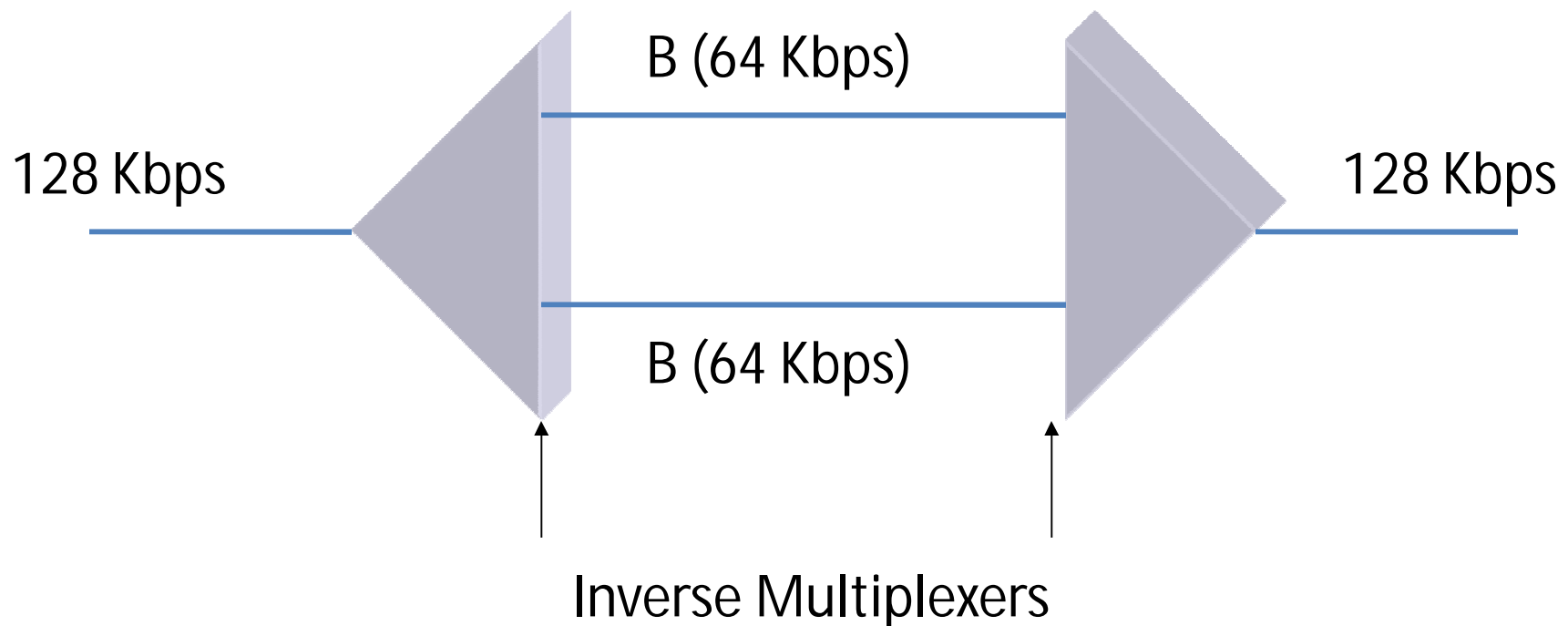

Bonding of B Channels or BOD (Bandwidth on Demand)

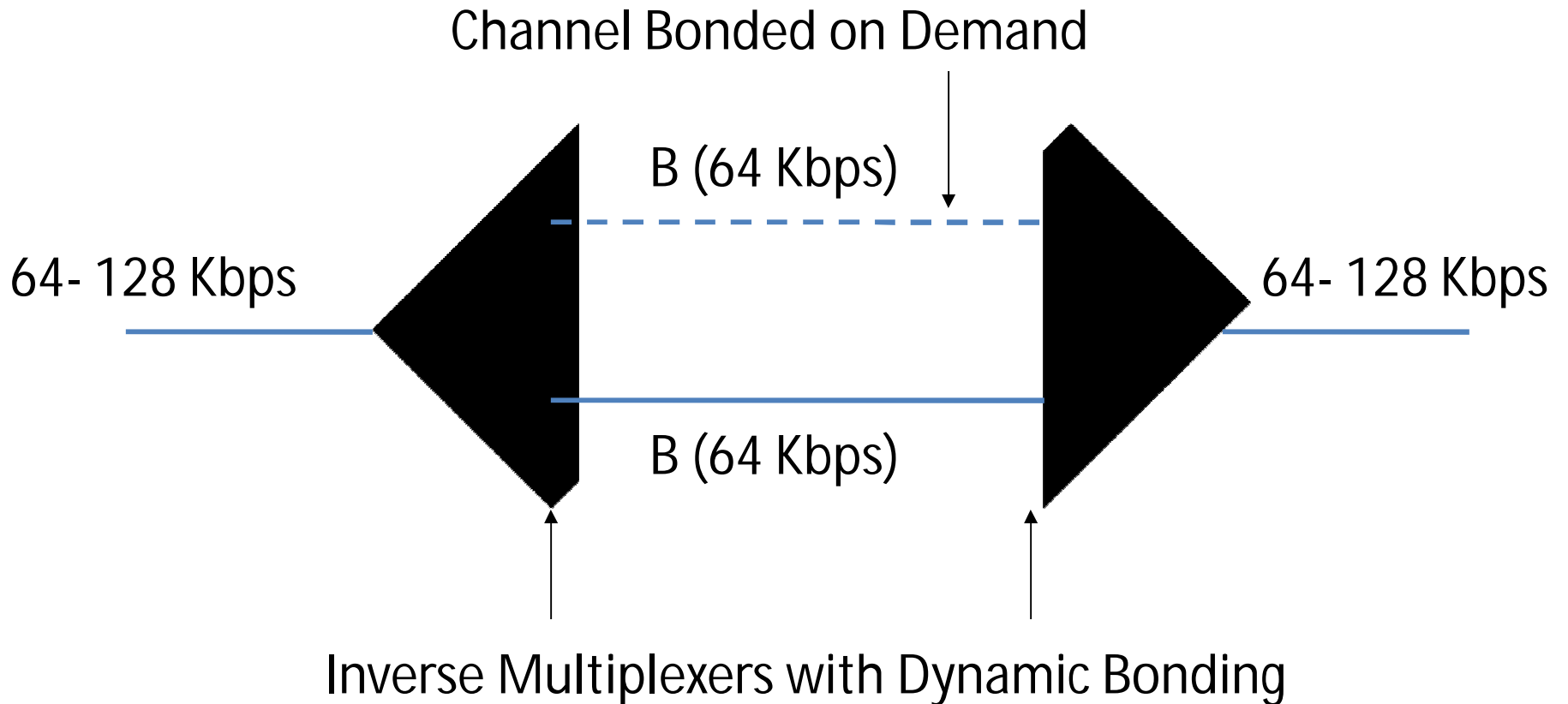

ISDN Service Connections

- There are two different types of ISDN services that are widely available
- One is known as the Basic Rate Interface or BRI
 - Used for home or SOHO connection
- The other is known as the Primary Rate Interface or the
 - Used in large businesses

World-wide Coverage

- U.K.
- India
- Germany
- France
- Australia
- Japan
- Canada
- etc.

In Summary

- ISDN is a switched digital network
- Can be used for establishing a point-to-point digital connection
- BRI and PRI
 - Number of B Channels vary in each case
- B channels can be combined together to achieve a higher communication speed



END OF MODULE

MODULE

Basic Rate Interface (BRI)

BRI Characteristics

- 2 B Channels
- 1 D Channel

A Simple BRI Connection to a Microcomputer

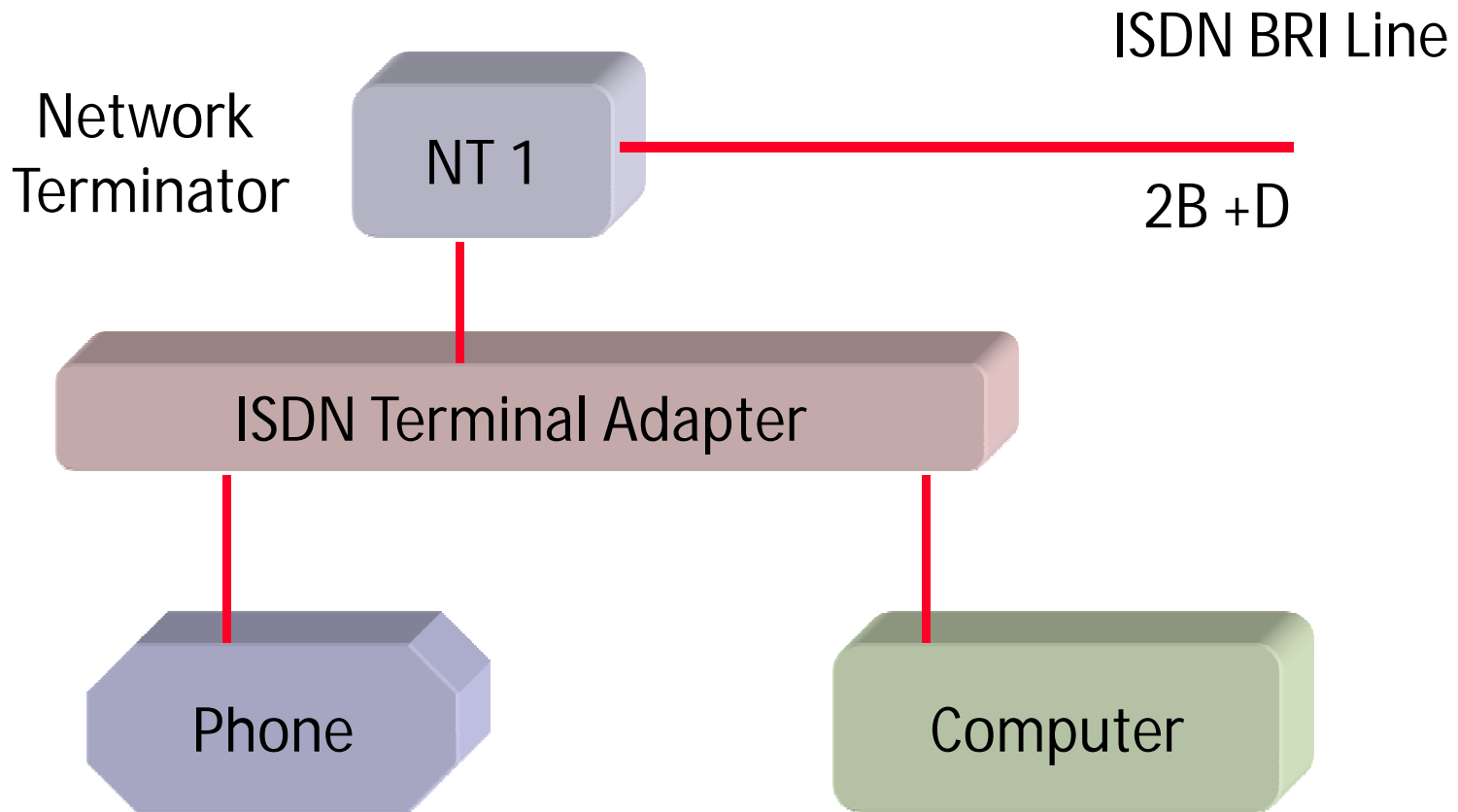

Channels in BRI Service

- B channels are known as bearer channels
 - Carry information
- D channel is known as the Delta channel
 - Used for signaling purposes
- 2B + D channel service

The B Channel

- 64k bps per channel
- The two B channels can be inverse multiplexed or boded together
 - Achieve a maximum aggregate communication speed of 128 Kbps

The D Channel

- 16 Kbps
- Entire bandwidth is not used for signaling purpose
- Excess of 9.6 Kbps is available for packet switched data transmission applications
- Excess bandwidth usage
 - Climate control, security alarm system etc.

In Summary

- BRI is the basic ISDN service
- Composed of 2 B channels and a D channel
- B Channels are circuit switched
- D Channel is packet switched
 - Excess capacity can be utilized for packet switched applications



END OF MODULE

MODULE

Primary Rate Interface (PRI)

PRI Service

- More sophisticated service compared to BRI
- PRI service offers 23 B channels and 1 D channel

Properties of B Channels in PRI

- Each B channel operates at a speed of 64K bps
- The B channels are used for carrying data
- B channels can be combined together to increase the aggregate communication speed

Properties of D Channel in PRI

- Each D channel operates at a speed of 64 Kbps
 - Considerably faster than the D channel in BRI
- 23 B channels share a D channel for signaling purpose

PRI Channel Delivery

- PRI channels are delivered over a T1 line
- T1 speed
 - 1.544M bps
- Aggregate speed of PRI from all 23 B channels and the single D Channel is computed as follows:
 - $23 * 64 + 64 + xx = 1.544 \text{ Mbps}$

Sample Services (PacBell)

- Centrex ISDN
 - For businesses that already have the Pac Bell's centrex phone system
- SDS-ISDN
 - BRI service offered for small businesses
 - Charges
 - Per channel
 - Per minute

Sample Services (ISDN)

- Home ISDN
 - Offers a BRI connection
 - 2B + D
 - Charges are cheaper especially during off-peak hour
 - Per channel
 - Per minute
- SDS-56
 - Single channel switched 56 Kbps digital service

Sample Cost Comparison

Service	Month	Inst.	Usage	
Cen-ISDN	31.65	220.75	Bus. Measured	
SDS-ISDN	26.04	190.75	Bus. Measured	
Home ISDN	24.50	159.75	8-5 Bus. Measured	
PRI	220.00	750	Flat Otherwise	
SDS- 56	45.00	500	Bus Measured	

* Rebates may apply to Installation



END OF MODULE

MODULE

Sample ISDN Applications

Use of ISDN Adapters

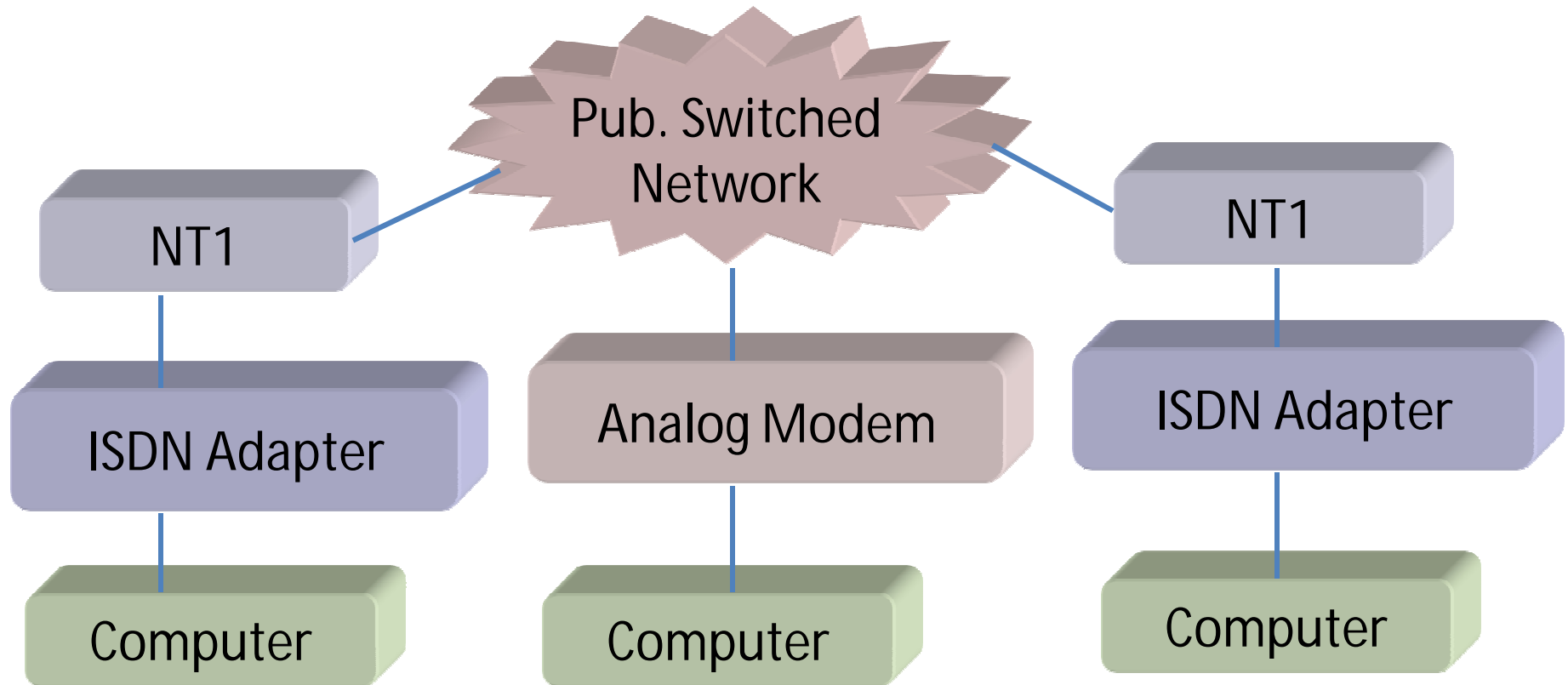

Remote ISDN Access to a LAN

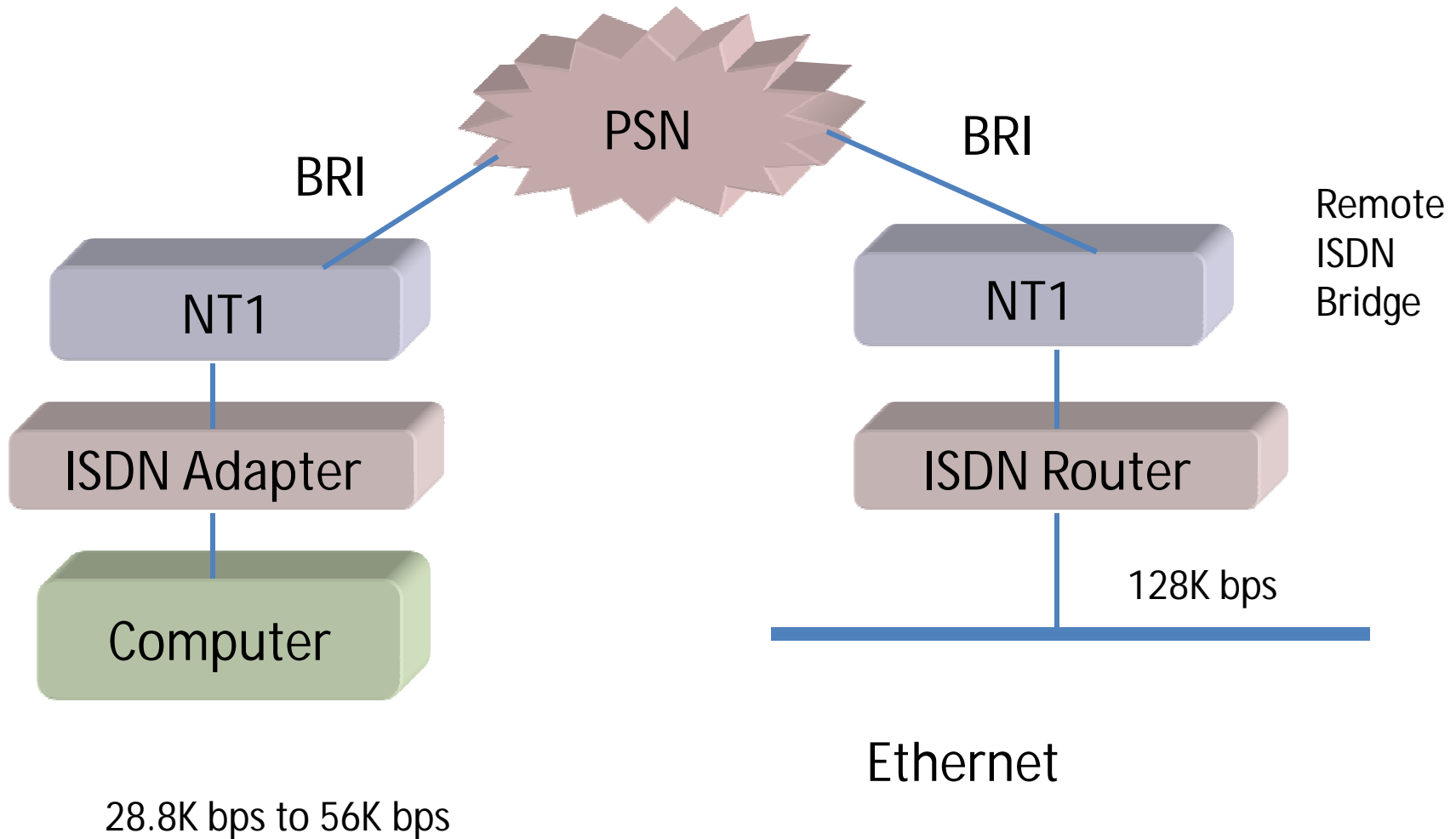

Remote Access Over PRI

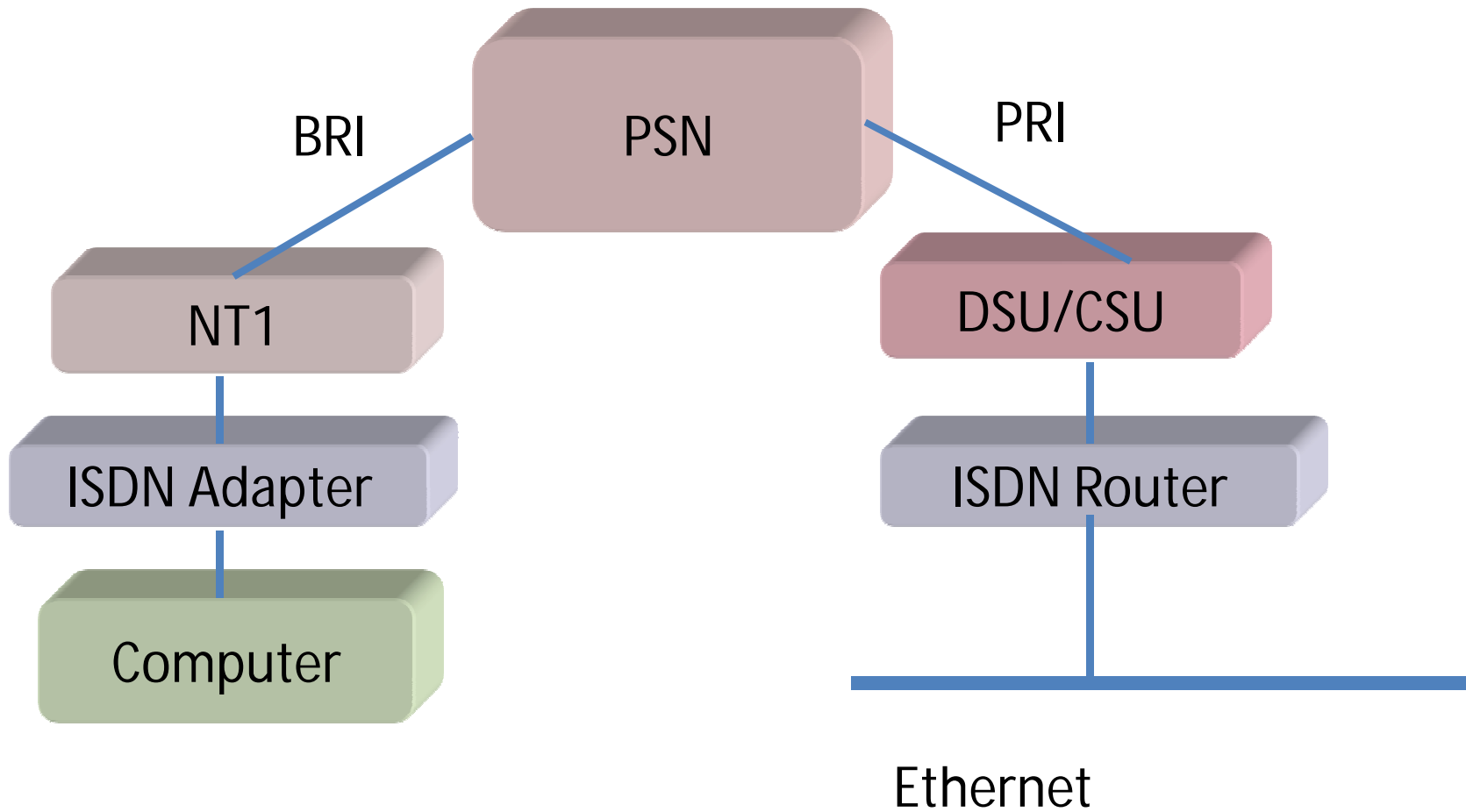

Important Features of the PRI Connection

- Communication links can be established between:
 - remote computers and this LAN
 - this LAN and remote locations
 - this LAN and other remote LANs
- Link is established using a powerful router
- A separate DSU/CSU unit is used as opposed to the NT1 network terminator used in the case of BRI

Commercial Examples of ISDN Equipment

- ISDN adapter
 - 3Com Impact IQ
- ISDN routers
 - Ascend and Cisco are sample manufacturers
 - Ascend Pipeline 50 and Ascend Pipeline 100 are examples of such routers
- For the latest information on ISDN equipment access the manufacturers' web sites

ISDN Use in Video Conferencing

- Dynamic bandwidth allocation
- Circuit switched
- Symmetric bandwidth