



Analog Communication Systems

EC-413-F



Lecture no 1,2



Topics to be covered

AM Generation

Low-level generation

- In modern radio systems, modulated signals are generated via digital signal processing (DSP).
- With DSP many types of AM modulation are possible with software control (including DSB with carrier, SSB suppressed-carrier and independent sideband, or ISB).

Continue....

- Calculated digital samples are converted to voltages with a digital to analog converter, typically at a frequency less than the desired RF-output frequency.
- Analog signal must then be shifted in frequency, and linearly amplified to the desired frequency and power level (linear amplification must be used to prevent modulation distortion). This low-level method for AM is used in many Amateur Radio transceivers.

High-level generation

- High-power AM transmitters (such as those used for AM broadcasting) are based on high-efficiency class-D and class-E power amplifier stages, modulated by varying the supply voltage.
- Older designs (for broadcast) also generate AM by controlling the gain of the transmitter's final amplifier (generally class-C, for efficiency). The following types are for vacuum tube transmitters (but similar options are available with transistors):

Continue....

- **Plate modulation:** In plate modulation, the plate voltage of the RF amplifier is modulated with the audio signal. The audio power requirement is 50 percent of the RF-carrier power.
- **Constant-current modulation:** RF amplifier plate voltage is fed through a “choke” (high-value inductor). The AM modulation tube plate is fed through the same inductor, so the modulator tube diverts current from the RF amplifier. The choke acts as a constant current source in the audio range. This system has a low power efficiency.

Continue ...

- **Control grid modulation:** The operating bias and gain of the final RF amplifier can be controlled by varying the voltage of the control grid. This method requires little audio power, but care must be taken to reduce distortion.
- **Clamp tube (screen grid) modulation:** The screen-grid bias may be controlled through a “clamp tube”, which reduces voltage according to the modulation signal. It is difficult to approach 100-percent modulation while maintaining low distortion with this system.

Collector Modulation

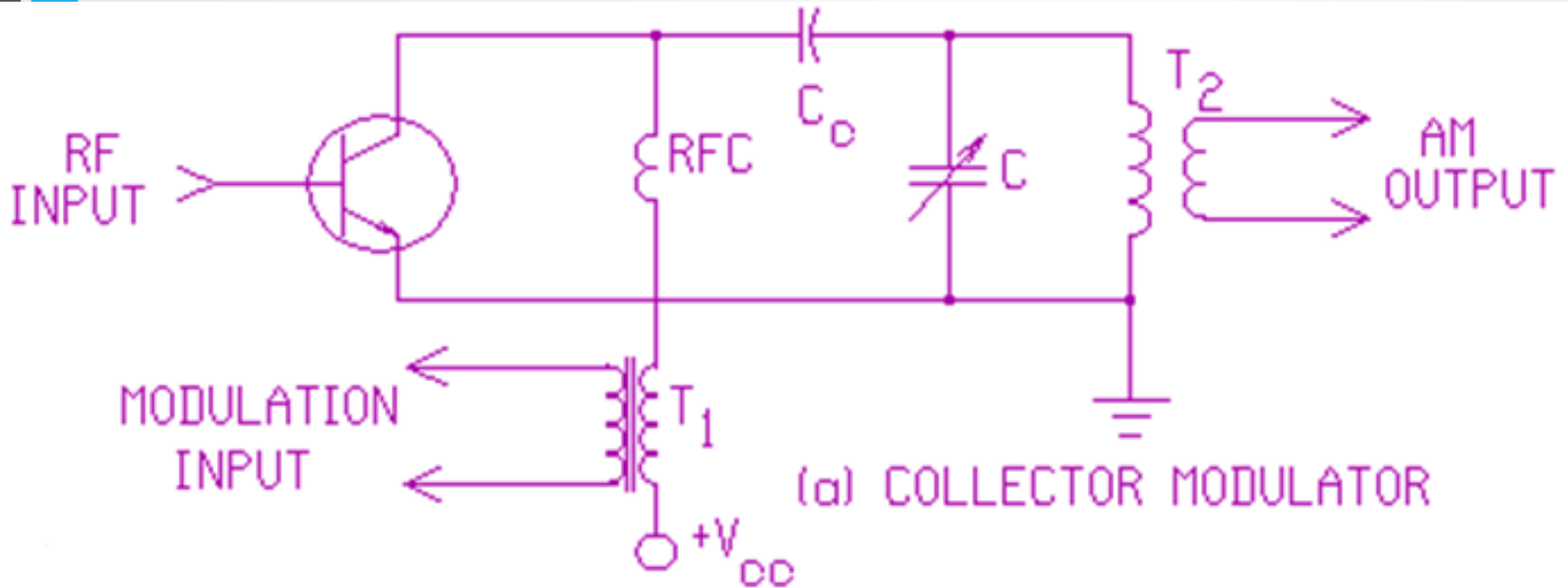

AM Demodulation

- Square law Detector
- Linear Diode (Envelope) Detector

Linear Diode detector

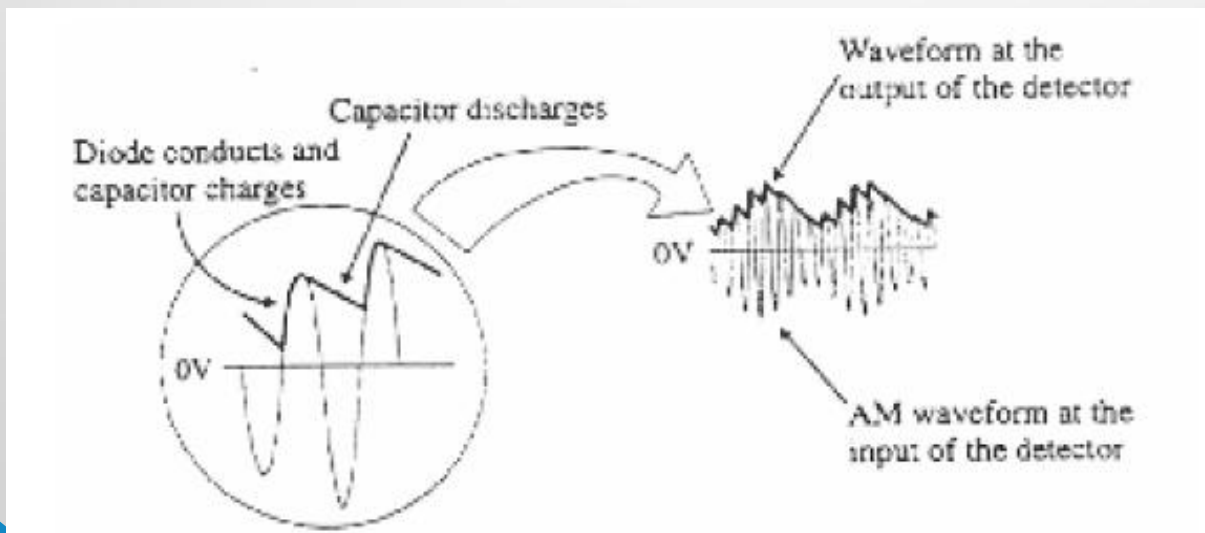
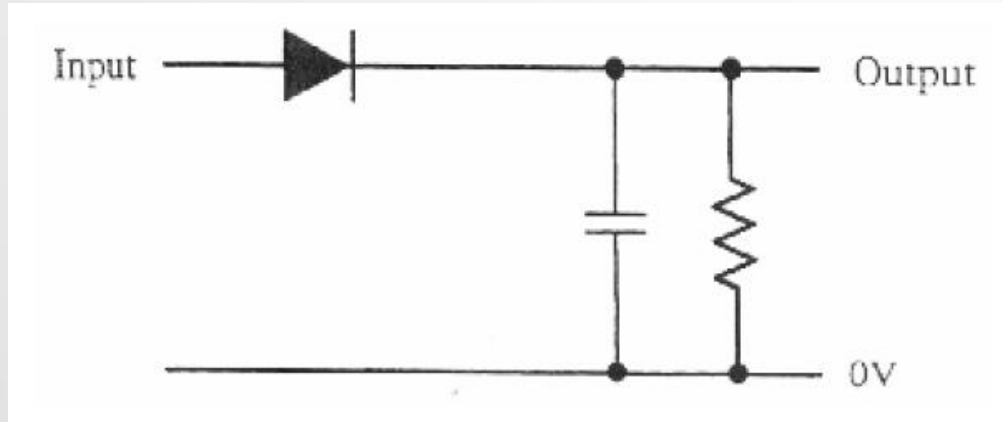

- **Linear detector** utilizes the rectification characteristic of a diode.
- The modulated carrier voltage is applied to the series combination of diode and the load impedance consisting of resistor R in shunt with capacitor C .
- Since applied voltage is of large magnitude, the operation takes place essentially over the linear region of the dynamic current-voltage characteristic of the diode.
- The idealized linear dynamic current-voltage characteristic of the diode detector. Assuming capacitor C to be absent, the total impedance in series circuit is $(r_a + R)$ where r_a is the dynamic anode resistance of the diode.

- Modulated carrier voltage then yields output of the form. The diode conducts during the positive half of the carrier cycle but does not conduct during the negative half.
- The presence of the shunt capacitor C modifies the output. During the positive half carrier cycle, diode conduct thereby charging the capacitor C , in the polarity shown, to the peak value of the carrier voltage.
- During the negative half of the carrier cycle, the diode does not conduct and hence the capacitor C discharges through the resistor R .

- O/P voltage curve is of spiky nature but it almost traces the envelope of the modulated carrier voltage and hence it is nothing but the original modulation voltage
- The departure of this output voltage from the envelope may be reduced by proper choice of R and C depending upon the modulation frequency and depth of modulation



The input to the diode detector from the last IF amplifier

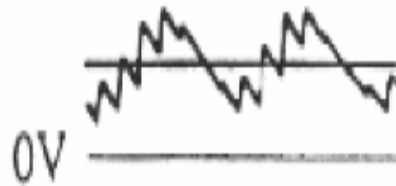

Output of diode detector includes : a DC level, the audio signal, ripple at IF frequency



Output after filtering