

Internet Fundamentals

Lecture-10

- IPv4

19-1 IPv4 ADDRESSES

*An **IPv4 address** is a **32-bit** address that uniquely and universally defines the connection of a device (for example, a computer or a router) to the Internet.*

Topics discussed in this section:

Address Space

Notations

Classful Addressing

Classless Addressing

Network Address Translation (NAT)



Note

An IPv4 address is 32 bits long.



Note

**The IPv4 addresses are unique
and universal.**



Note

**The address space of IPv4 is
 2^{32} or 4,294,967,296.**

Figure 19.1 *Dotted-decimal notation and binary notation for an IPv4 address*

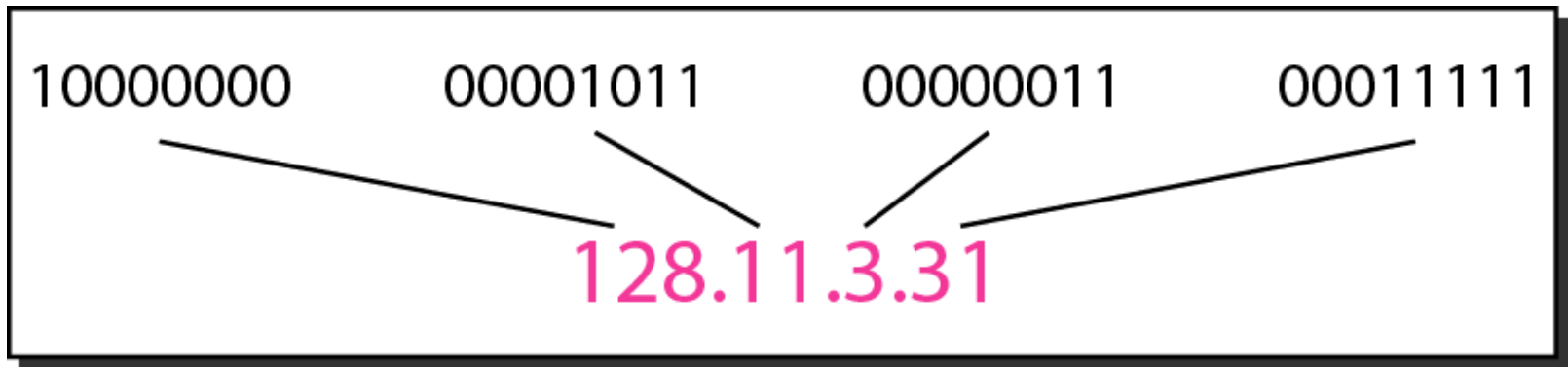



Note

**Numbering systems are reviewed in
Appendix B.**

Example 19.1

Change the following IPv4 addresses from binary notation to dotted-decimal notation.

a. 10000001 00001011 00001011 11101111

b. 11000001 10000011 00011011 11111111

Solution

We replace each group of 8 bits with its equivalent decimal number (see Appendix B) and add dots for separation.

a. 129.11.11.239

b. 193.131.27.255



Example 19.2

Change the following IPv4 addresses from dotted-decimal notation to binary notation.

a. 111.56.45.78

b. 221.34.7.82

Solution

We replace each decimal number with its binary equivalent (see Appendix B).

a. 01101111 00111000 00101101 01001110

b. 11011101 00100010 00000111 01010010



Example 19.3

Find the error, if any, in the following IPv4 addresses.

- a. 111.56.045.78
- b. 221.34.7.8.20
- c. 75.45.301.14
- d. 11100010.23.14.67

Solution

- a. There must be no leading zero (045).*
- b. There can be no more than four numbers.*
- c. Each number needs to be less than or equal to 255.*
- d. A mixture of binary notation and dotted-decimal notation is not allowed.*



Note

**In classful addressing, the address space is divided into five classes:
A, B, C, D, and E.**

Figure 19.2 *Finding the classes in binary and dotted-decimal notation*

	First byte	Second byte	Third byte	Fourth byte
Class A	0			
Class B	10			
Class C	110			
Class D	1110			
Class E	1111			

a. Binary notation

	First byte	Second byte	Third byte	Fourth byte
Class A	0-127			
Class B	128-191			
Class C	192-223			
Class D	224-239			
Class E	240-255			

b. Dotted-decimal notation

Example 19.4

Find the class of each address.

- a.* 00000001 00001011 00001011 11101111
- b.* 11000001 10000011 00011011 11111111
- c.* 14.23.120.8
- d.* 252.5.15.111

Solution

- a.* *The first bit is 0. This is a class A address.*
- b.* *The first 2 bits are 1; the third bit is 0. This is a class C address.*
- c.* *The first byte is 14; the class is A.*
- d.* *The first byte is 252; the class is E.*

Table 19.1 *Number of blocks and block size in classful IPv4 addressing*

<i>Class</i>	<i>Number of Blocks</i>	<i>Block Size</i>	<i>Application</i>
A	128	16,777,216	Unicast
B	16,384	65,536	Unicast
C	2,097,152	256	Unicast
D	1	268,435,456	Multicast
E	1	268,435,456	Reserved



Note

In classful addressing, a large part of the available addresses were wasted.

Table 19.2 *Default masks for classful addressing*

<i>Class</i>	<i>Binary</i>	<i>Dotted-Decimal</i>	<i>CIDR</i>
A	11111111 00000000 00000000 00000000	255.0.0.0	/8
B	11111111 11111111 00000000 00000000	255.255.0.0	/16
C	11111111 11111111 11111111 00000000	255.255.255.0	/24



Note

Classful addressing, which is almost obsolete, is replaced with classless addressing.



Example 19.5

Figure 19.3 shows a block of addresses, in both binary and dotted-decimal notation, granted to a small business that needs 16 addresses.

We can see that the restrictions are applied to this block. The addresses are contiguous. The number of addresses is a power of 2 ($16 = 2^4$), and the first address is divisible by 16. The first address, when converted to a decimal number, is 3,440,387,360, which when divided by 16 results in 215,024,210.

Figure 19.3 *A block of 16 addresses granted to a small organization*

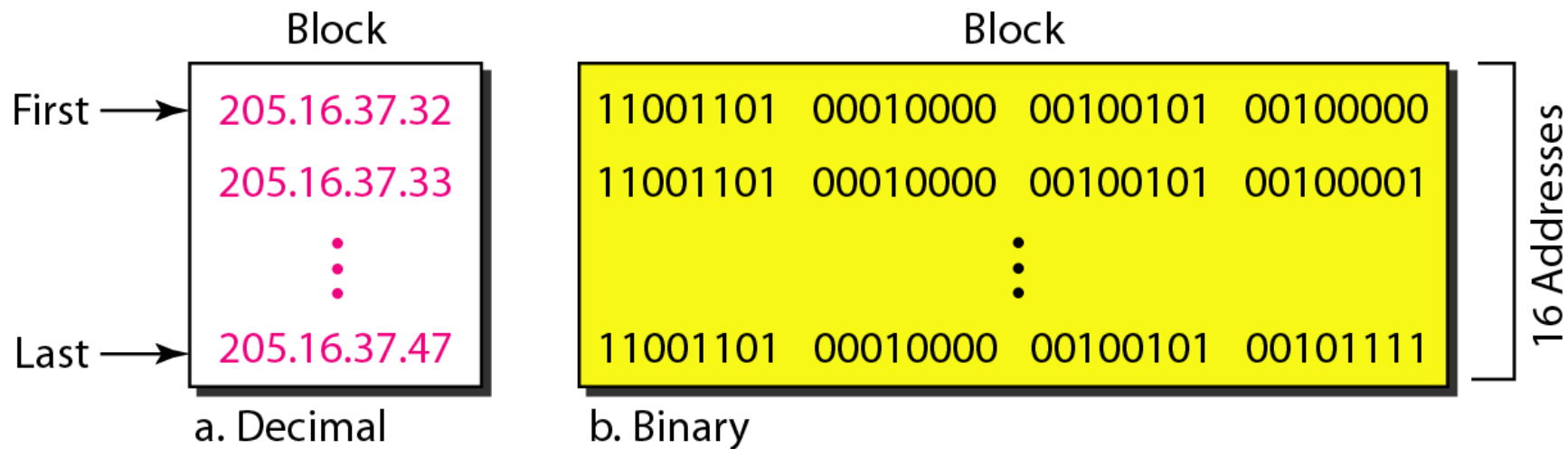



Note

In IPv4 addressing, a block of addresses can be defined as

$x.y.z.t /n$

in which $x.y.z.t$ defines one of the addresses and the $/n$ defines the mask.



Note

The first address in the block can be found by setting the rightmost $32 - n$ bits to 0s.

Example 19.6

A block of addresses is granted to a small organization. We know that one of the addresses is 205.16.37.39/28. What is the first address in the block?

Solution

The binary representation of the given address is

11001101 00010000 00100101 00100111

If we set 32–28 rightmost bits to 0, we get

11001101 00010000 00100101 00100000

or

205.16.37.32.

This is actually the block shown in Figure 19.3.



Note

The last address in the block can be found by setting the rightmost $32 - n$ bits to 1s.



Example 19.7

Find the last address for the block in Example 19.6.

Solution

The binary representation of the given address is

11001101 00010000 00100101 00100111

If we set 32 – 28 rightmost bits to 1, we get

11001101 00010000 00100101 00101111

or

205.16.37.47

This is actually the block shown in Figure 19.3.



Note

**The number of addresses in the block
can be found by using the formula
 2^{32-n} .**



Example 19.8

Find the number of addresses in Example 19.6.

Solution

The value of n is 28, which means that number of addresses is 2^{32-28} or 16.

Example 19.9

Another way to find the first address, the last address, and the number of addresses is to represent the mask as a 32-bit binary (or 8-digit hexadecimal) number. This is particularly useful when we are writing a program to find these pieces of information. In Example 19.5 the /28 can be represented as

11111111 11111111 11111111 11110000

(twenty-eight 1s and four 0s).

Find

- a. The first address*
- b. The last address*
- c. The number of addresses.*

Example 19.9 (continued)

Solution

- a. The first address can be found by ANDing the given addresses with the mask. ANDing here is done bit by bit. The result of ANDing 2 bits is 1 if both bits are 1s; the result is 0 otherwise.*

Address:	11001101	00010000	00100101	00100111
Mask:	11111111	11111111	11111111	11110000
First address:	11001101	00010000	00100101	00100000

Example 19.9 (continued)

- b. The last address can be found by ORing the given addresses with the complement of the mask. ORing here is done bit by bit. The result of ORing 2 bits is 0 if both bits are 0s; the result is 1 otherwise. The complement of a number is found by changing each 1 to 0 and each 0 to 1.*

Address:	11001101	00010000	00100101	00100111
Mask complement:	00000000	00000000	00000000	00001111
Last address:	11001101	00010000	00100101	00101111

Example 19.9 (continued)

- c. The number of addresses can be found by complementing the mask, interpreting it as a decimal number, and adding 1 to it.*

Mask complement:	00000000	00000000	00000000	00001111
Number of addresses:	$15 + 1 = 16$			

Figure 19.4 *A network configuration for the block 205.16.37.32/28*

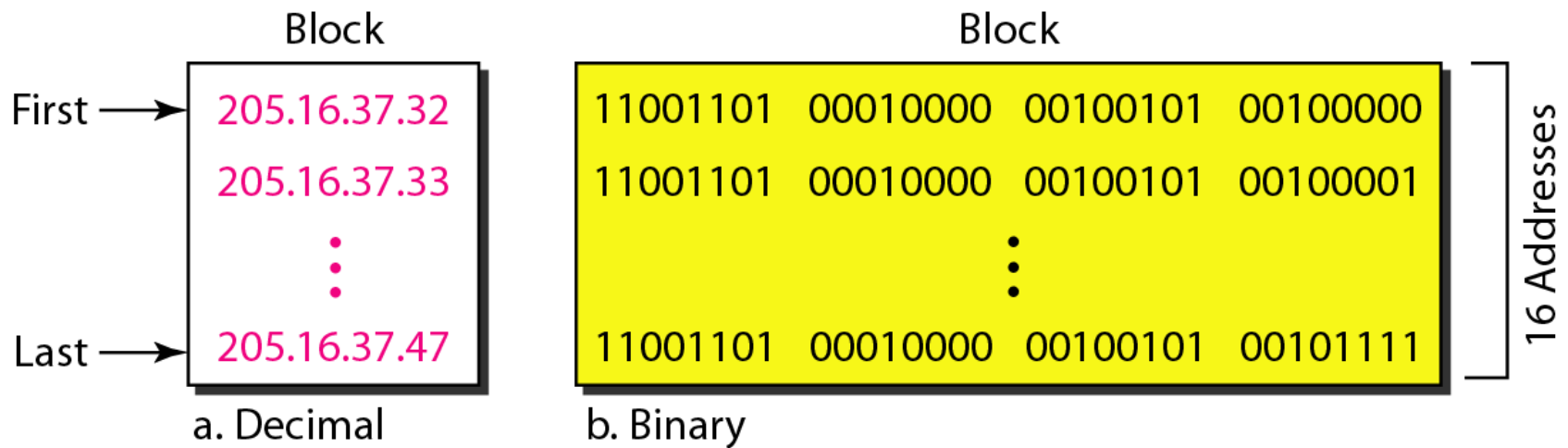



Note

The first address in a block is normally not assigned to any device; it is used as the network address that represents the organization to the rest of the world.

Figure 19.5 *Two levels of hierarchy in an IPv4 address*

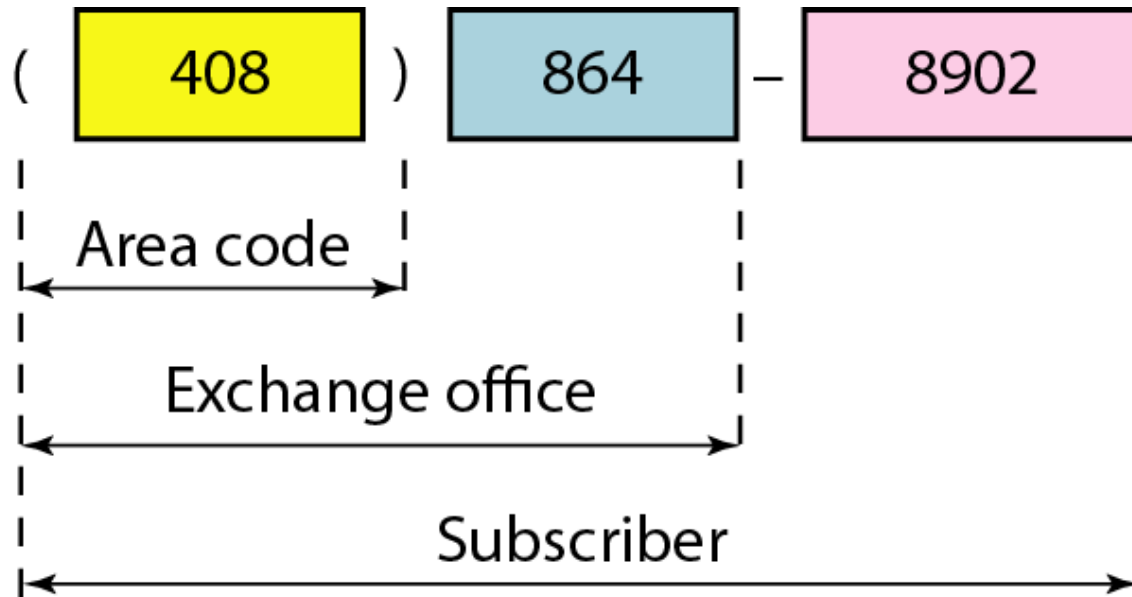
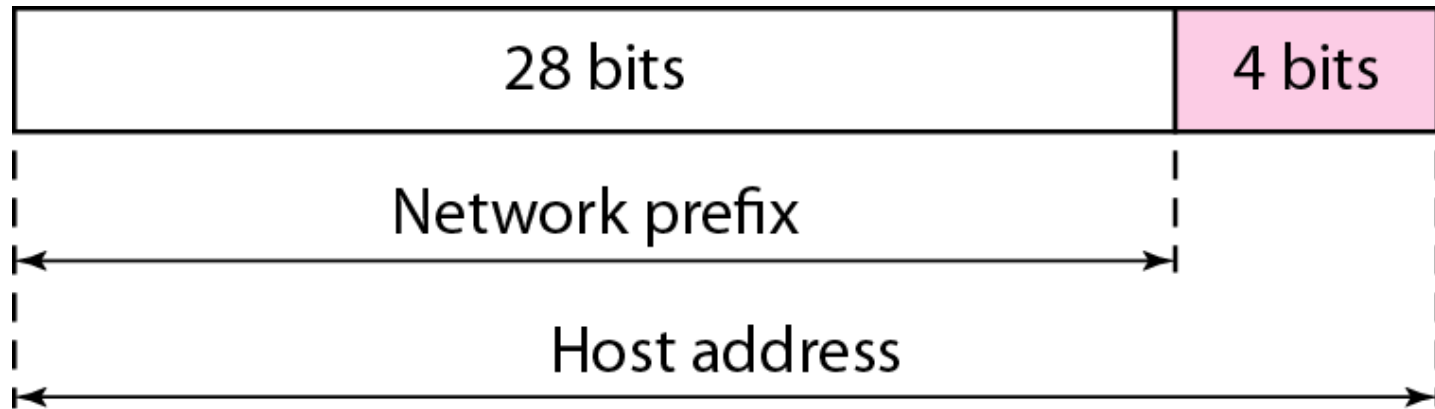

Figure 19.6 *A frame in a character-oriented protocol*





Note

**Each address in the block can be considered as a two-level hierarchical structure:
the leftmost n bits (prefix) define the network;
the rightmost $32 - n$ bits define the host.**

Figure 19.7 *Configuration and addresses in a subnetted network*

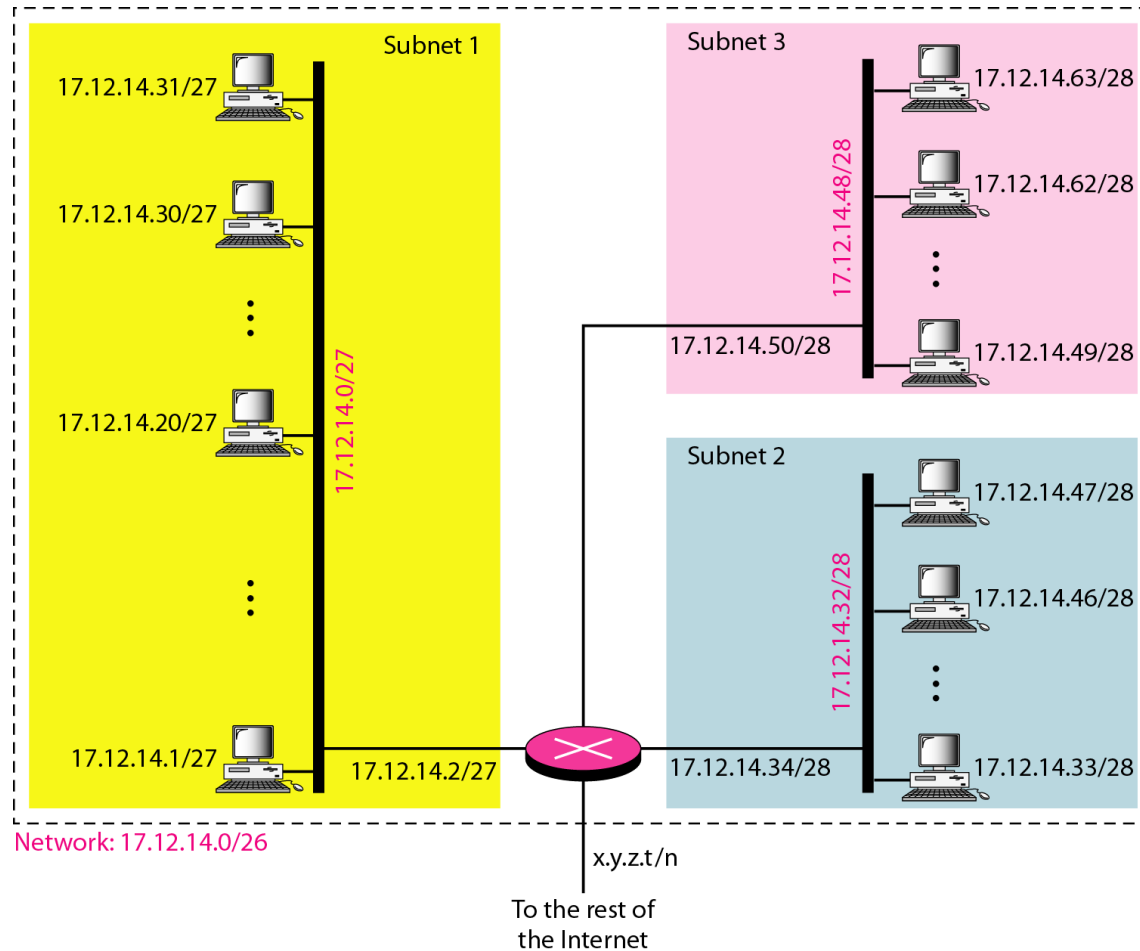
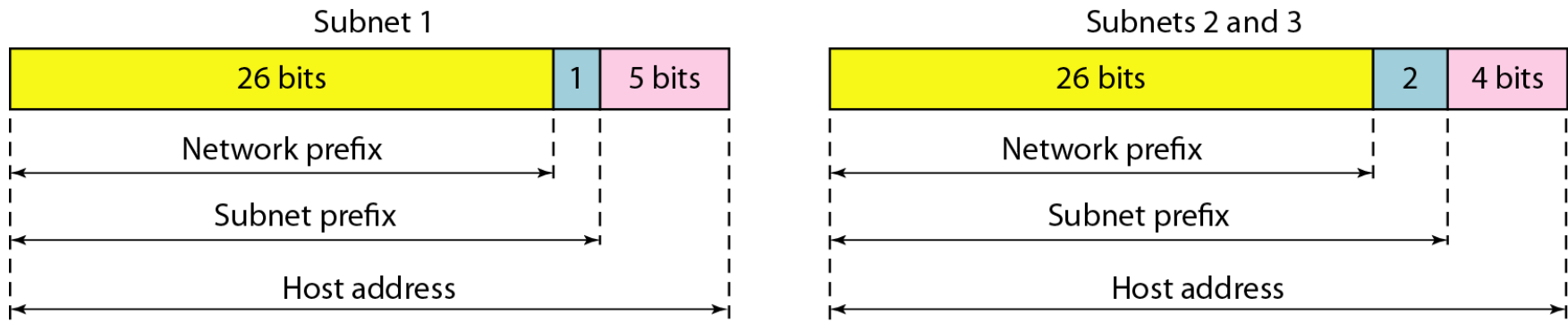

Figure 19.8 *Three-level hierarchy in an IPv4 address*





Example 19.10

An ISP is granted a block of addresses starting with 190.100.0.0/16 (65,536 addresses). The ISP needs to distribute these addresses to three groups of customers as follows:

- a. The first group has 64 customers; each needs 256 addresses.*
- b. The second group has 128 customers; each needs 128 addresses.*
- c. The third group has 128 customers; each needs 64 addresses.*

Design the subblocks and find out how many addresses are still available after these allocations.

Example 19.10 (continued)

Solution

Figure 19.9 shows the situation.

Group 1

For this group, each customer needs 256 addresses. This means that 8 ($\log_2 256$) bits are needed to define each host. The prefix length is then $32 - 8 = 24$. The addresses are

<i>1st Customer:</i>	<i>190.100.0.0/24</i>	<i>190.100.0.255/24</i>
<i>2nd Customer:</i>	<i>190.100.1.0/24</i>	<i>190.100.1.255/24</i>
<i>...</i>		
<i>64th Customer:</i>	<i>190.100.63.0/24</i>	<i>190.100.63.255/24</i>
<i>Total = $64 \times 256 = 16,384$</i>		

Example 19.10 (continued)

Group 2

For this group, each customer needs 128 addresses. This means that 7 ($\log_2 128$) bits are needed to define each host. The prefix length is then $32 - 7 = 25$. The addresses are

<i>1st Customer:</i>	<i>190.100.64.0/25</i>	<i>190.100.64.127/25</i>
<i>2nd Customer:</i>	<i>190.100.64.128/25</i>	<i>190.100.64.255/25</i>
<i>...</i>		
<i>128th Customer:</i>	<i>190.100.127.128/25</i>	<i>190.100.127.255/25</i>
<i>Total = $128 \times 128 = 16,384$</i>		

Example 19.10 (continued)

Group 3

For this group, each customer needs 64 addresses. This means that 6 ($\log_2 64$) bits are needed to each host. The prefix length is then $32 - 6 = 26$. The addresses are

<i>1st Customer:</i>	<i>190.100.128.0/26</i>	<i>190.100.128.63/26</i>
<i>2nd Customer:</i>	<i>190.100.128.64/26</i>	<i>190.100.128.127/26</i>
<i>...</i>		
<i>128th Customer:</i>	<i>190.100.159.192/26</i>	<i>190.100.159.255/26</i>
<i>Total =</i>	<i>$128 \times 64 = 8192$</i>	

Number of granted addresses to the ISP: 65,536

Number of allocated addresses by the ISP: 40,960

Number of available addresses: 24,576

Figure 19.9 *An example of address allocation and distribution by an ISP*

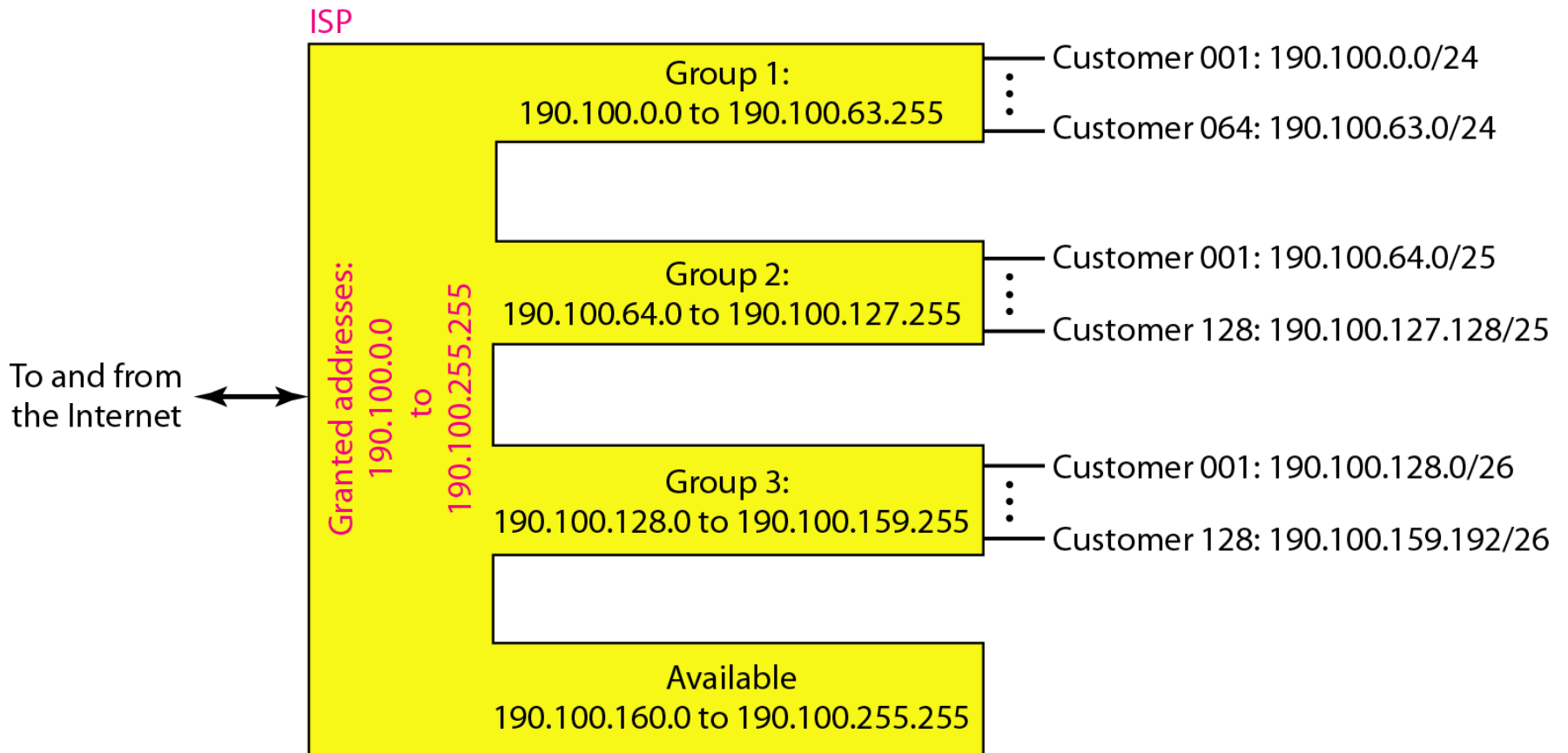

Table 19.3 *Addresses for private networks*

<i>Range</i>			<i>Total</i>
10.0.0.0	to	10.255.255.255	2^{24}
172.16.0.0	to	172.31.255.255	2^{20}
192.168.0.0	to	192.168.255.255	2^{16}

Figure 19.10 *A NAT implementation*

Site using private addresses

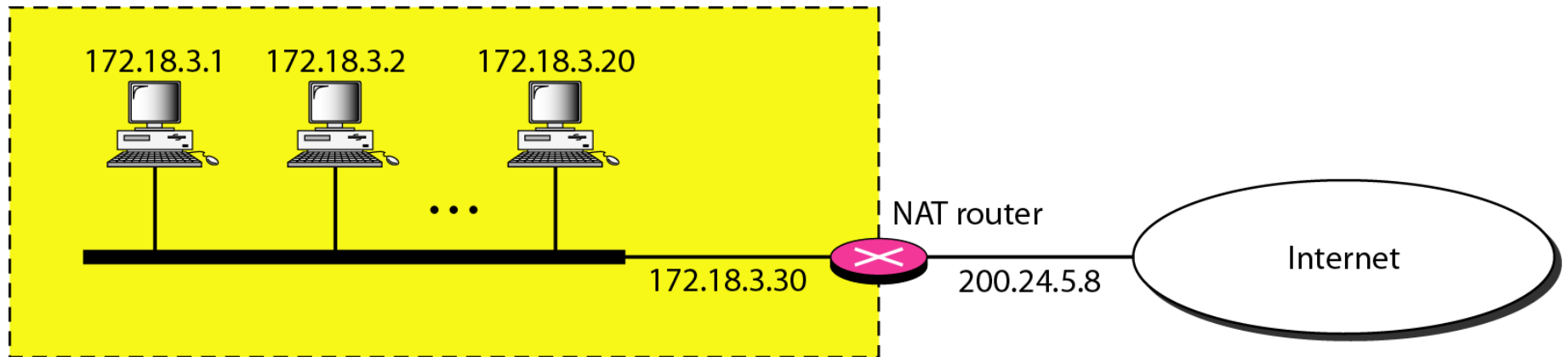

Figure 19.11 *Addresses in a NAT*

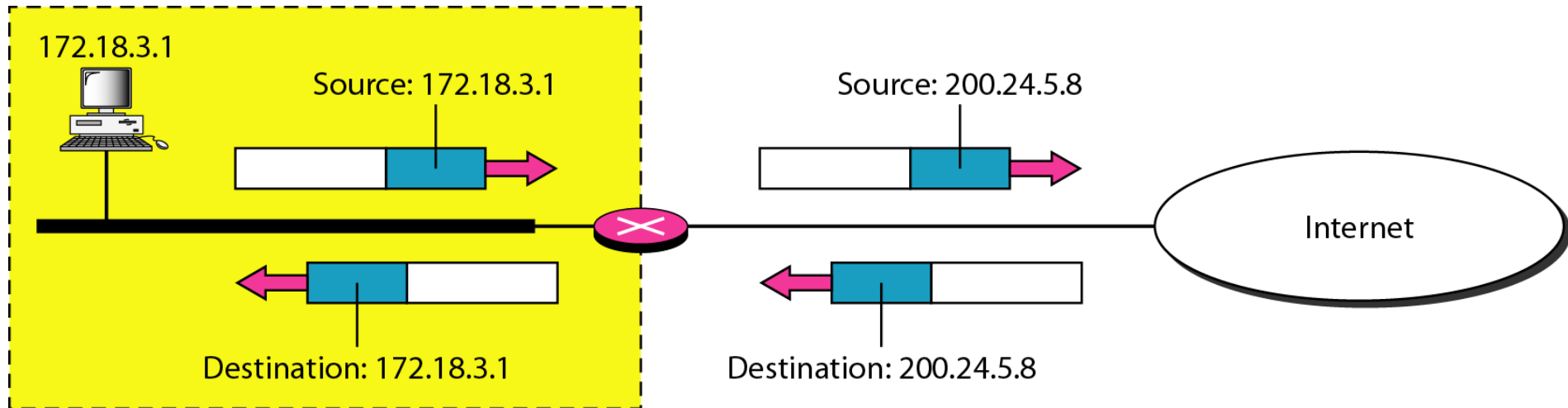

Figure 19.12 NAT address translation

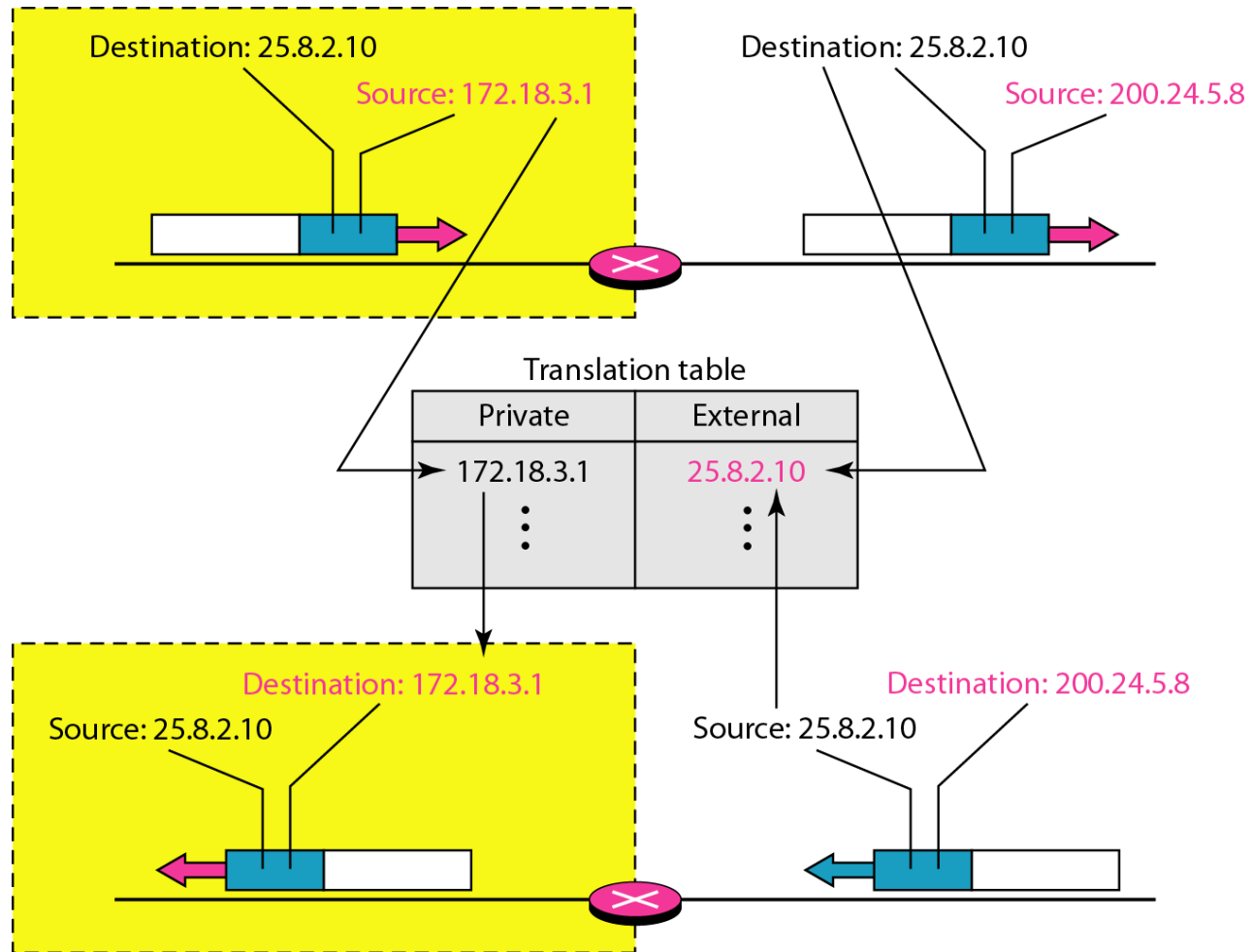
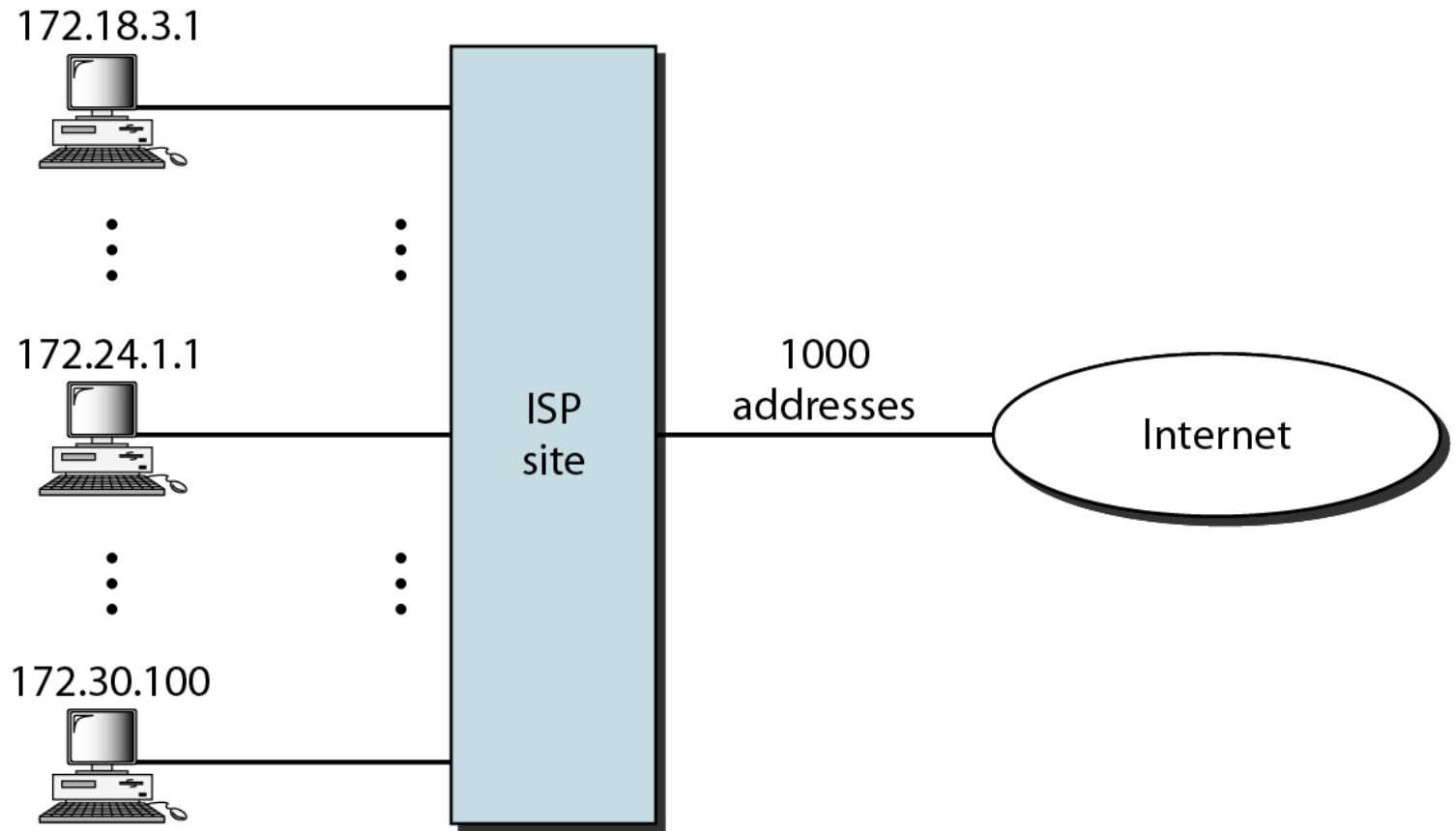

Table 19.4 *Five-column translation table*

<i>Private Address</i>	<i>Private Port</i>	<i>External Address</i>	<i>External Port</i>	<i>Transport Protocol</i>
172.18.3.1	1400	25.8.3.2	80	TCP
172.18.3.2	1401	25.8.3.2	80	TCP
...

Figure 19.13 *An ISP and NAT*



19-2 IPv6 ADDRESSES

Despite all short-term solutions, address depletion is still a long-term problem for the Internet. This and other problems in the IP protocol itself have been the motivation for IPv6.

Topics discussed in this section:

Structure

Address Space



Note

An IPv6 address is 128 bits long.

Figure 19.14 *IPv6 address in binary and hexadecimal colon notation*

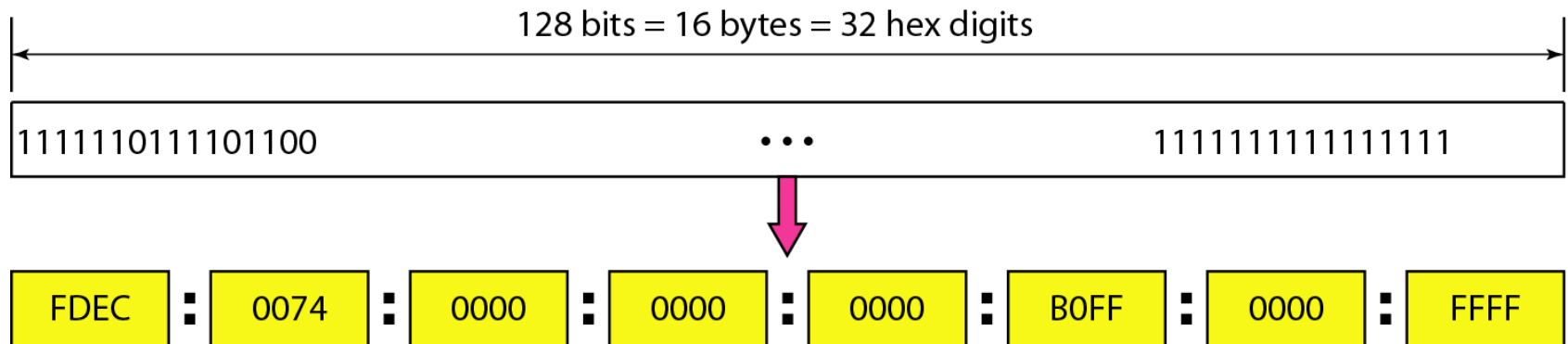
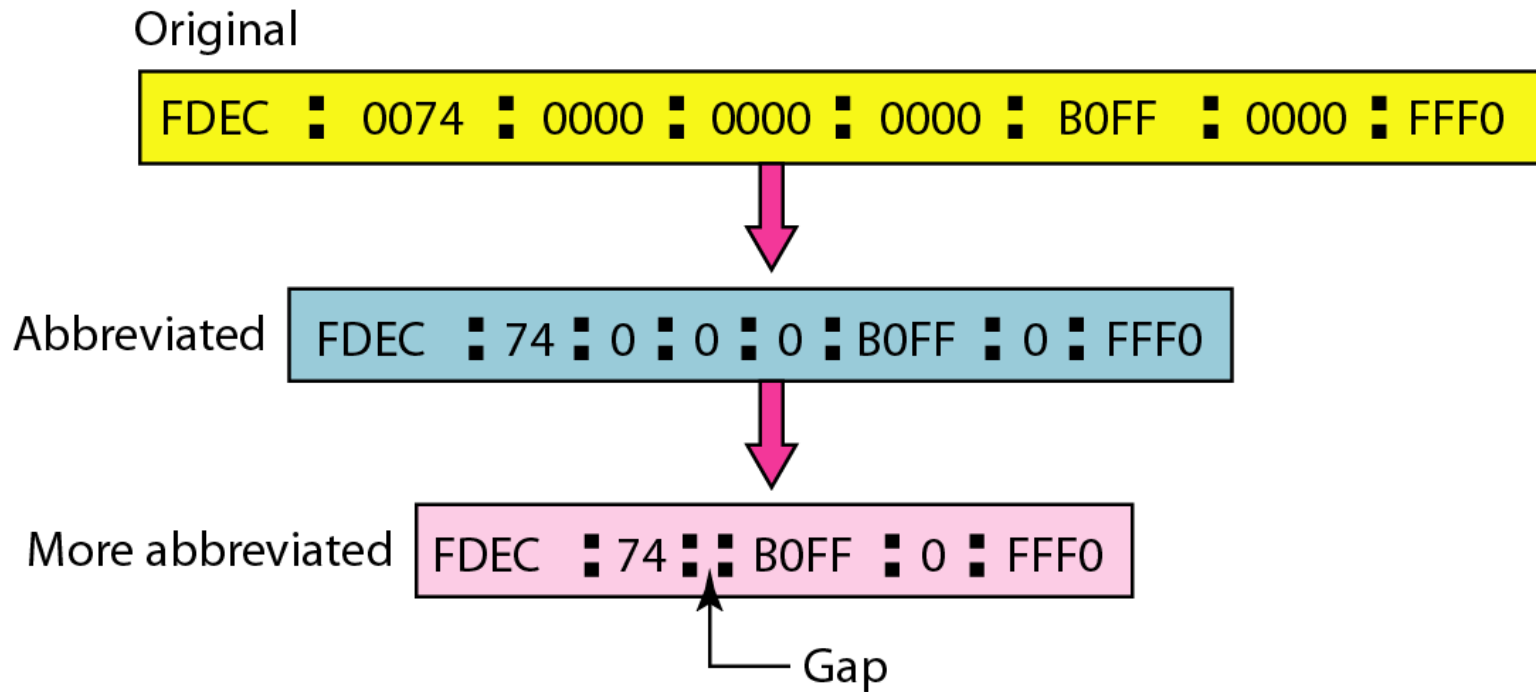

Figure 19.15 *Abbreviated IPv6 addresses*



Example 19.11

Expand the address 0:15::1:12:1213 to its original.

Solution

We first need to align the left side of the double colon to the left of the original pattern and the right side of the double colon to the right of the original pattern to find how many 0s we need to replace the double colon.

```
XXXX:XXXX:XXXX:XXXX:XXXX:XXXX:XXXX:XXXX  
0: 15:           : 1: 12:1213
```

This means that the original address is.

```
0000:0015:0000:0000:0000:0001:0012:1213
```

Table 19.5 *Type prefixes for IPv6 addresses*

<i>Type Prefix</i>	<i>Type</i>	<i>Fraction</i>
0000 0000	Reserved	1/256
0000 0001	Unassigned	1/256
0000 001	ISO network addresses	1/128
0000 010	IPX (Novell) network addresses	1/128
0000 011	Unassigned	1/128
0000 1	Unassigned	1/32
0001	Reserved	1/16
001	Reserved	1/8
010	Provider-based unicast addresses	1/8

Table 19.5 *Type prefixes for IPv6 addresses (continued)*

<i>Type Prefix</i>	<i>Type</i>	<i>Fraction</i>
011	Unassigned	1/8
100	Geographic-based unicast addresses	1/8
101	Unassigned	1/8
110	Unassigned	1/8
1110	Unassigned	1/16
1111 0	Unassigned	1/32
1111 10	Unassigned	1/64
1111 110	Unassigned	1/128
1111 1110 0	Unassigned	1/512
1111 1110 10	Link local addresses	1/1024
1111 1110 11	Site local addresses	1/1024
1111 1111	Multicast addresses	1/256

Figure 19.16 *Prefixes for provider-based unicast address*

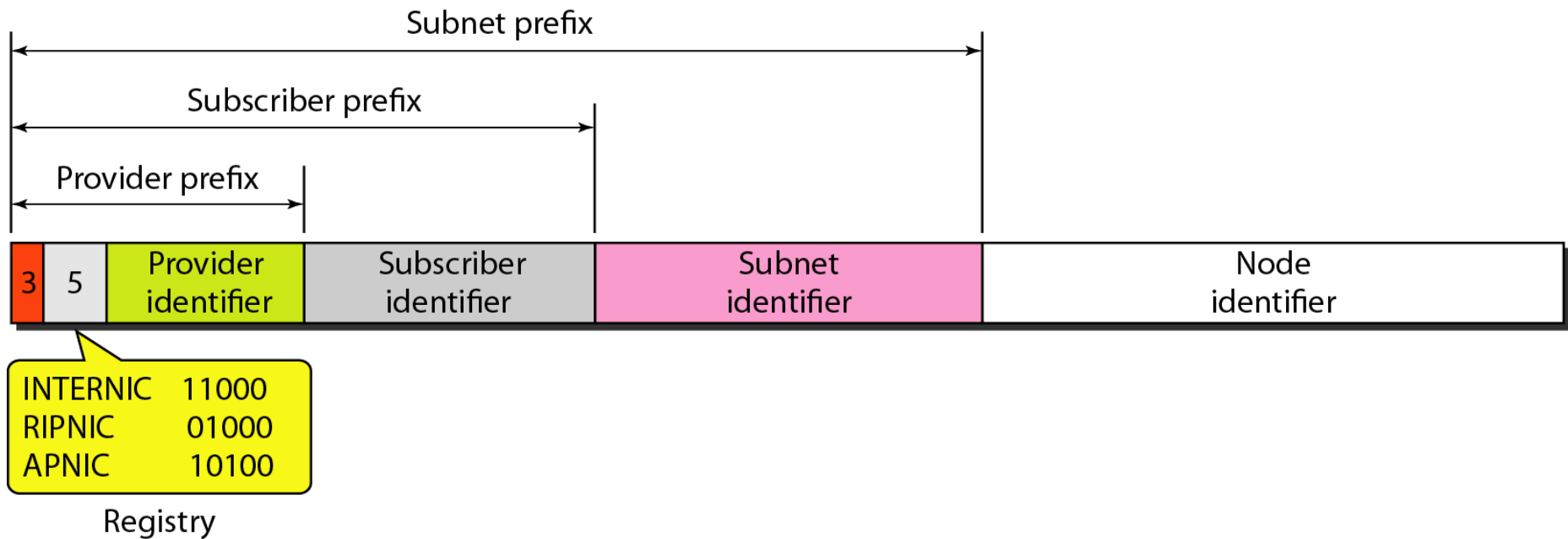

Figure 19.17 *Multicast address in IPv6*

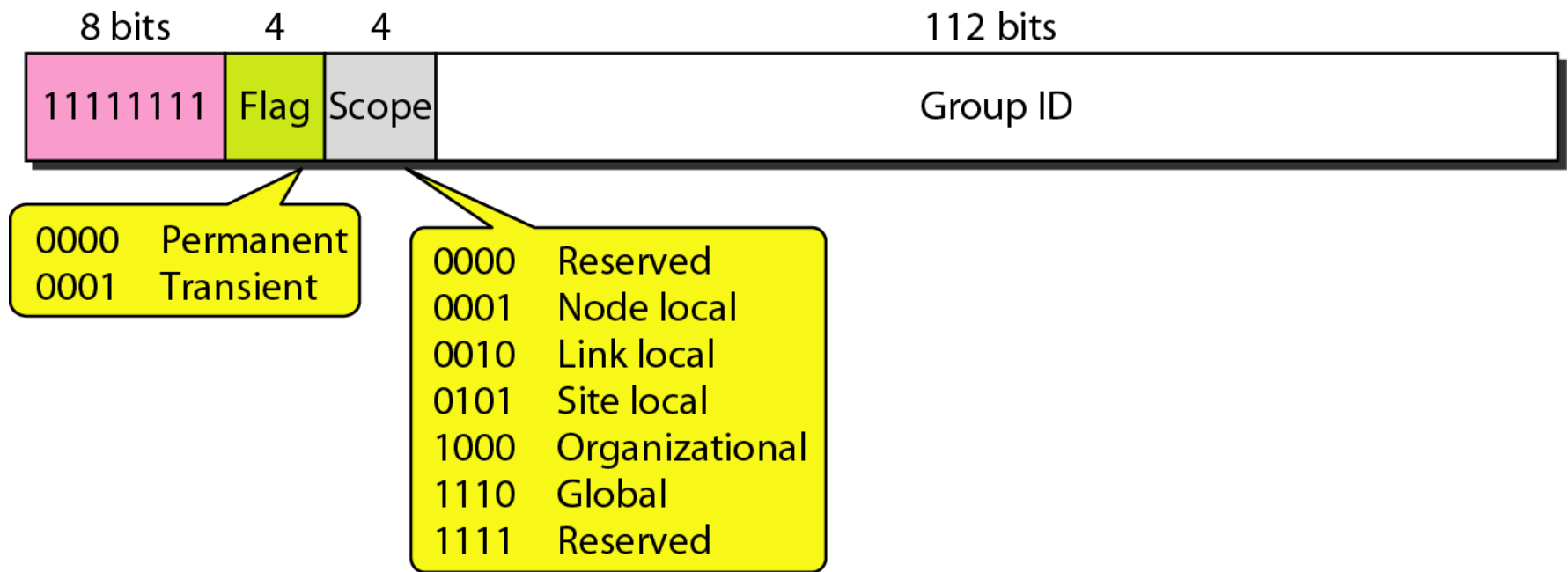

Figure 19.18 *Reserved addresses in IPv6*

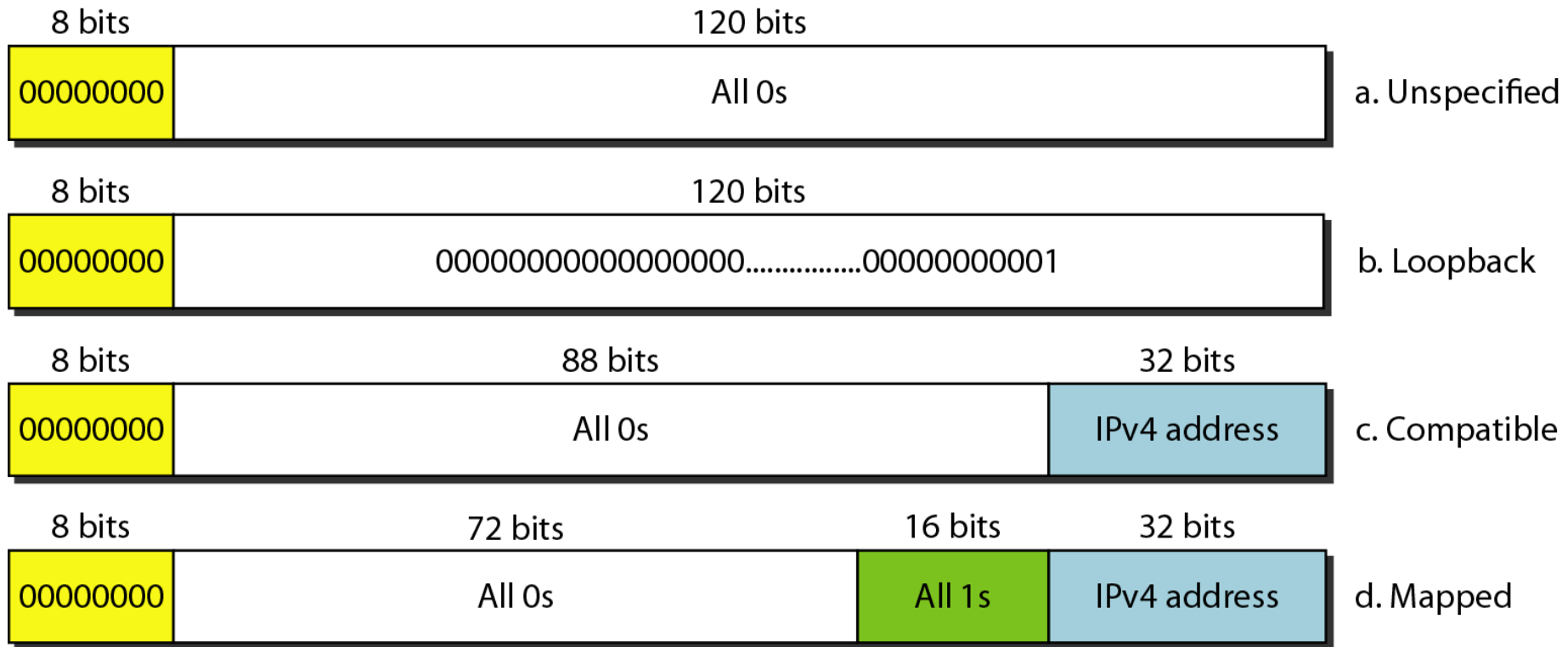

Figure 19.19 *Local addresses in IPv6*

