

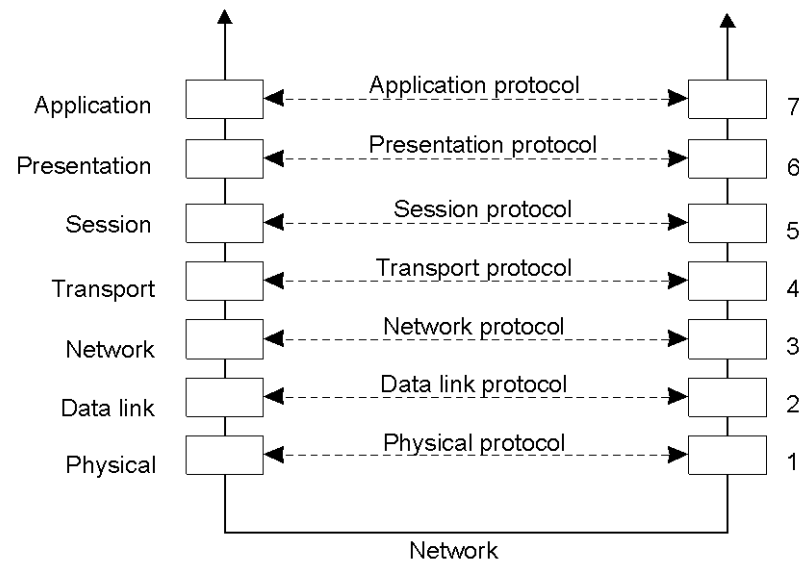

Communication

Layered Protocols (1)

Layers, interfaces, and protocols in the OSI model.



Layered Protocols (2)

A typical message as it appears on the network.

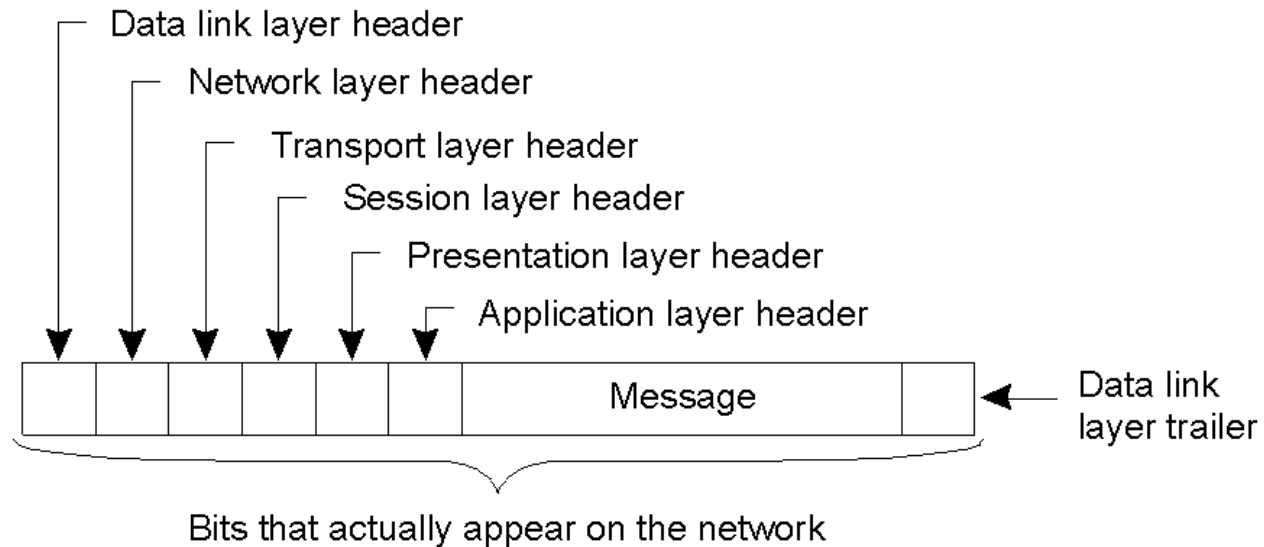

Data Link Layer

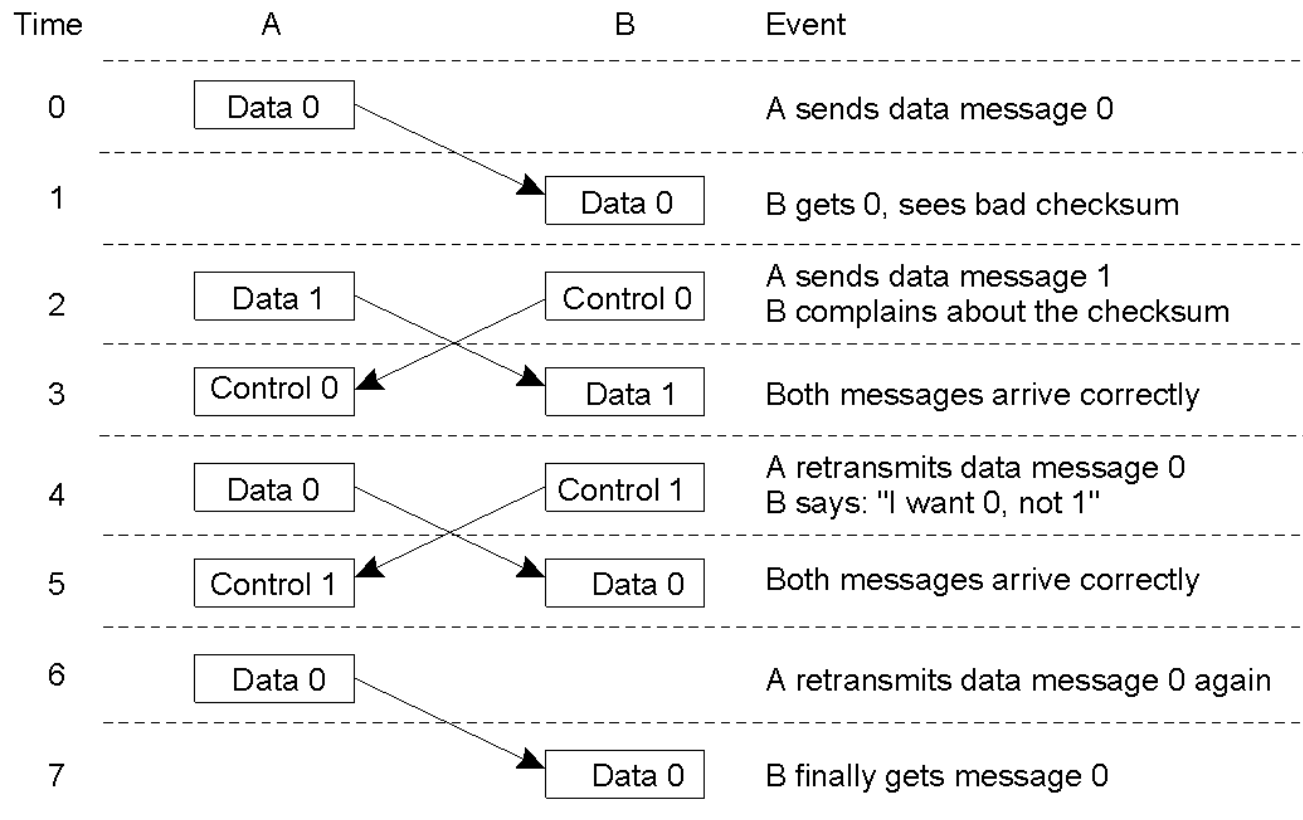

Discussion between a receiver and a sender in the data link layer.

Client-Server TCP

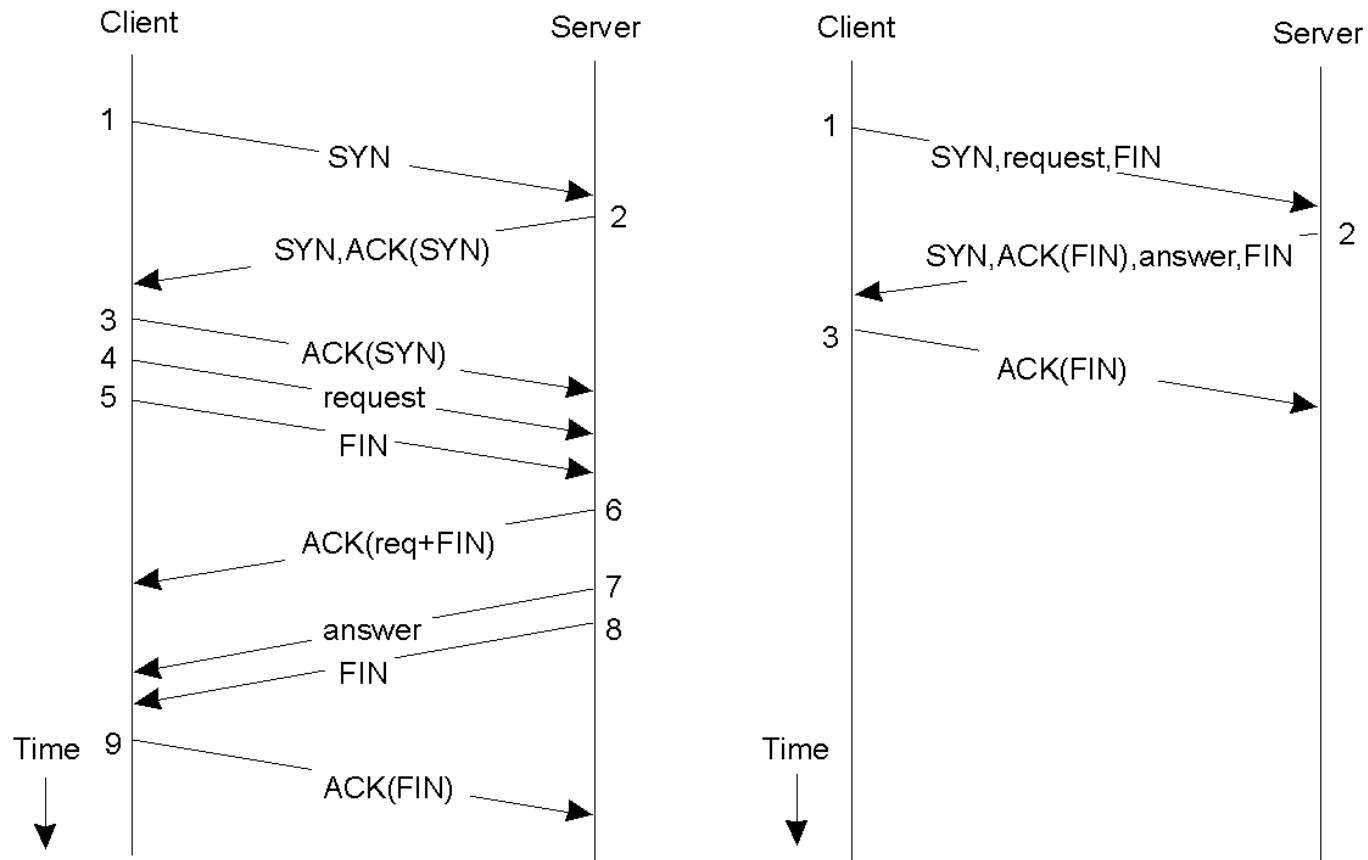

(a)

(b)

- a) Normal operation of TCP.
- b) Transactional TCP.

Middleware Protocols

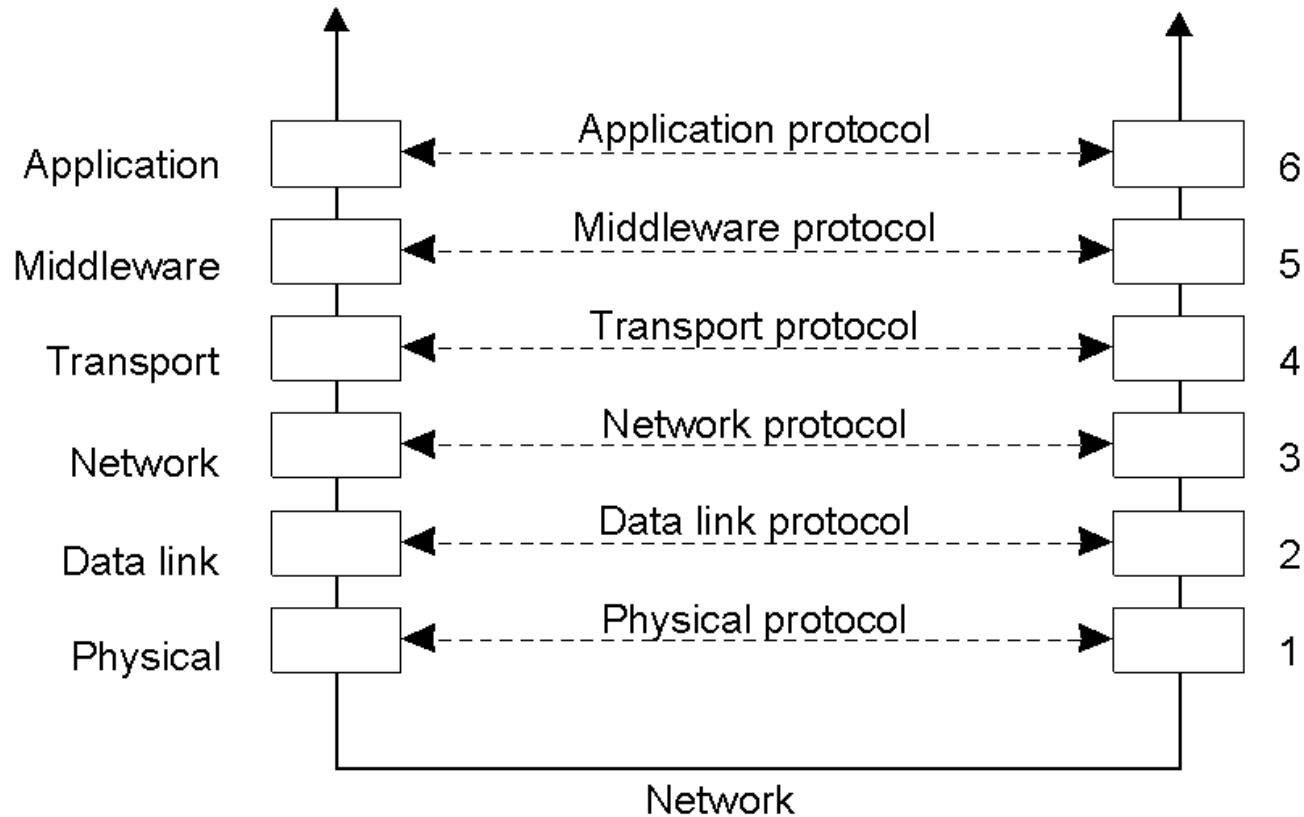

An adapted reference model for networked communication.

Conventional Procedure Call

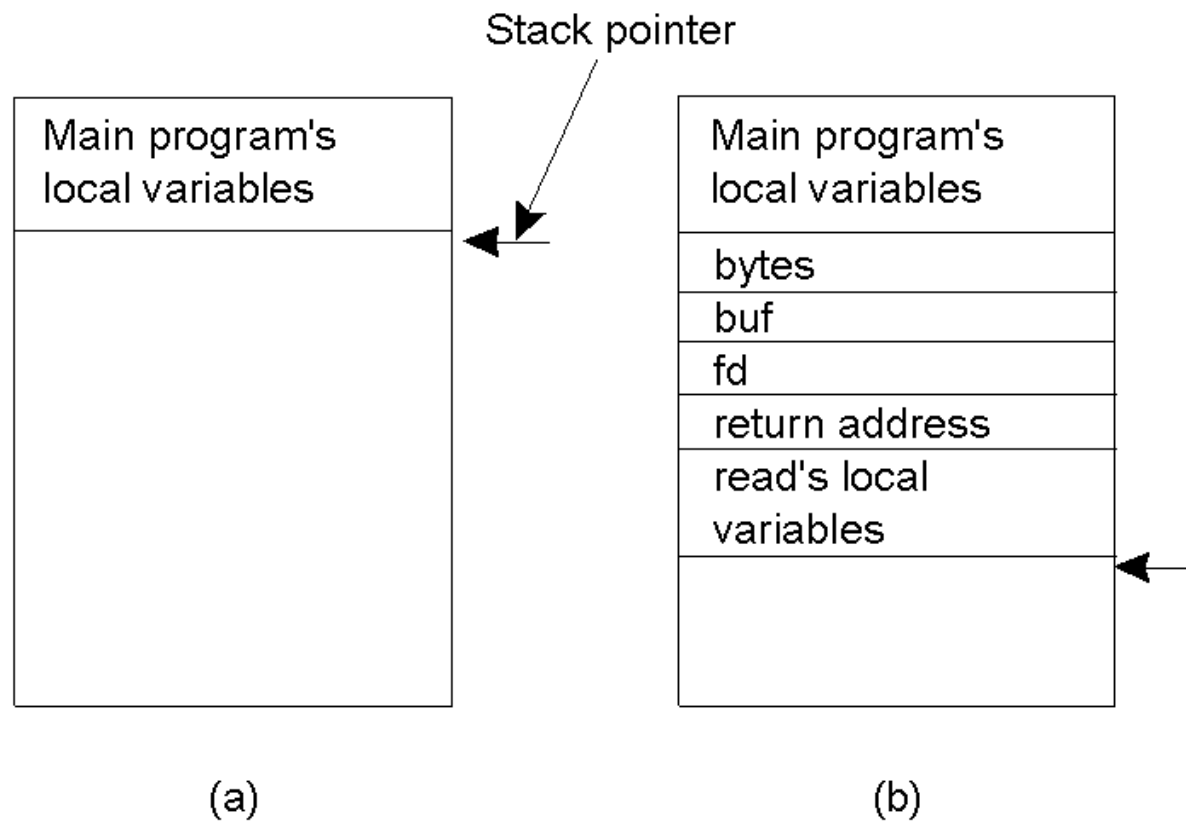

- a) Parameter passing in a local procedure call: the stack before the call to read
- b) The stack while the called procedure is active

Client and Server Stubs

Principle of RPC between a client and server program.

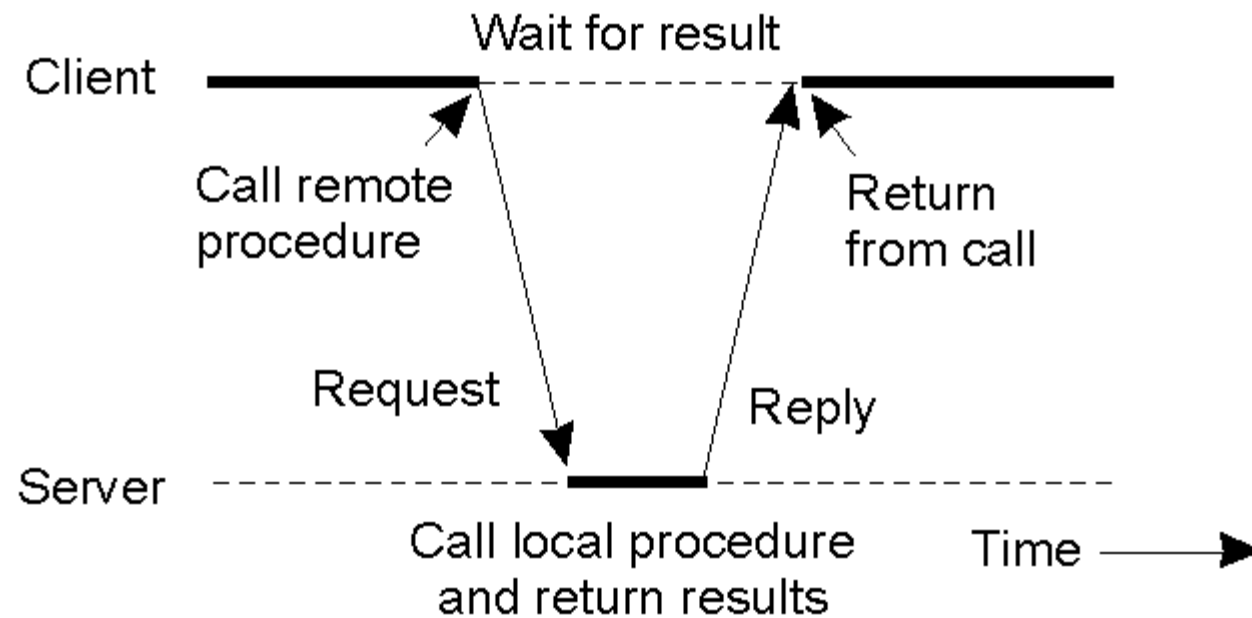

Steps of a Remote Procedure Call

1. Client procedure calls client stub in normal way
2. Client stub builds message, calls local OS
3. Client's OS sends message to remote OS
4. Remote OS gives message to server stub
5. Server stub unpacks parameters, calls server
6. Server does work, returns result to the stub
7. Server stub packs it in message, calls local OS
8. Server's OS sends message to client's OS
9. Client's OS gives message to client stub
10. Stub unpacks result, returns to client

Passing Value Parameters (1)

Steps involved in doing remote computation through RPC

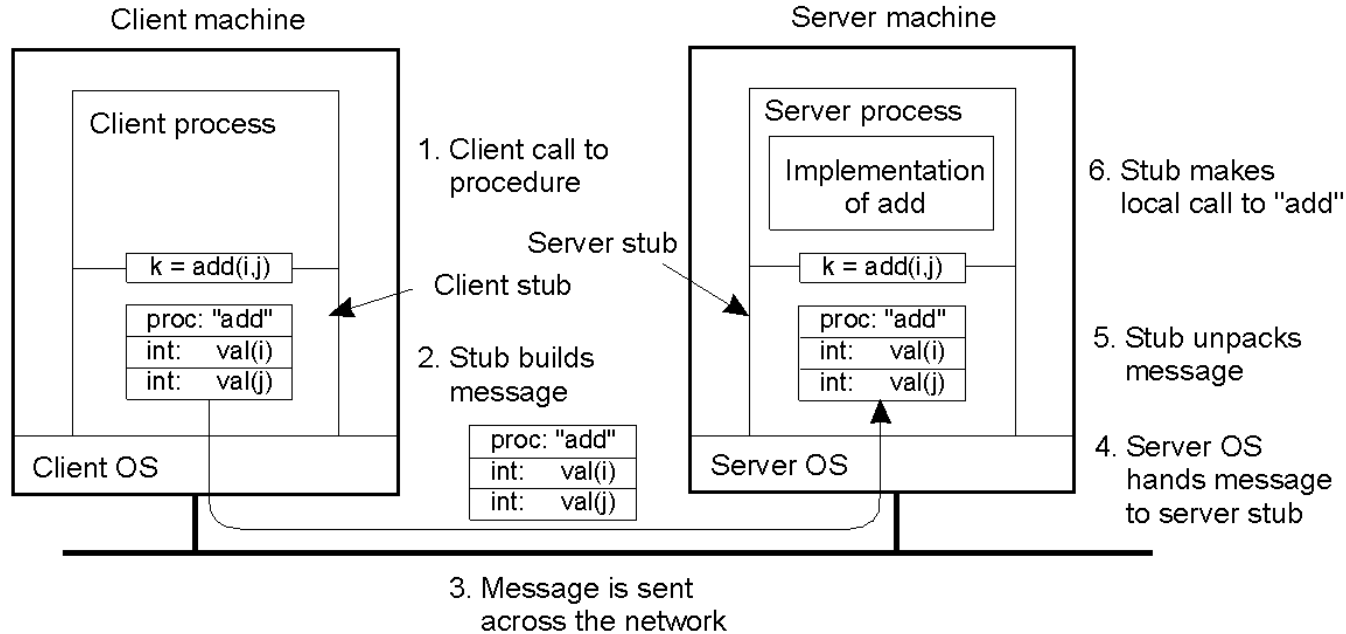

Passing Value Parameters (2)

3	2	1	0
0	0	0	5
7	6	5	4
L	L	I	J

(a)

0	1	2	3
5	0	0	0
4	5	6	7
J	I	L	L

(b)

0	1	2	3
0	0	0	5
4	5	6	7
L	L	I	J

(c)

- a) Original message on the Pentium
- b) The message after receipt on the SPARC
- c) The message after being inverted. The little numbers in boxes indicate the address of each byte

Parameter Specification and Stub Generation

- a)
- b)

A procedure

The corresponding message.

```
foobar( char x; float y; int z[5] )  
{  
  ....  
}
```

(a)

foobar's local variables	
	x
y	
5	
z[0]	
z[1]	
z[2]	
z[3]	
z[4]	

(b)

Doors

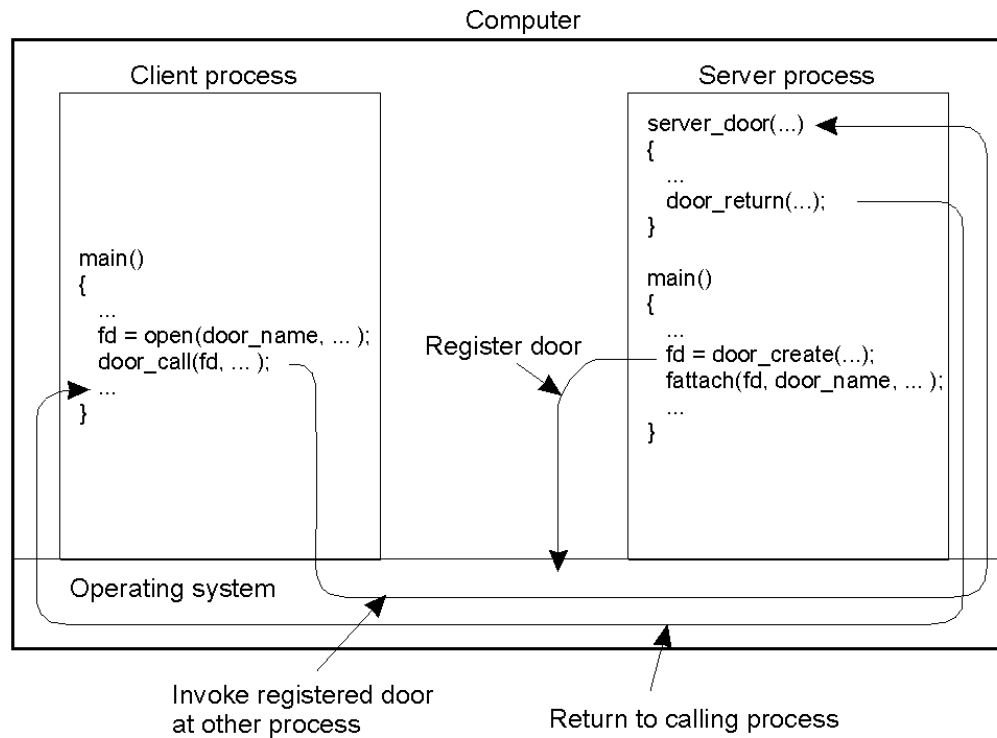

The principle of using doors as IPC mechanism.

Asynchronous RPC (1)

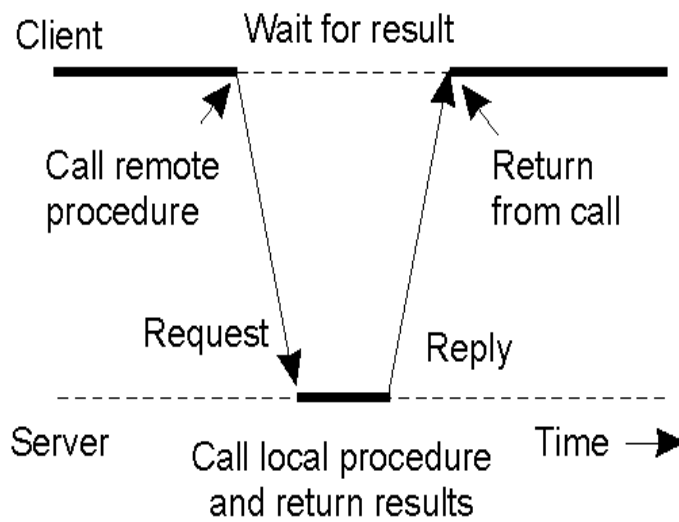

(a)

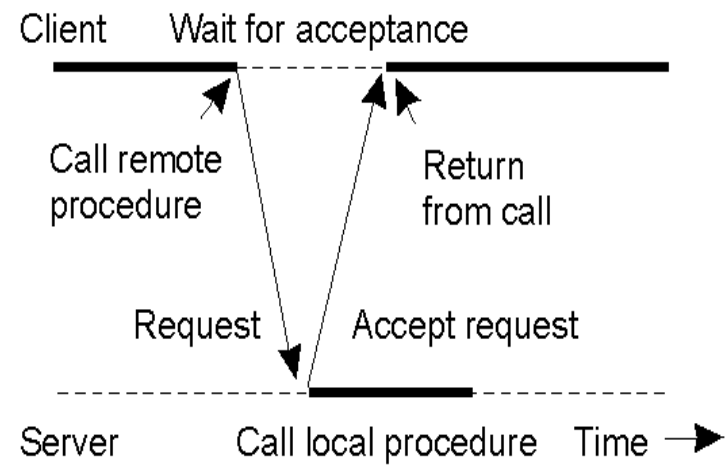

(b)

- a) The interconnection between client and server in a traditional RPC
- b) The interaction using asynchronous RPC

Asynchronous RPC (2)

A client and server interacting through two asynchronous RPCs

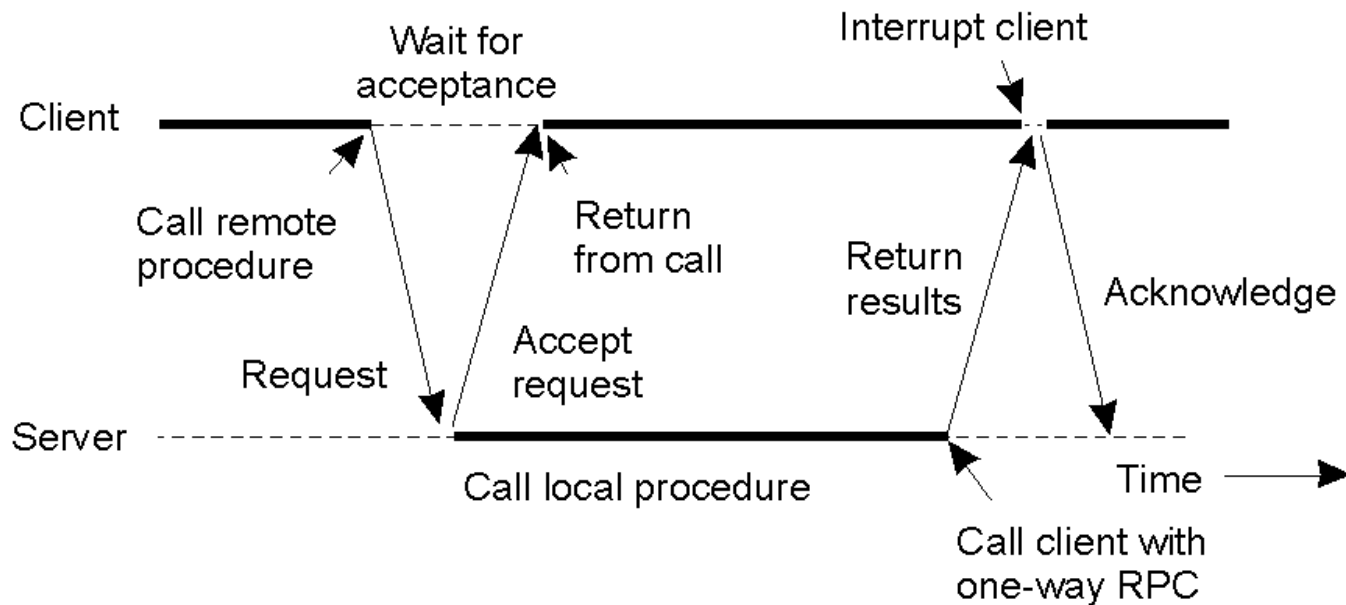

Writing a Client and a Server

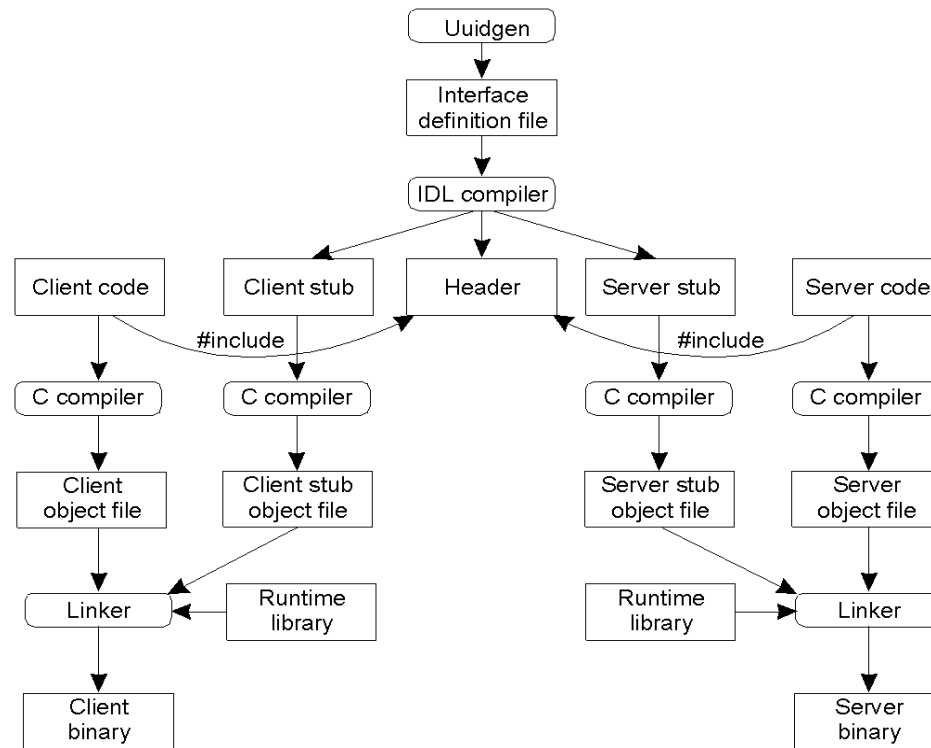

The steps in writing a client and a server in DCE RPC.

Binding a Client to a Server

Client-to-server binding in DCE.

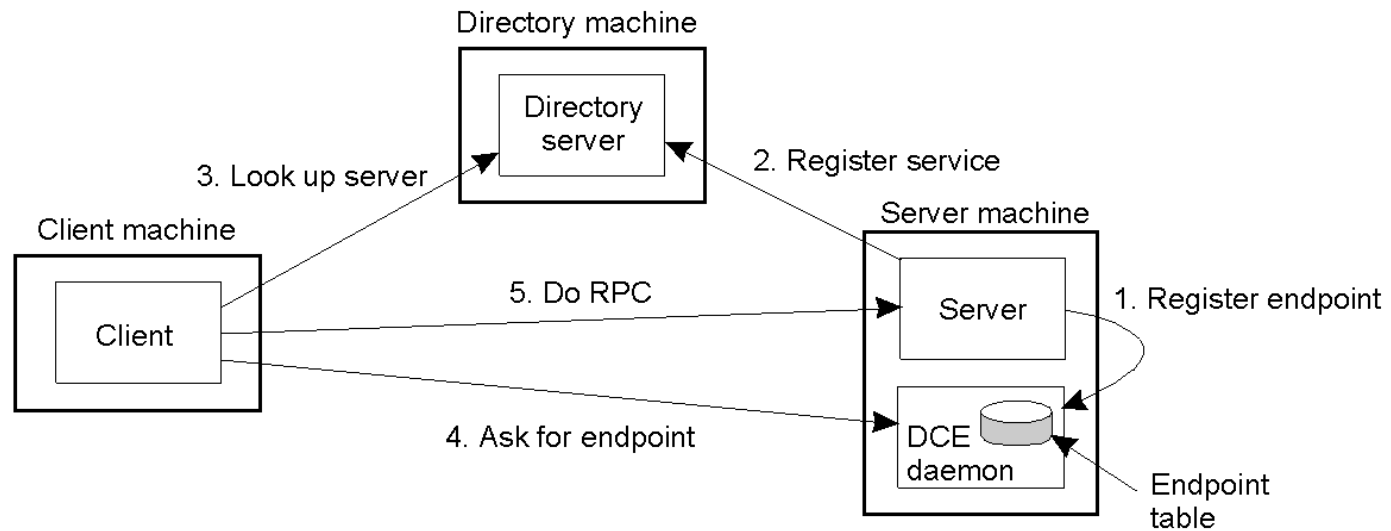

Distributed Objects

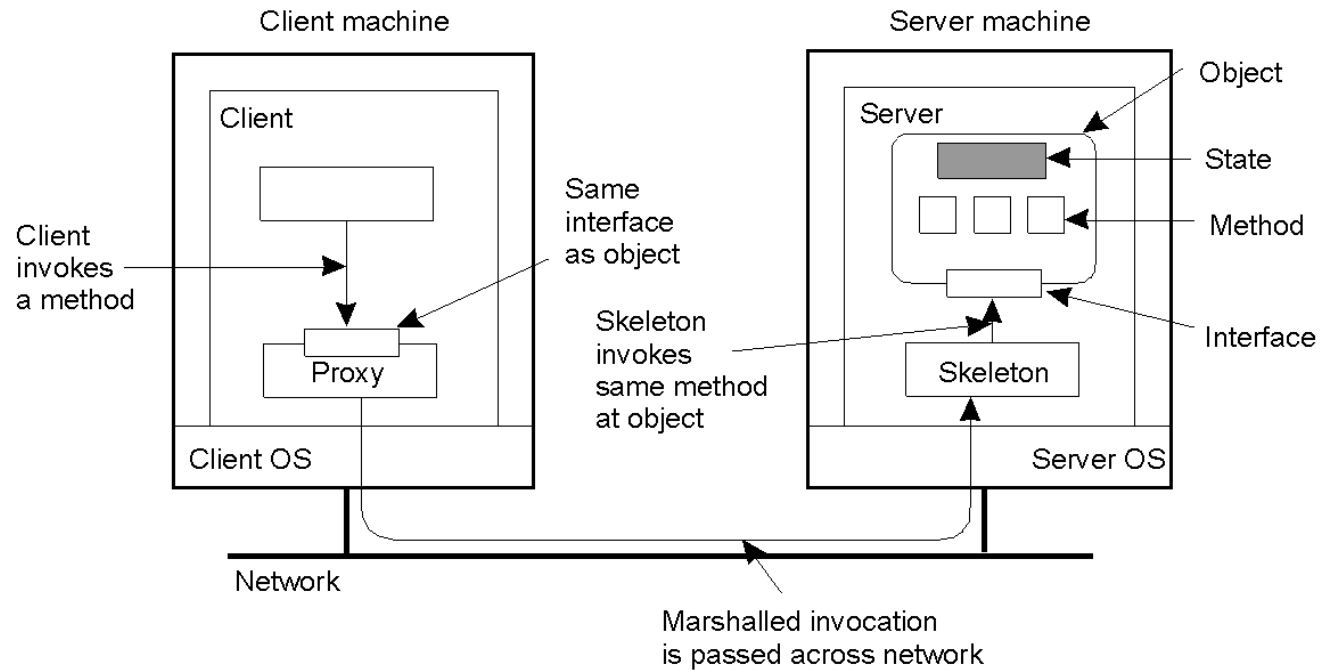

Common organization of a remote object with client-side proxy.

Binding a Client to an Object

```
Distr_object* obj_ref;  
obj_ref = ...;  
obj_ref-> do_something();
```

(a)

```
//Declare a systemwide object reference  
// Initialize the reference to a distributed object  
// Implicitly bind and invoke a method
```

```
Distr_object objPref;  
Local_object* obj_ptr;  
obj_ref = ...;  
obj_ptr = bind(obj_ref);  
obj_ptr -> do_something();
```

(b)

```
//Declare a systemwide object reference  
//Declare a pointer to local objects  
//Initialize the reference to a distributed object  
//Explicitly bind and obtain a pointer to the local proxy  
//Invoke a method on the local proxy
```

- a) (a) Example with implicit binding using only global references
- b) (b) Example with explicit binding using global and local references

Parameter Passing

The situation when passing an object by reference or by value.

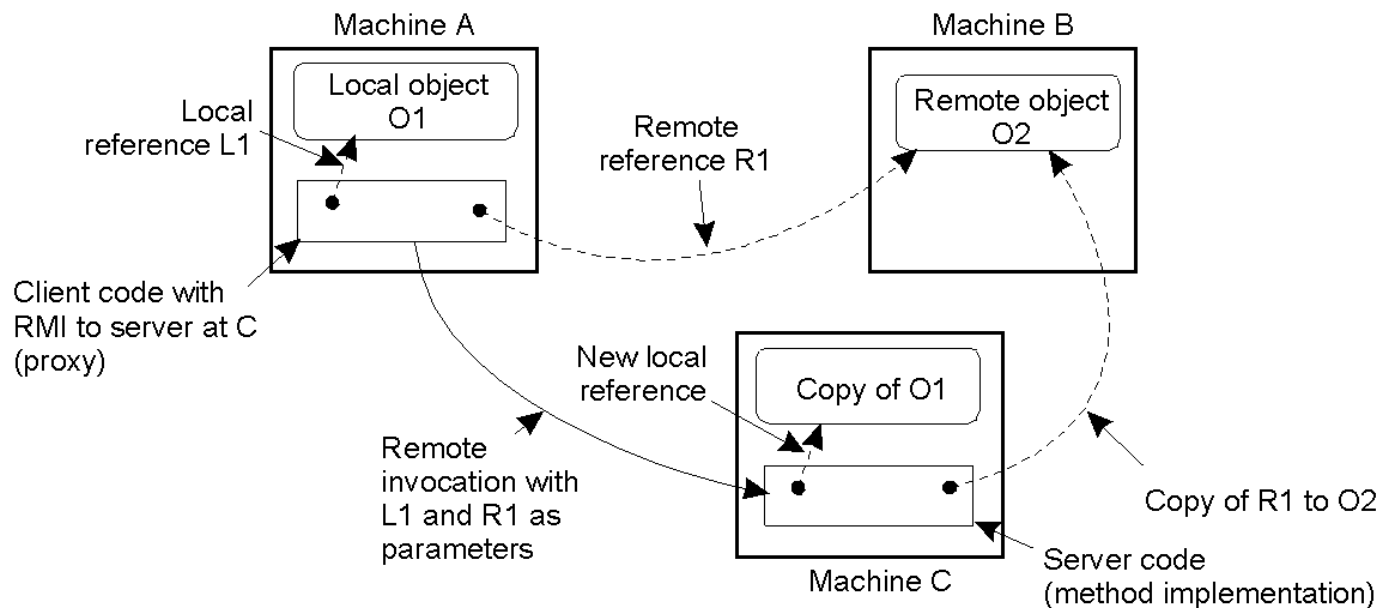

The DCE Distributed-Object Model

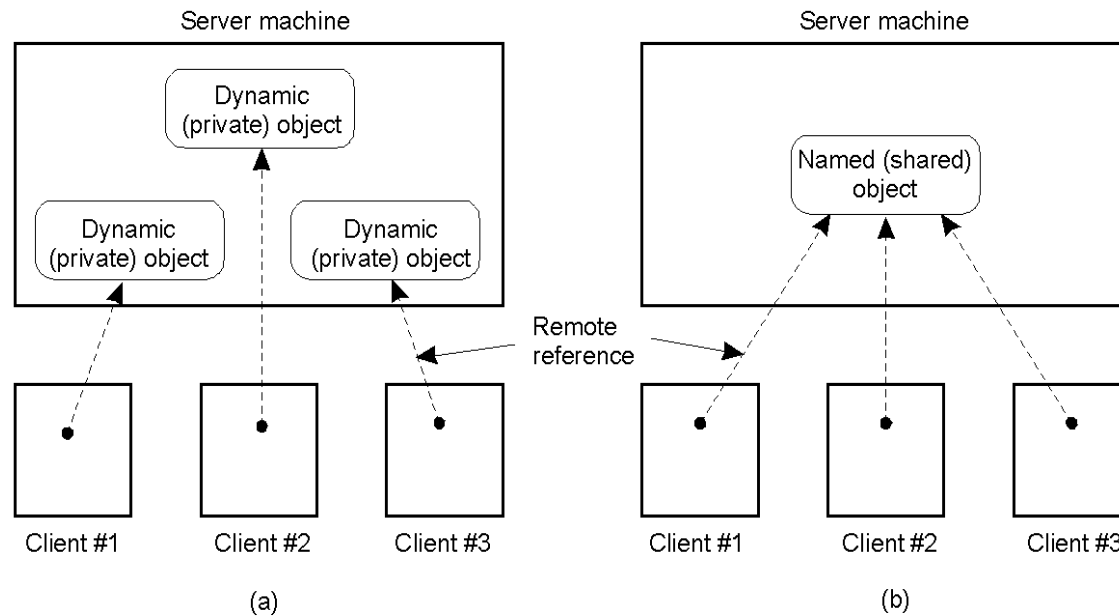

a)

Distributed dynamic objects in DCE.

b)

Distributed named objects

Persistence and Synchronicity in Communication (1)

General organization of a communication system in which hosts are connected through a network

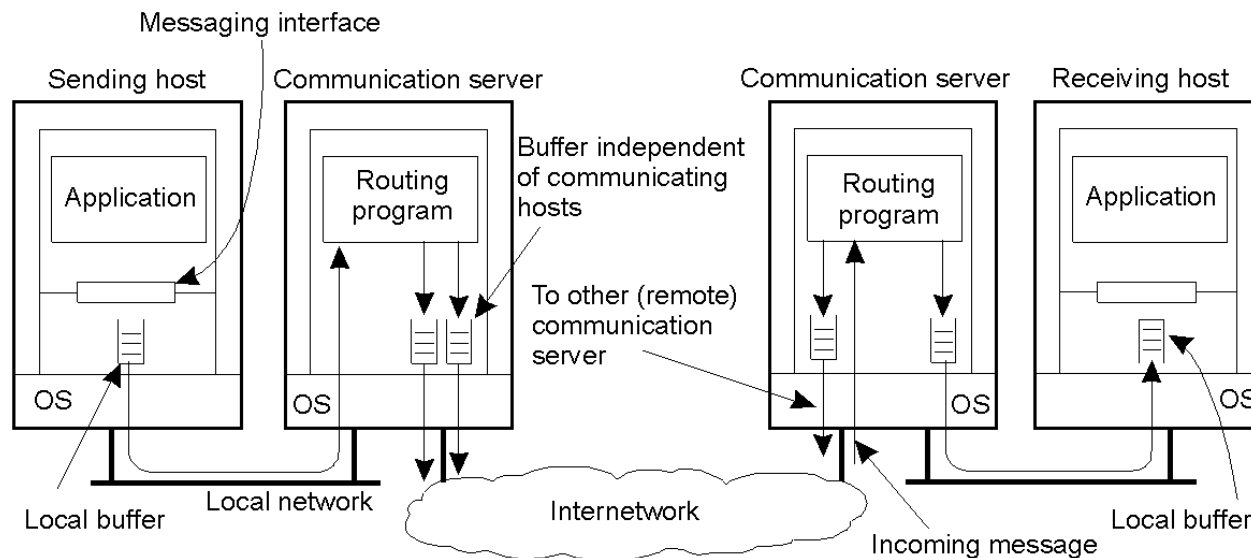

Persistence and Synchronicity in Communication (2)

Persistent communication of letters back in the days of the Pony Express.

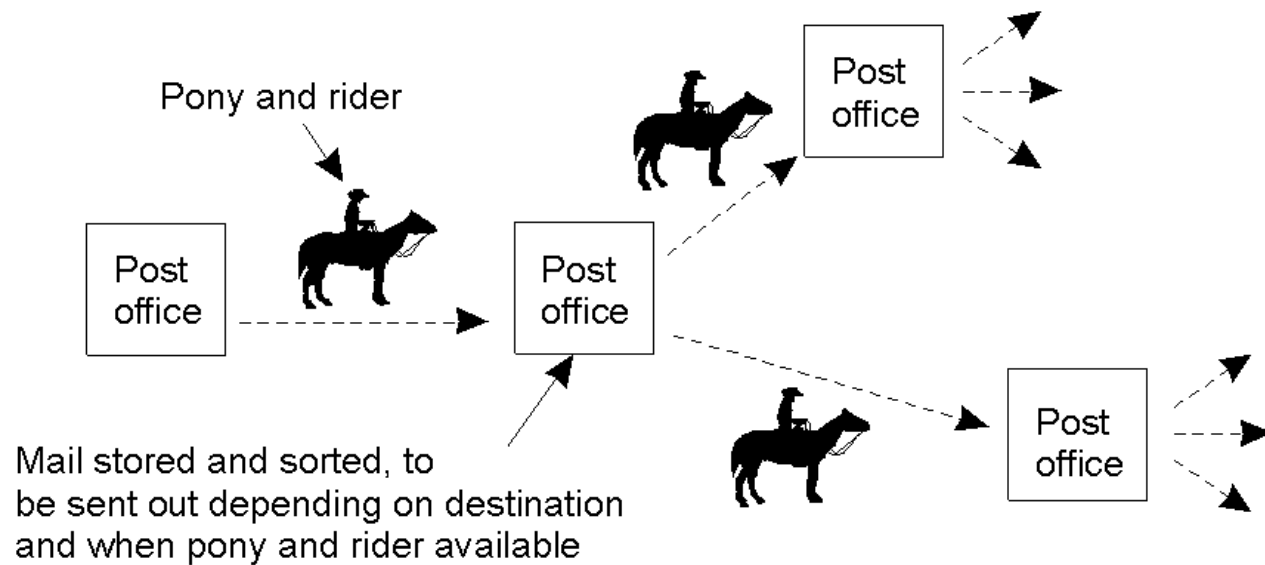

Persistence and Synchronicity in Communication (3)

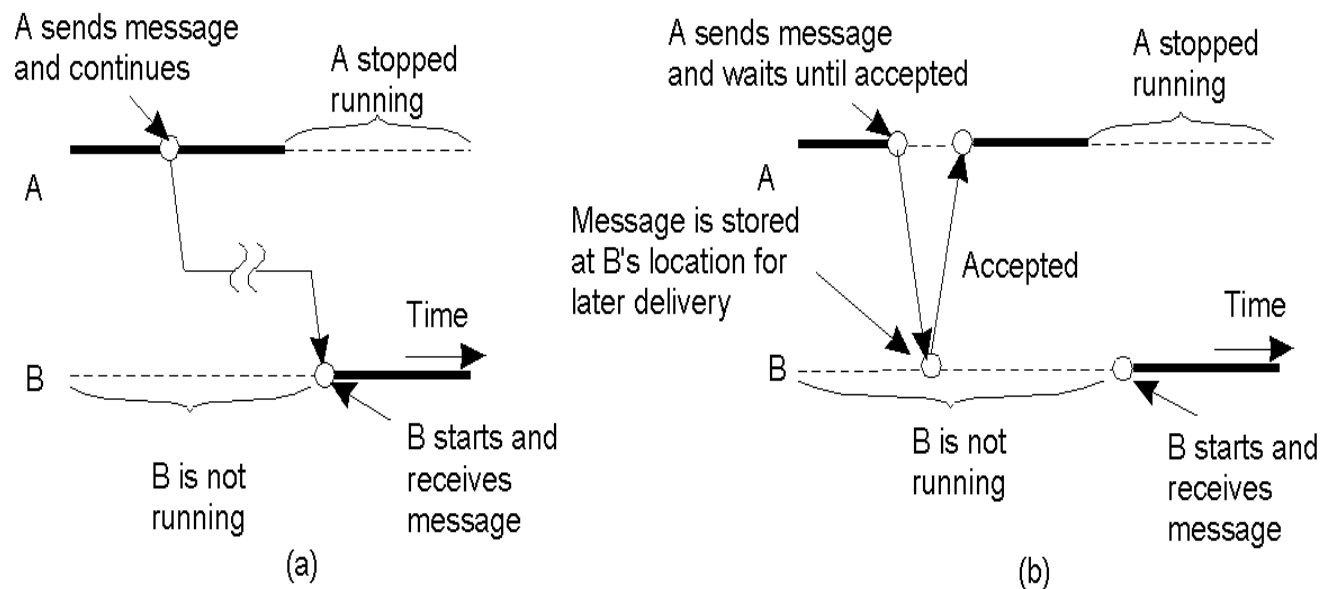

- a) Persistent asynchronous communication
- b) Persistent synchronous communication

Persistence and Synchronicity in Communication (4)

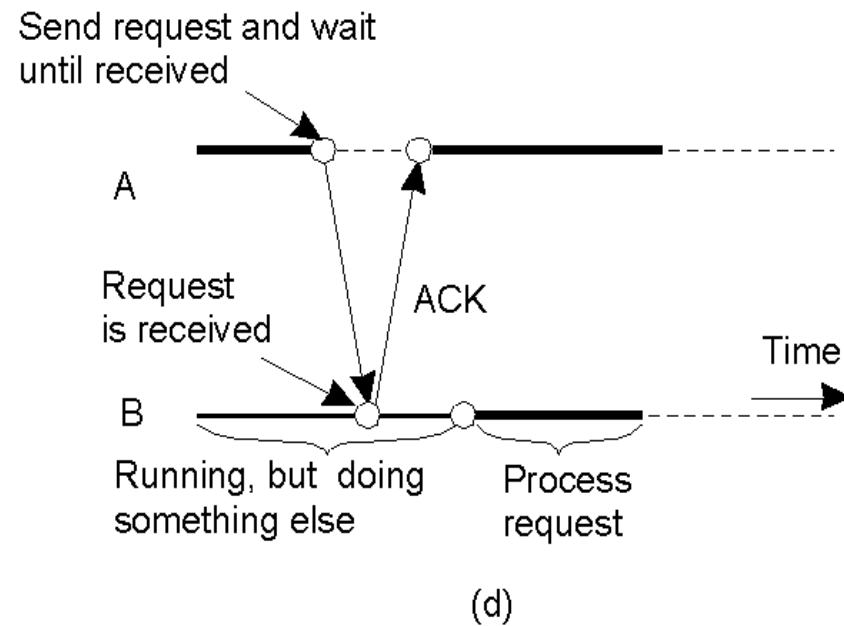
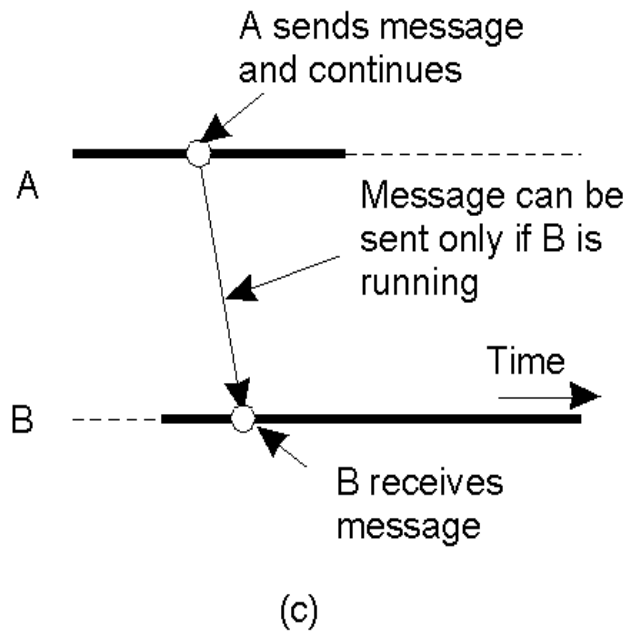

c)

Transient asynchronous communication

d)

Receipt-based transient synchronous communication

Persistence and Synchronicity in Communication (5)

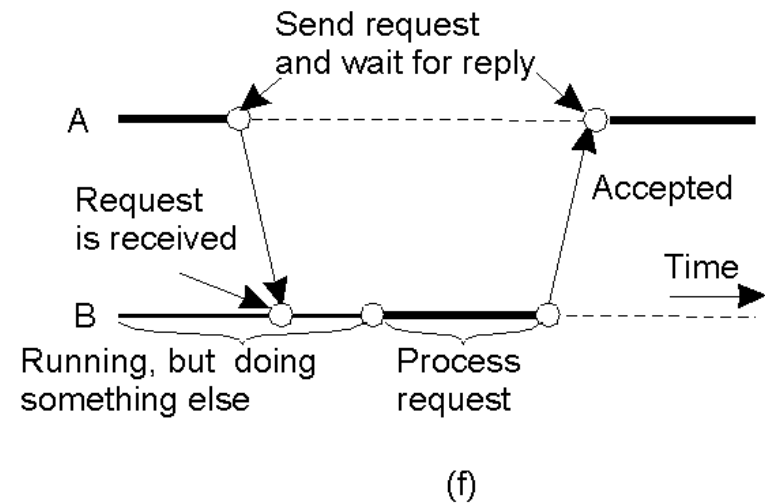
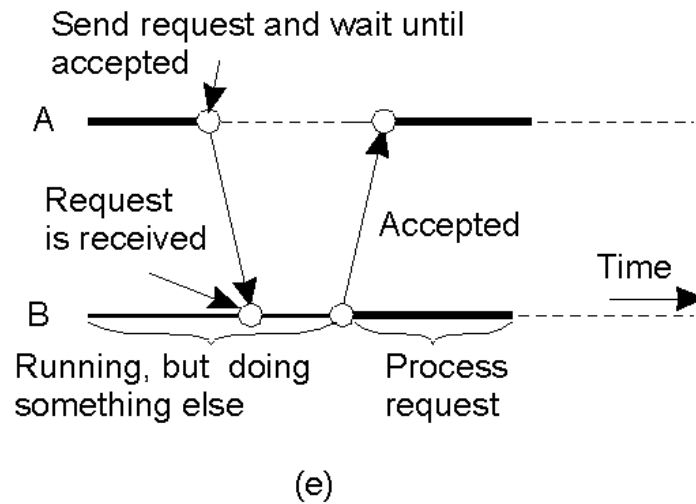

- e) Delivery-based transient synchronous communication at message delivery
- f) Response-based transient synchronous communication

Berkeley Sockets (1)

Socket primitives for TCP/IP.

Primitive	Meaning
Socket	Create a new communication endpoint
Bind	Attach a local address to a socket
Listen	Announce willingness to accept connections
Accept	Block caller until a connection request arrives
Connect	Actively attempt to establish a connection
Send	Send some data over the connection
Receive	Receive some data over the connection
Close	Release the connection

Berkeley Sockets (2)

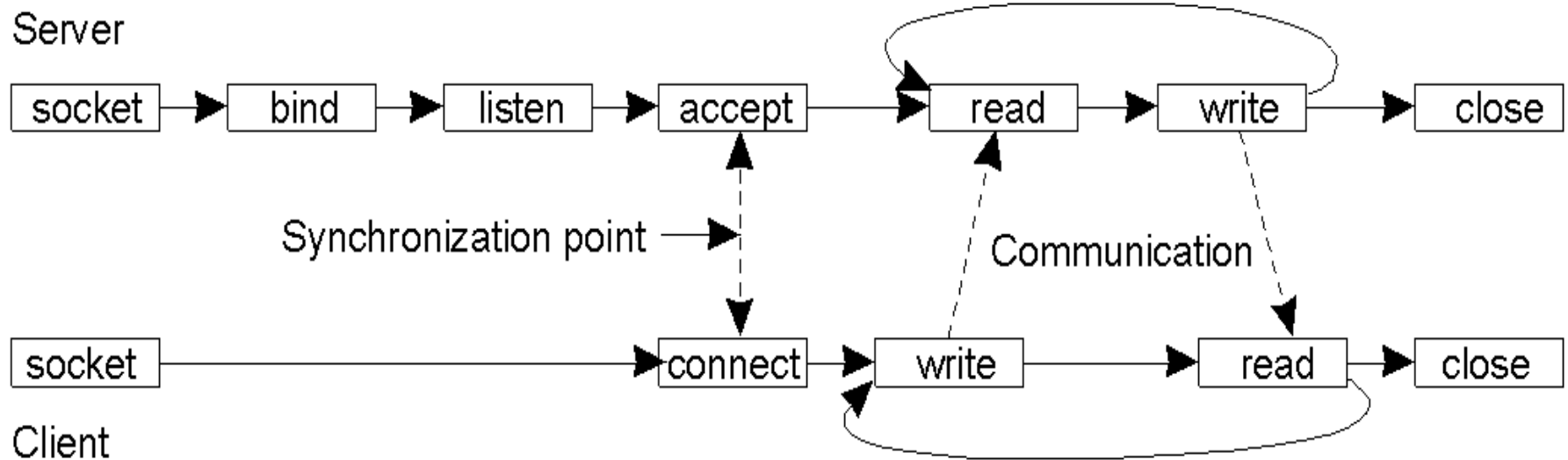

Connection-oriented communication pattern using sockets.

The Message-Passing Interface (MPI)

Some of the most intuitive message-passing primitives of MPI.

Primitive	Meaning
MPI_bsend	Append outgoing message to a local send buffer
MPI_send	Send a message and wait until copied to local or remote buffer
MPI_ssend	Send a message and wait until receipt starts
MPI_sendrecv	Send a message and wait for reply
MPI_isev	Pass reference to outgoing message, and continue
MPI_issend	Pass reference to outgoing message, and wait until receipt starts
MPI_recv	Receive a message; block if there are none
MPI_irecv	Check if there is an incoming message, but do not block

Message-Queuing Model (1)

Four combinations for loosely-coupled communications using queues.

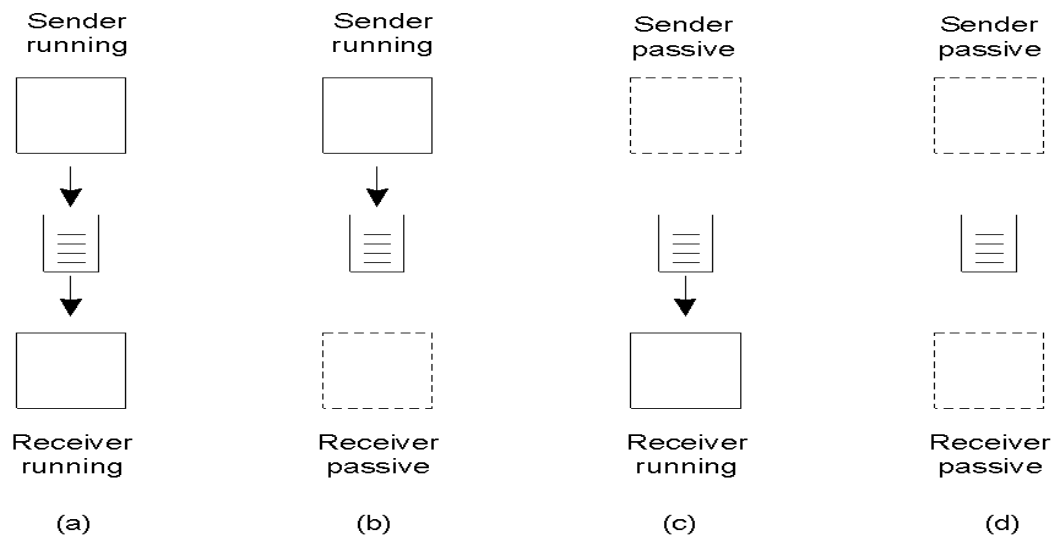

Message-Queuing Model (2)

Basic interface to a queue in a message-queuing system.

Primitive	Meaning
Put	Append a message to a specified queue
Get	Block until the specified queue is nonempty, and remove the first message
Poll	Check a specified queue for messages, and remove the first. Never block.
Notify	Install a handler to be called when a message is put into the specified queue.

General Architecture of a Message-Queuing System (1)

The relationship between queue-level addressing and network-level addressing.

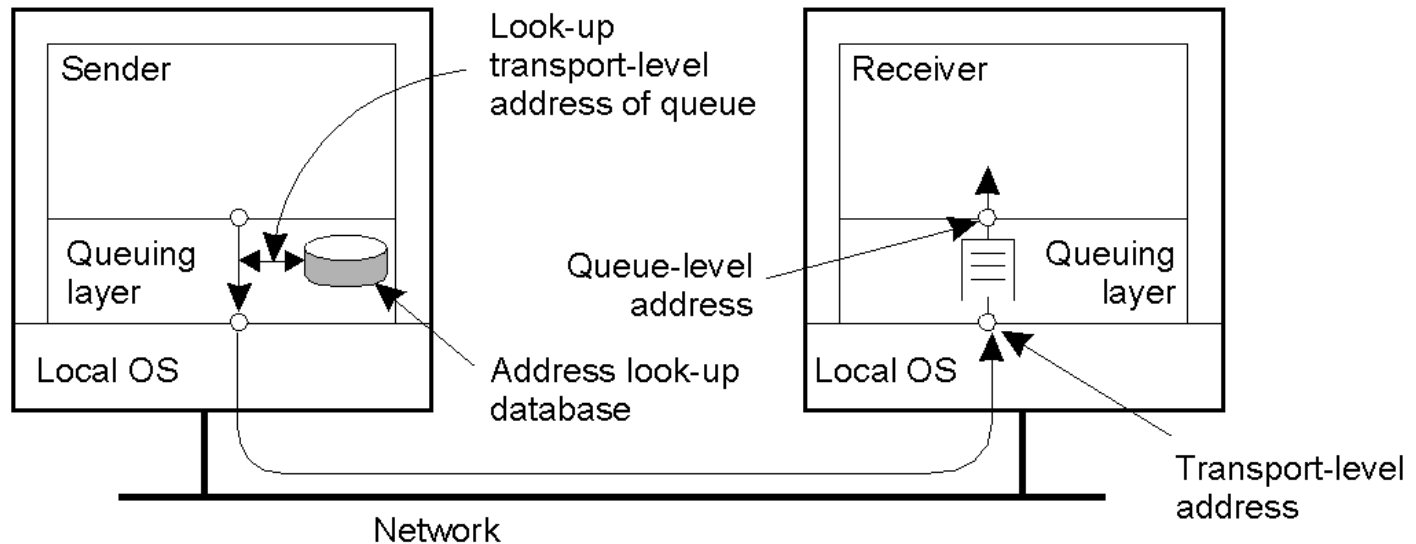

General Architecture of a Message-Queuing System (2)

The general organization of a message-queuing system with routers.

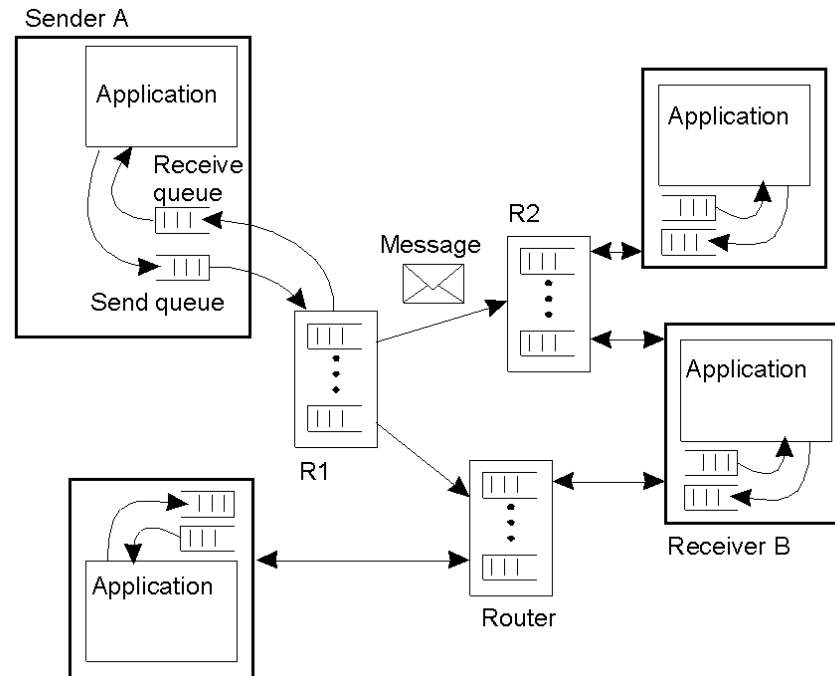

Message Brokers

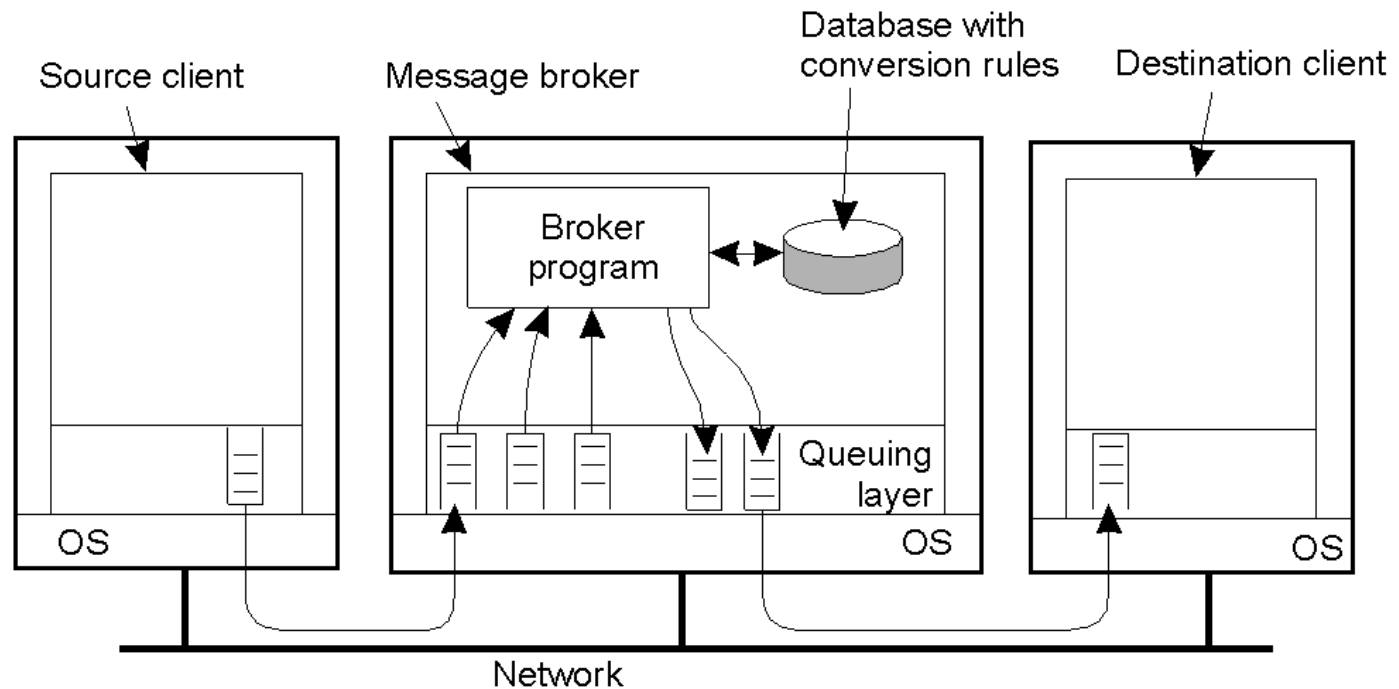

The general organization of a message broker in a message-queuing system.

Example: IBM MQSeries

General organization of IBM's MQSeries message-queuing system.

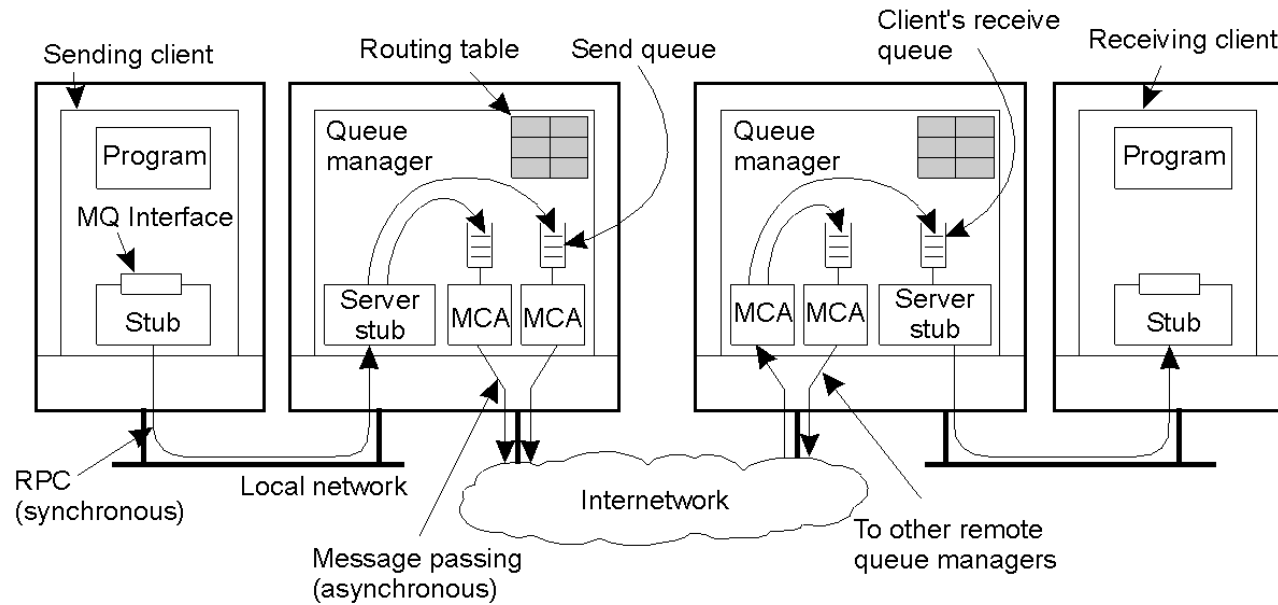

Channels

Some attributes associated with message channel

agents.

Attribute	Description
Transport type	Determines the transport protocol to be used
FIFO delivery	Indicates that messages are to be delivered in the order they are sent
Message length	Maximum length of a single message
Setup retry count	Specifies maximum number of retries to start up the remote MCA
Delivery retries	Maximum times MCA will try to put received message into queue

Message Transfer (1)

The general organization of an MQSeries queuing network using routing tables and aliases.

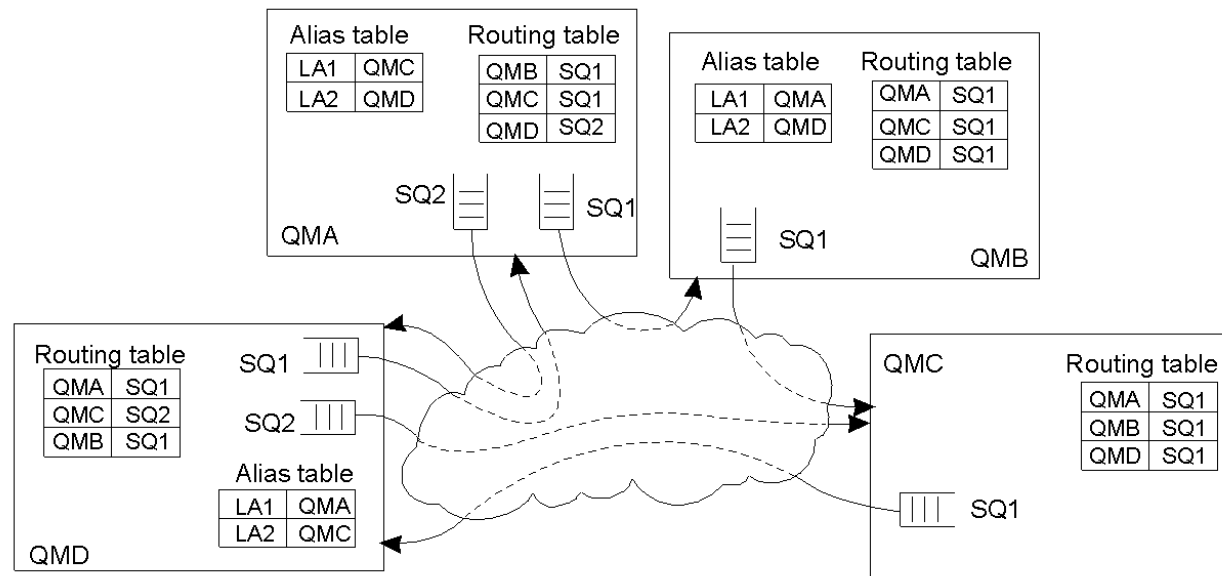

Message Transfer (2)

Primitive	Description
MQopen	Open a (possibly remote) queue
MQclose	Close a queue
MQput	Put a message into an opened queue
MQget	Get a message from a (local) queue

Primitives available in an IBM MQSeries MQI

Data Stream (1)

Setting up a stream between two processes across a network.

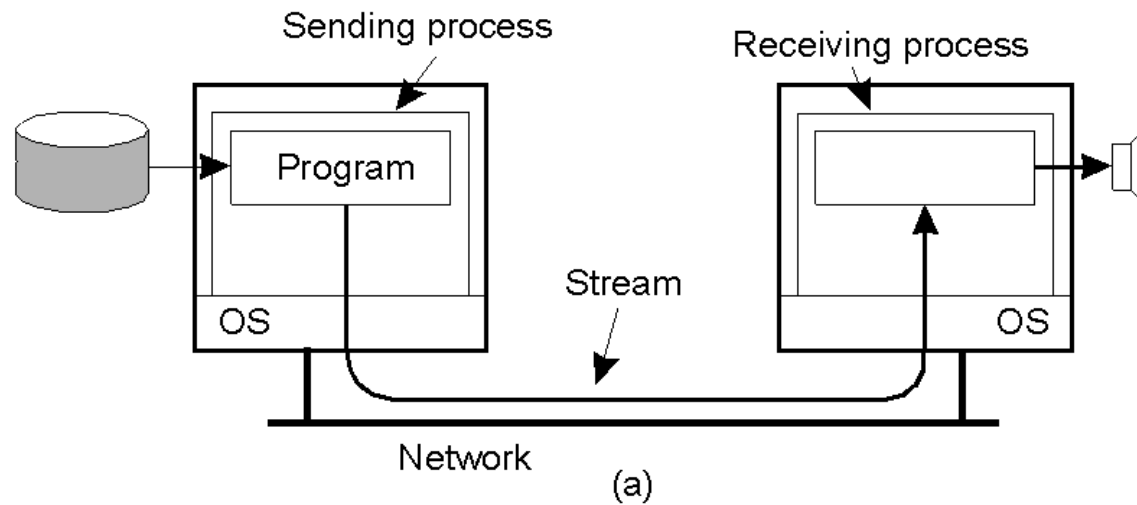

Data Stream (2)

Setting up a stream directly between two devices.

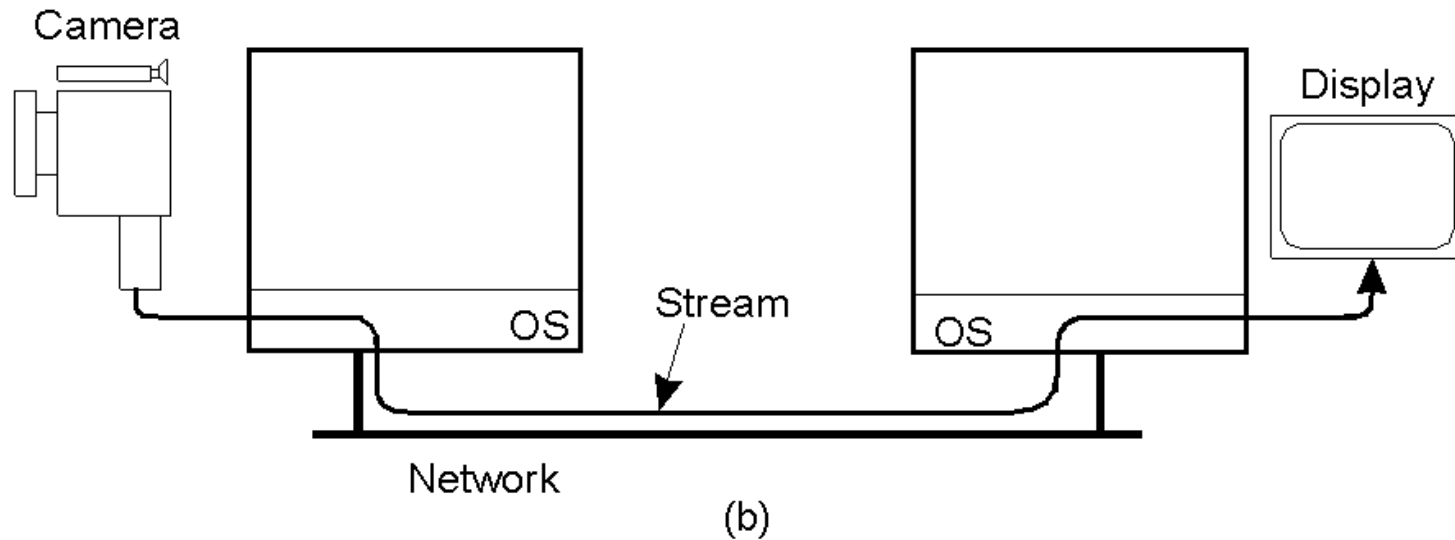

Data Stream (3)

An example of multicasting a stream to several receivers.

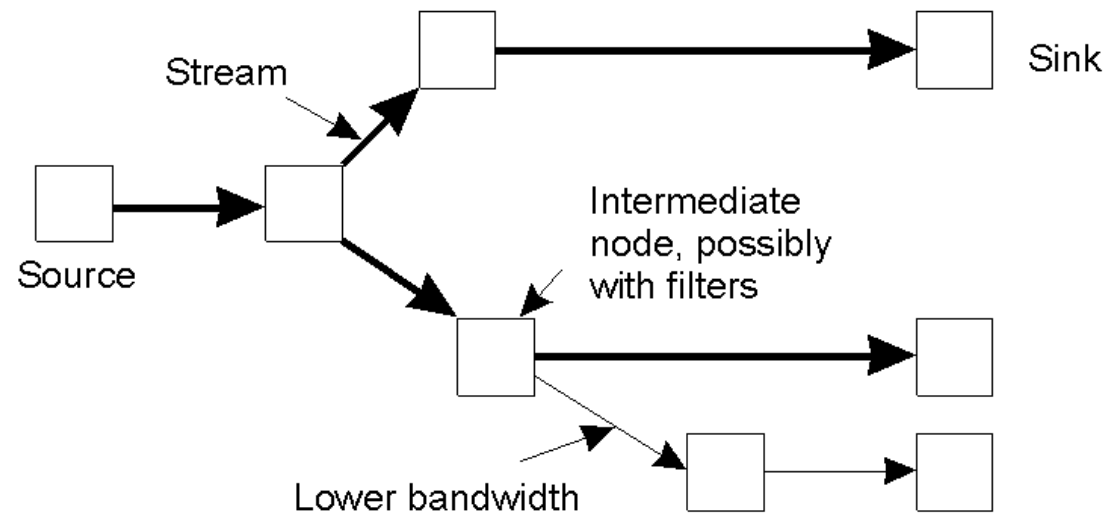

Specifying QoS (1)

Characteristics of the Input	Service Required
<ul style="list-style-type: none">• maximum data unit size (bytes)• Token bucket rate (bytes/sec)• Token bucket size (bytes)• Maximum transmission rate (bytes/sec)	<ul style="list-style-type: none">• Loss sensitivity (bytes)• Loss interval (μsec)• Burst loss sensitivity (data units)• Minimum delay noticed (μsec)• Maximum delay variation (μsec)• Quality of guarantee

A flow specification.

Specifying QoS (2)

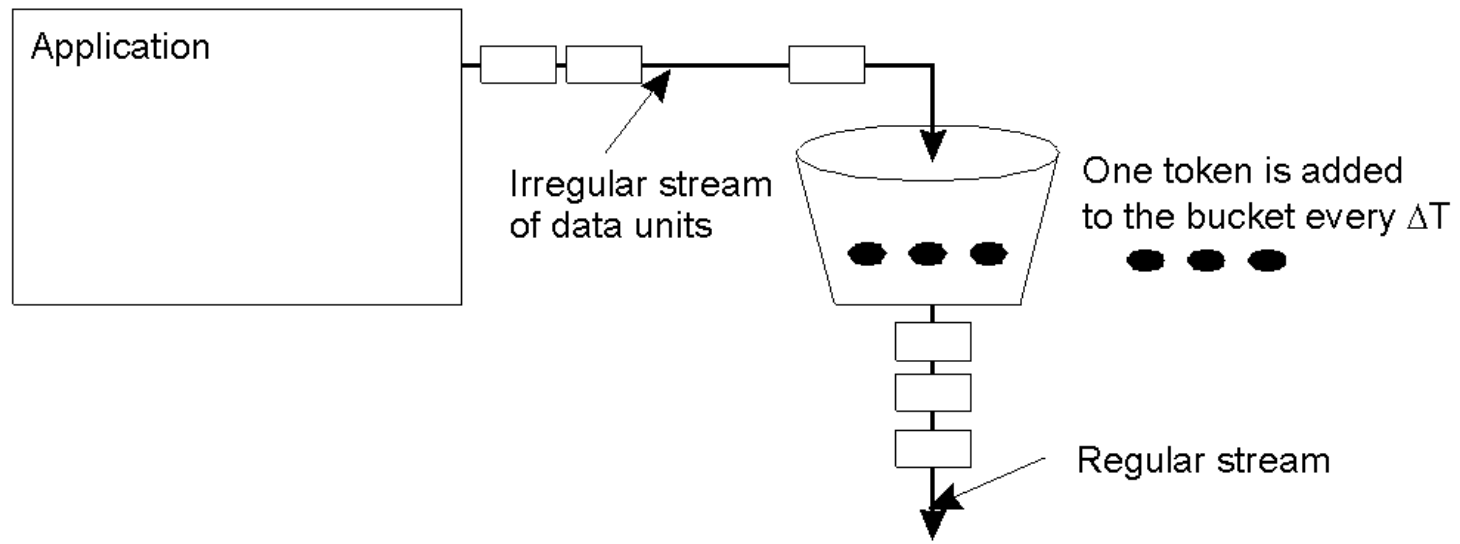

The principle of a token bucket algorithm.

Setting Up a Stream

The basic organization of RSVP for resource reservation in a distributed system.

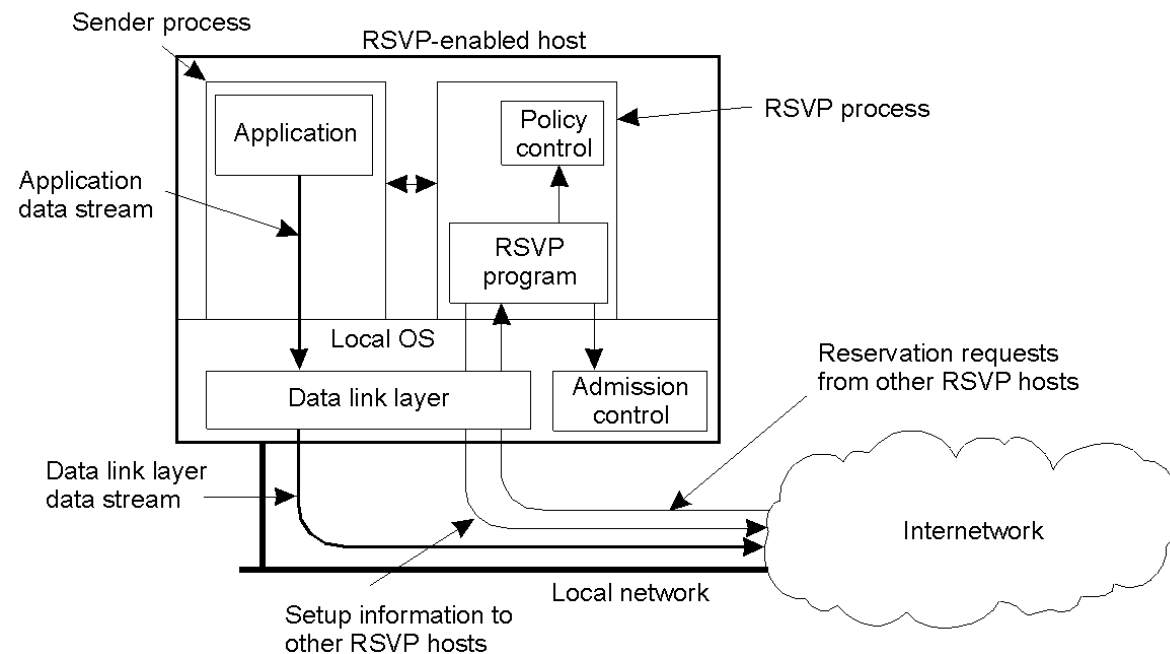

Synchronization Mechanisms

(1)

The principle of explicit synchronization on the level of data units.

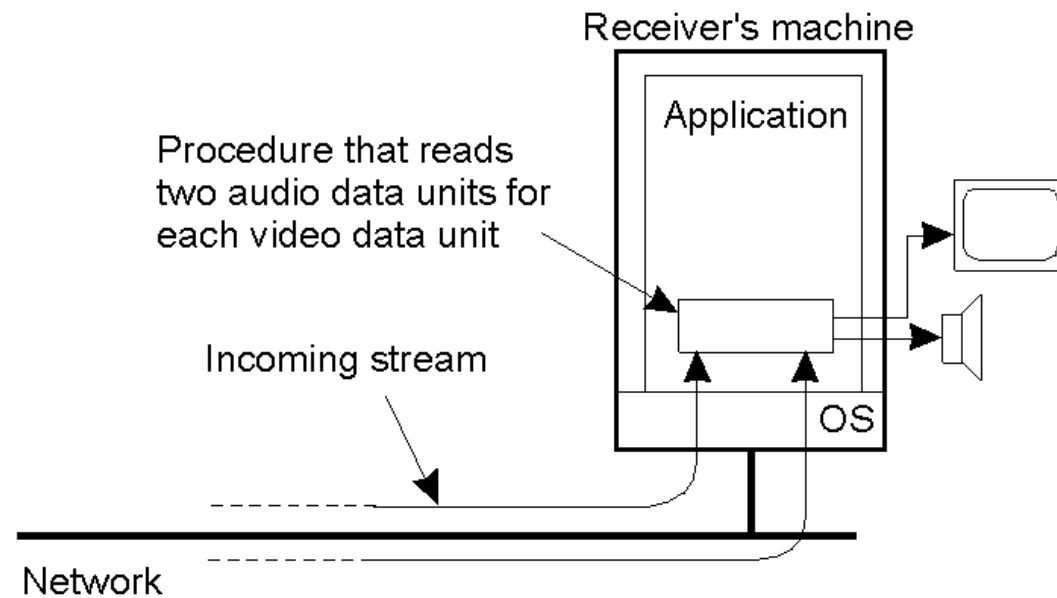

Synchronization Mechanisms

(2)

The principle of synchronization as supported by high-level interfaces.

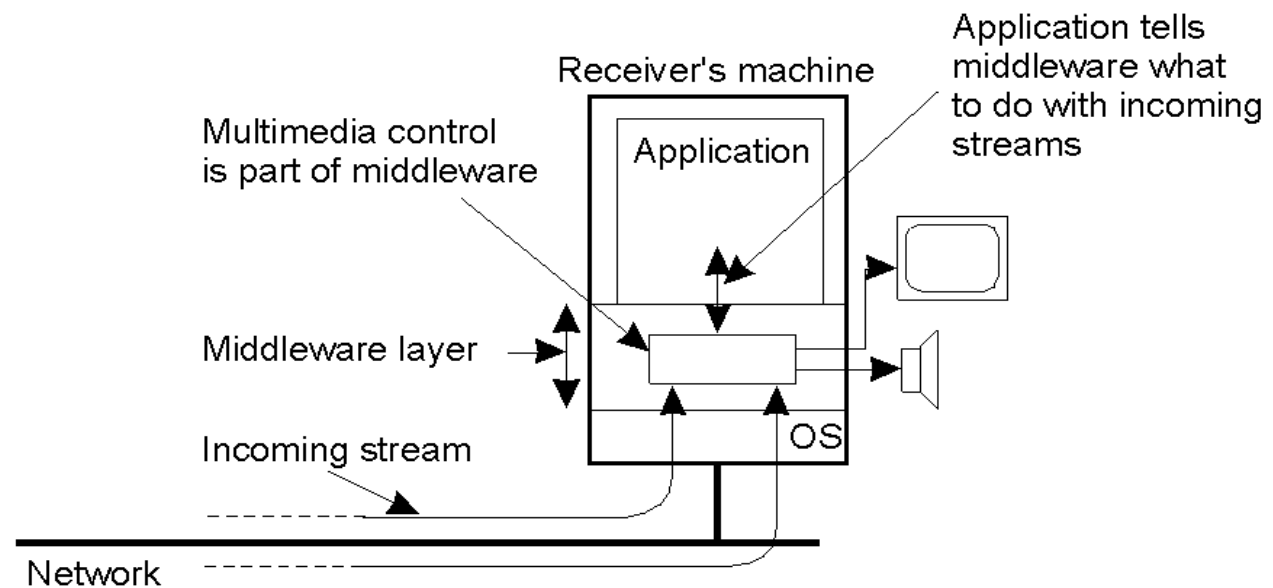



Application

- Communication between systems on large scale.
- Able to large number of systems though connecting different layer.
-



Scope of research

- AgentOS
- Web OS